

C141-E258-03EN

MHW2060AC, MHW2040AC

DISK DRIVES

PRODUCT MANUAL

FOR SAFE OPERATION

Handling of This Manual

This manual contains important information for using this product. Read thoroughly before using the product. Use this product only after thoroughly reading and understanding especially the section "Important Alert Items" in this manual. Keep this manual handy, and keep it carefully.

FUJITSU makes every effort to prevent users and bystanders from being injured or from suffering damage to their property. Use the product according to this manual.

IMPORTANT NOTE TO USERS

READ THE ENTIRE MANUAL CAREFULLY BEFORE USING THIS PRODUCT. INCORRECT USE OF THE PRODUCT MAY RESULT IN INJURY OR DAMAGE TO USERS, BYSTANDERS OR PROPERTY.

While FUJITSU has sought to ensure the accuracy of all information in this manual, FUJITSU assumes no liability to any party for any damage caused by any error or omission contained in this manual, its updates or supplements, whether such errors or omissions result from negligence, accident, or any other cause. In addition, FUJITSU assumes no liability with respect to the application or use of any product or system in accordance with the descriptions or instructions contained herein; including any liability for incidental or consequential damages arising therefrom. FUJITSU DISCLAIMS ALL WARRANTIES REGARDING THE INFORMATION CONTAINED HEREIN, WHETHER EXPRESSED, IMPLIED, OR STATUTORY.

FUJITSU reserves the right to make changes to any products described herein without further notice and without obligation.

This product is designed and manufactured for use in standard applications such as office work, personal devices and household appliances. This product is not intended for special uses (atomic controls, aeronautic or space systems, mass transport vehicle operating controls, medical devices for life support, or weapons firing controls) where particularly high reliability requirements exist, where the pertinent levels of safety are not guaranteed, or where a failure or operational error could threaten a life or cause a physical injury (hereafter referred to as "mission-critical" use). Customers considering the use of these products for mission-critical applications must have safety-assurance measures in place beforehand. Moreover, they are requested to consult our sales representative before embarking on such specialized use.

The contents of this manual may be revised without prior notice.

The contents of this manual shall not be disclosed in any way or reproduced in any media without the express written permission of Fujitsu Limited.

Revision History

(1/1)

Edition	Date	Revised section (*1) (Added/Deleted/Altered)	Details
01	2007-02-28	—	—
02	2007-06-15	Entire manual (added)	Addition of description for CA06821-B902.
03	2007-08-24	Entire manual (added)	Addition of description for MHW2060AC

1 Section(s) with asterisk () refer to the previous edition when those were deleted.

This page is intentionally left blank.

Preface

This manual describes MHW2060AC, and MHW2040AC models of the MHW Series, 2.5-inch hard disk drives. This drive has a built-in controller that is compatible with the ATA interface.

This manual describes the specifications and functions of the drive and explains in detail how to incorporate the drive into user systems. This manual assumes that the reader has a basic knowledge of hard disk drive and their implementations in computer systems.

This manual consists of seven chapters and sections explaining the special terminology and abbreviations used in this manual:

Overview of Manual

CHAPTER 1 Device Overview

This chapter gives an overview of the disk drive and describes their features.

CHAPTER 2 Device Configuration

This chapter describes the internal configurations of the disk drive and the configuration of the systems in which they operate.

CHAPTER 3 Installation Conditions

This chapter describes the external dimensions, installation conditions, and switch settings of the disk drive.

CHAPTER 4 Theory of Device Operation

This chapter describes the operation theory of the disk drive.

CHAPTER 5 Interface

This chapter describes the interface specifications of the disk drive.

CHAPTER 6 Operations

This chapter describes the operations of the disk drive.

Glossary

The glossary describes the technical terms that need to be understood to read this manual.

Acronyms and Abbreviations

This section gives the meanings of the definitions used in this manual.

Conventions for Alert Messages

This manual uses the following conventions to show the alert messages. An alert message consists of an alert signal and alert statements. The alert signal consists of an alert symbol and a signal word or just a signal word.

The following are the alert signals and their meanings:



This indicates a hazardous situation *could* result in *minor* or *moderate personal injury* if the user does not perform the procedure correctly. This alert signal also indicates that damages to the product or other property *may* occur if the user does not perform the procedure correctly.

IMPORTANT

This indicates information that could help the user use the product more efficiently.

In the text, the alert signal is centered, followed below by the indented message. A wider line space precedes and follows the alert message to show where the alert message begins and ends. The following is an example:

(Example)



Data corruption: Avoid mounting the disk drive near strong magnetic sources such as loud speakers. Ensure that the disk drive is not affected by external magnetic fields.

The main alert messages in the text are also listed in the “Important Alert Items.”

Operating Environment

This product is designed considering its application in car navigation systems.

Conventions

An MHW series device is sometimes simply referred to as a "hard disk drive," "HDD," "drive," or "device" in this document.

Decimal numbers are represented normally.

Hexadecimal numbers are represented as shown in the following examples: X'17B9', 17B9h, 17B9_H, or 17B9H.

Binary numbers are represented as shown in the following examples: 010 or 010b.

IMPORTANT

Representation of the data storage capacity in this manual

One gigabyte (GB) = one billion bytes; accessible capacity will be less and actual capacity depends on the operating environment and formatting.

Attention

Please forward any comments you may have regarding this manual.

To make this manual easier for users to understand, opinions from readers are needed. Please write your opinions or requests on the Comment at the back of this manual and forward it to the address described in the sheet.

Liability Exception

“Disk drive defects” refers to defects that involve adjustment, repair, or replacement.

Fujitsu is not liable for any other disk drive defects, such as those caused by user misoperation or mishandling, inappropriate operating environments, defects in the power supply or cable, problems of the host system, or other causes outside the disk drive.

Compliance with Administration on the Control of Pollution Caused by Electronic Information Products of the People's Republic of China

电子信息产品污染控制管理办法 (第 39 号)



这标记是按照 2006 年 2 月 28 日公布的[电子信息产品污染控制管理办法]以及 SJ/T11364-2006[电子信息产品污染控制标识要求]在中国销售的电子信息产品的环保使用期限。如遵守关于这产品的安全或使用上的注意，在这期限内(从生产日期起算)不会因产品中的有害物质漏到外部、或发生突然变异，而引起环境污染和对人体或财产的重大影响。

产品中有毒有害物质或元素的名称及含量

部件名称	有毒有害物质或元素					
	铅 (Pb)	汞 (Hg)	镉 (Cd)	六价铬 (Cr(VI))	多溴联苯 (PBB)	多溴二苯醚 (PBDE)
HDD(硬盘驱动器)	×	○	○	○	○	○
○：表示该有毒有害物质在该部件所有均质材料中的含量均在 SJ/T 11363-2006 规定的限量要求以下。 ×：表示该有毒有害物质至少在该部件的某一均质材料中的含量超出 SJ/T 11363-2006 规定的限量要求。						

This product is shipped as a component to manufacture the final products. Therefore, the packaging material code provided in GB18455-2001 is not marked on any packaging part of this product.

This page is intentionally left blank.

Important Alert Items

Important Alert Messages

The important alert messages in this manual are as follows:



A hazardous situation *could* result in *minor* or *moderate personal injury* if the user does not perform the procedure correctly. Also, damage to the product or other property, *may* occur if the user does not perform the procedure correctly.

Task	Alert message	Page
Normal Operation	<p>Data corruption: Avoid mounting the disk near strong magnetic sources such as loud speakers. Ensure that the disk drive is not affected by external magnetic fields.</p> <p>Damage: Do not press the cover of the disk drive. Pressing it too hard, the cover and the spindle motor contact, which may cause damage to the disk drive.</p> <p>Static: When handling the device, disconnect the body ground (500 kΩ or greater). Do not touch the printed circuit board, but hold it by the edges.</p>	3-6
	<p>Damage: Interface cable connection</p> <p>Take note of the following precaution about plugging an interface cable (socket) into the interface connector of the disk drive and plugging the connector into a host receptacle:</p> <ul style="list-style-type: none">– When plugging together the disk drive interface connector and the host receptacle or interface cable connector (socket), do not apply more than 10 kgf of force in the connection direction once they are snugly and securely in position.	3-9

This page is intentionally left blank.

Manual Organization

MHW2060AC, MHW2040AC

DISK DRIVES
PRODUCT MANUAL
(C141-E258)

<This manual>

- Device Overview
- Device Configuration
- Installation Conditions
- Theory of Device Operation
- Interface
- Operations

MHW2060AC, MHW2040AC

DISK DRIVES
MAINTENANCE MANUAL
(C141-F086)

- Maintenance and Diagnosis
- Removal and Replacement Procedure

This page is intentionally left blank.

Contents

CHAPTER 1	Device Overview	1-1
1.1	Features	1-2
1.1.1	Functions and performance	1-2
1.1.2	Adaptability	1-2
1.1.3	Interface	1-3
1.2	Device Specifications	1-4
1.2.1	Specifications summary	1-4
1.2.2	Model and product number	1-6
1.3	Power Requirements	1-7
1.4	Environmental Specifications	1-10
1.5	Acoustic Noise	1-11
1.6	Shock and Vibration	1-11
1.7	Reliability	1-12
1.8	Error Rate	1-13
1.9	Media Defects	1-13
1.10	Load/Unload Function	1-13
1.10.1	Recommended power-off sequence	1-14
1.11	Advanced Power Management (APM)	1-14
CHAPTER 2	Device Configuration	2-1
2.1	Device Configuration	2-2
2.2	System Configuration	2-3
2.2.1	ATA interface	2-3
2.2.2	1 drive connection	2-3
2.2.3	2 drives connection	2-4

CHAPTER 3	Installation Conditions	3-1
3.1	Dimensions	3-2
3.2	Mounting	3-3
3.3	Cable Connections.....	3-8
3.3.1	Device connector	3-8
3.3.2	Cable connector specifications	3-9
3.3.3	Device connection	3-9
3.3.4	Power supply connector (CN1)	3-10
3.4	Jumper Settings.....	3-10
3.4.1	Location of setting jumpers	3-10
3.4.2	Factory default setting	3-11
3.4.3	Master drive-slave drive setting.....	3-11
3.4.4	CSEL setting.....	3-12
3.4.5	Power up in standby setting.....	3-13
CHAPTER 4	Theory of Device Operation.....	4-1
4.1	Outline	4-2
4.2	Subassemblies.....	4-2
4.2.1	Disk.....	4-2
4.2.2	Spindle.....	4-2
4.2.3	Actuator	4-2
4.2.4	Air filter	4-3
4.3	Circuit Configuration.....	4-3
4.4	Power-on Sequence	4-6
4.5	Self-calibration	4-7
4.5.1	Self-calibration contents	4-7
4.5.2	Execution timing of self-calibration	4-8
4.5.3	Command processing during self-calibration.....	4-8
4.6	Read/write Circuit.....	4-9
4.6.1	Read/write preamplifier (PreAMP)	4-9

4.6.2	Write circuit.....	4-9
4.6.3	Read circuit.....	4-10
4.6.4	Digital PLL circuit.....	4-11
4.7	Servo Control	4-12
4.7.1	Servo control circuit	4-12
4.7.2	Data-surface servo format	4-15
4.7.3	Servo frame format.....	4-17
4.7.4	Actuator motor control	4-18
4.7.5	Spindle motor control.....	4-19
CHAPTER 5	Interface	5-1
5.1	Physical Interface	5-2
5.1.1	Interface signals.....	5-2
5.1.2	Signal assignment on the connector	5-3
5.2	Logical Interface.....	5-6
5.2.1	I/O registers	5-7
5.2.2	Command block registers	5-8
5.2.3	Control block registers	5-13
5.3	Host Commands	5-14
5.3.1	Command code and parameters.....	5-14
5.3.2	Command descriptions	5-18
	(1) RECALIBRATE (X'10' to X'1F').....	5-20
	(2) READ SECTOR(S) (X'20' or X'21')	5-21
	(3) WRITE SECTOR(S) (X'30' or X'31').....	5-23
	(4) WRITE VERIFY (X'3C').....	5-25
	(5) READ VERIFY SECTOR(S) (X'40' or X'41').....	5-26
	(6) SEEK (X'70' to X'7F')	5-27
	(7) EXECUTE DEVICE DIAGNOSTIC (X'90')	5-28
	(8) INITIALIZE DEVICE PARAMETERS (X'91')	5-30
	(9) DOWNLOAD MICROCODE (X'92').....	5-31
	(10) STANDBY IMMEDIATE (X'94' or X'E0')	5-33
	(11) IDLE IMMEDIATE (X'95' or X'E1') / UNLOAD IMMEDIATE (X'95' or X'E1').....	5-34
	(12) STANDBY (X'96' or X'E2')	5-36

(13) IDLE (X'97' or X'E3')	5-37
(14) CHECK POWER MODE (X'98' or X'E5')	5-39
(15) SLEEP (X'99' or X'E6')	5-40
(16) SMART (X'B0)	5-41
(17) DEVICE CONFIGURATION (X'B1')	5-58
(18) READ MULTIPLE (X'C4')	5-63
(19) WRITE MULTIPLE (X'C5')	5-65
(20) SET MULTIPLE MODE (X'C6')	5-67
(21) READ DMA (X'C8' or X'C9')	5-69
(22) WRITE DMA (X'CA' or X'CB')	5-71
(23) READ BUFFER (X'E4')	5-73
(24) FLUSH CACHE (X'E7')	5-74
(25) WRITE BUFFER (X'E8')	5-75
(26) IDENTIFY DEVICE (X'EC')	5-76
(27) IDENTIFY DEVICE DMA (X'EE')	5-77
(28) SET FEATURES (X'EF')	5-89
(29) SECURITY SET PASSWORD (X'F1')	5-93
(30) SECURITY UNLOCK(X'F2')	5-95
(31) SECURITY ERASE PREPARE (X'F3')	5-97
(32) SECURITY ERASE UNIT (X'F4')	5-98
(33) SECURITY FREEZE LOCK (X'F5')	5-99
(34) SECURITY DISABLE PASSWORD (X'F6')	5-101
(35) READ NATIVE MAX ADDRESS (X'F8')	5-103
(36) SET MAX (X'F9')	5-104
(37) READ SECTOR(S) EXT (X'24'): Option (customizing)	5-110
(38) READ DMA EXT (X'25'): Option (customizing)	5-111
(39) READ NATIVE MAX ADDRESS EXT (X'27'): Option (customizing)	5-112
(40) READ MULTIPLE EXT (X'29'): Option (customizing)	5-113
(41) READ LOG EXT (X'2F') [Optional command (Customize)]	5-114
(42) WRITE SECTOR(S) EXT (X'34'): Option (customizing)	5-116
(43) WRITE DMA EXT (X'35'): Option (customizing)	5-117
(44) SET MAX ADDRESS EXT (X'37'): Option (customizing)	5-118
(45) WRITE MULTIPLE EXT (X'39'): Option (customizing)	5-120
(46) WRITE DMA FUA EXT (X'3D'): Option (customizing)	5-121

(47) WRITE LOG EXT (X'3F') [Optional command (Customize)]	5-122
(48) READ VERIFY SECTOR(S) EXT (X'42): Option (customizing)	5-124
(49) WRITE MULTIPLE FUA EXT (X'CE'): Option (customizing)	5-125
(50) FLUSH CACHE EXT (X'EA'): Option (customizing)	5-126
5.3.3 Error posting	5-127
5.4 Command Protocol	5-129
5.4.1 PIO Data transferring commands from device to host	5-129
5.4.2 PIO Data transferring commands from host to device	5-132
5.4.3 Commands without data transfer	5-134
5.4.4 Other commands	5-135
5.4.5 DMA data transfer commands	5-135
5.5 Ultra DMA Feature Set	5-137
5.5.1 Overview	5-137
5.5.2 Phases of operation	5-138
5.5.3 Ultra DMA data in commands	5-138
5.5.4 Ultra DMA data out commands	5-143
5.5.5 Ultra DMA CRC rules	5-147
5.5.6 Series termination required for Ultra DMA	5-148
5.6 Timing	5-149
5.6.1 PIO data transfer	5-149
5.6.2 Multiword data transfer	5-150
5.6.3 Ultra DMA data transfer	5-151
5.6.4 Power-on and reset	5-164
CHAPTER 6 Operations	6-1
6.1 Device Response to the Reset	6-2
6.1.1 Response to power-on	6-2
6.1.2 Response to hardware reset	6-3
6.1.3 Response to software reset	6-5
6.1.4 Response to diagnostic command	6-6
6.2 Power Save	6-7

6.2.1 Power save mode	6-7
6.2.2 Power commands.....	6-9
6.3 Defect Processing	6-9
6.3.1 Spare area	6-9
6.3.2 Alternating processing for defective sectors.....	6-10
6.4 Read-ahead Cache	6-12
6.4.1 DATA buffer structure	6-12
6.4.2 Caching operation.....	6-13
6.4.3 Using the read segment buffer	6-15
6.5 Write Cache	6-18
6.5.1 Cache operation	6-18
Glossary	GL-1
Acronyms and Abbreviations	AB-1
Index	IN-1

Illustrations

Figures

Figure 1.1	Permissible range of +5V rise slope	1-7
Figure 1.2	The example of negative voltage waveform at +5 V when power is turned off.....	1-8
Figure 1.3	Current fluctuation (Typ.) at +5 V when power is turned on	1-10
Figure 2.1	Disk drive outer view	2-2
Figure 2.2	1 drive system configuration	2-3
Figure 2.3	2 drives configuration.....	2-4
Figure 3.1	Dimensions	3-2
Figure 3.2	Mounting frame structure	3-3
Figure 3.3	Location of breather	3-4
Figure 3.4	Surface temperature measurement points	3-5
Figure 3.5	Service area	3-6
Figure 3.6	Handling cautions	3-7
Figure 3.7	Connector locations	3-8
Figure 3.8	Cable connections.....	3-9
Figure 3.9	Power supply connector pins (CN1).....	3-10
Figure 3.10	Jumper location	3-10
Figure 3.11	Factory default setting	3-11
Figure 3.12	Jumper setting of master or slave drive	3-11
Figure 3.13	CSEL setting.....	3-12
Figure 3.14	Example (1) of cable select	3-12
Figure 3.15	Example (2) of cable select	3-13
Figure 4.1	Power supply configuration.....	4-4
Figure 4.2	Circuit configuration	4-5
Figure 4.3	Power-on operation sequence.....	4-6
Figure 4.4	Read/write circuit block diagram.....	4-9
Figure 4.5	Frequency characteristic of programmable filter.....	4-10
Figure 4.6	Block diagram of servo control circuit	4-12
Figure 4.7	Physical sector servo configuration on disk surface.....	4-16
Figure 4.8	Servo frame format.....	4-17

Figure 5.1	Interface signals	5-2
Figure 5.2	Execution example of READ MULTIPLE command	5-63
Figure 5.3	READ SECTOR(S) COMMAND protocol.....	5-130
Figure 5.4	Protocol for command abort	5-131
Figure 5.5	WRITE SECTOR(S) command protocol	5-133
Figure 5.6	Protocol for the command execution without data transfer	5-135
Figure 5.7	Normal DMA data transfer	5-136
Figure 5.8	Ultra DMA termination with pull-up or pull-down	5-148
Figure 5.9	PIO data transfer timing.....	5-149
Figure 5.10	Multiword DMA data transfer timing (mode 2)	5-150
Figure 5.11	Initiating an Ultra DMA data in burst.....	5-151
Figure 5.12	Sustained Ultra DMA data in burst.....	5-155
Figure 5.13	Host pausing an Ultra DMA data in burst	5-156
Figure 5.14	Device terminating an Ultra DMA data in burst.....	5-157
Figure 5.15	Host terminating an Ultra DMA data in burst	5-158
Figure 5.16	Initiating an Ultra DMA data out burst.....	5-159
Figure 5.17	Sustained Ultra DMA data out burst.....	5-160
Figure 5.18	Device pausing an Ultra DMA data out burst.....	5-161
Figure 5.19	Host terminating an Ultra DMA data out burst	5-162
Figure 5.20	Device terminating an Ultra DMA data out burst.....	5-163
Figure 5.21	Power-on reset timing.....	5-164
Figure 6.1	Response to power-on.....	6-3
Figure 6.2	Response to hardware reset.....	6-4
Figure 6.3	Response to software reset.....	6-5
Figure 6.4	Response to diagnostic command.....	6-6
Figure 6.5	Sector slip processing	6-10
Figure 6.6	Automatic alternating processing	6-11
Figure 6.7	Data buffer structure	6-12

Tables

Table 1.1 Specifications.....	1-5
Table 1.2 Examples of model names and product numbers.....	1-6
Table 1.3 Current and power dissipation	1-9
Table 1.4 Environmental specifications.....	1-10
Table 1.5 Acoustic noise specification	1-11
Table 1.6 Shock and vibration specifications	1-11
Table 1.7 Advanced Power Management	1-15
Table 3.1 Surface temperature measurement points and standard values.....	3-5
Table 3.2 Cable connector specifications	3-9
Table 5.1 Signal assignment on the interface connector.....	5-3
Table 5.2 I/O registers.....	5-7
Table 5.3 Command code and parameters	5-15
Table 5.4 Diagnostic code.....	5-28
Table 5.5 Operation of DOWNLOAD MICROCODE.....	5-32
Table 5.6 Example of rewriting procedure of data 512 KBytes (40000h Bytes) of microcode.....	5-32
Table 5.7 Features register values (subcommands) and functions.....	5-42
Table 5.8 Format of device attribute value data.....	5-46
Table 5.9 Format of insurance failure threshold value data.....	5-46
Table 5.10 Off-line data collection status	5-49
Table 5.11 Self-test execution status.....	5-49
Table 5.12 Off-line data collection capability	5-50
Table 5.13 Failure prediction capability flag.....	5-50
Table 5.14 Error logging capability	5-51
Table 5.15 Log directory data format	5-51
Table 5.16 Data format of SMART Summary Error Log.....	5-53
Table 5.17 Data format of SMART Comprehensive Error Log	5-54
Table 5.18 SMART self-test log data format.....	5-55
Table 5.19 Selective self-test log data structure.....	5-56
Table 5.20 Selective self-test feature flags	5-57
Table 5.21 DEVICE CONFIGURATION IDENTIFY data structure	5-61
Table 5.22 Information to be read by IDENTIFY DEVICE command.....	5-78
Table 5.23 Features register values and settable modes.....	5-89
Table 5.24 Contents of SECURITY SET PASSWORD data.....	5-93
Table 5.25 Relationship between combination of Identifier and Security level, and operation of the lock function	5-93
Table 5.26 Contents of security password	5-101
Table 5.27 Command code and parameters	5-127

Table 5.28 Recommended series termination for Ultra DMA	5-148
Table 5.29 Ultra DMA data burst timing requirements	5-152
Table 5.30 Ultra DMA sender and recipient timing requirements.....	5-154

CHAPTER 1 Device Overview

- 1.1 Features
- 1.2 Device Specifications
- 1.3 Power Requirements
- 1.4 Environmental Specifications
- 1.5 Acoustic Noise
- 1.6 Shock and Vibration
- 1.7 Reliability
- 1.8 Error Rate
- 1.9 Media Defects
- 1.10 Load/Unload Function
- 1.11 Advanced Power Management (APM)

Overview and features are described in this chapter, and specifications and power requirement are described.

The disk drive is 2.5-inch hard disk drive with built-in disk controller. This disk drive uses the AT-bus hard disk interface protocol and are compact and reliable.

1.1 Features

1.1.1 Functions and performance

The following features of the disk drive are described.

(1) Compact

The disk drive has up to 1 disk of 65 mm (2.5 inches) diameter, and its height is 9.5 mm (0.374 inch).

(2) Environmental Protection

The disk drive complies with the Restriction of the use of certain Hazardous Substances in electrical and electronic equipment (RoHS) directive issued by European Union (EU).

(3) Large capacity

The disk drive can record up to 60 GB (formatted) on one disk using the RLL recording method and 30 recording zone technology. The disk drive has a formatted capacity of 60 GB (MHW2060AC) and 40 GB (MHW2040AC) respectively.

(4) High-speed Transfer rate

The disk drive has an internal data rate up to 48.9 MB/s. The disk drive supports an external data rate up to 100 MB/s (U-DMA mode 5).

(5) Average positioning time

Use of a rotary voice coil motor in the head positioning mechanism greatly increases the positioning speed. The average positioning time is 12 ms (at read).

1.1.2 Adaptability

(1) Power save mode

The power save mode feature for Idle operation, Standby and Sleep modes and automatically power down by APM function makes the disk drive ideal for mobile use where power consumption is a factor.

(2) Wide temperature range

The disk drive can be used over a wide temperature range (-30 °C to 90 °C or -20 °C to 85 °C at DE surface for each model).

(3) Low noise and vibration

In Ready status (while the device is waiting for any commands), the Sound Power level of the disk drive in idle mode is 1.5 B. The Sound Pressure level is 17 dB, as measured 0.3 m from the drive in Idle mode.

(4) High resistance against shock

The Load/Unload mechanism is highly resistant against non-operation shock up to 8820 m/s² (900G).

1.1.3 Interface**(1) Connection to ATA interface**

The disk drive has built-in controller compatible with the ATA interface.

(2) Data buffer

The disk drive uses a data buffer to transfer data between the host and the disk media.

In combination with the read-ahead cache system described in item (3) and the write cache described in item (7), the buffer contributes to efficient I/O processing.

(3) Read-ahead cache system

After the execution of a disk read command, the disk drive automatically reads the subsequent data block and writes it to the data buffer (read ahead operation). This cache system enables fast data access. The next disk read command would normally cause another disk access. But, if the read ahead data corresponds to the data requested by the next read command, the data in the buffer can be transferred instead.

(4) Master/slave

The disk drive can be connected to ATA interface as daisy chain configuration. Drive 0 is a master device, drive 1 is a slave device.

(5) Error correction and retry by ECC

If a recoverable error occurs, the disk drive itself attempts error recovery. The ECC has improved buffer error correction for correctable data errors.

(6) Self-diagnosis

The disk drive has a diagnostic function to check operation of the controller and disk drive. Executing a diagnostic function of the smart command invokes self-diagnosis.

(7) Write cache

When the disk drive receives a write command, the disk drive posts the command completion at completion of transferring data to the data buffer completion of writing to the disk media. This feature reduces the access time at writing.

(8) Drive-specific function (specification)

The disk drive measures the environment temperature. When the temperature becomes about -20°C or lower, some of the functions of internal drive operation are automatically changed. The functions to be changed are listed below.

1) Receiving Write-related commands (writing data into user areas)

The disk drive disables the Write cache function, which is described at (7), writes data into user areas, and automatically performs the data verify operation (Read check) for those areas.

2) SMART operation

While the SMART function is enabled, a SMART attribute value or other data may be written into the system area of the disk drive for periodic information storage. When the temperature becomes lower than the specified value, however, the data is only updated in the memory of the disk drive and not written into the system area (temporarily suspended).

1.2 Device Specifications

1.2.1 Specifications summary

Table 1.1 shows the specifications of the disk drive.

Table 1.1 Specifications (1 of 2)

	MHW2060AC	MHW2040AC
Format Capacity (*1)	60 GB	40 GB
Number of Sectors (User)	117,210,240	78,140,160
Bytes per Sector	512 bytes	
Rotational Speed	4,200 rpm \pm 1%	
Average Latency	7.14 ms	
Positioning time (read and seek)		
Minimum (Track-Track)	1.5 ms (typ.)	
Average	Read: 12ms (typ.)	
Maximum (Full)	22 ms (typ.)	
Start time	3.5 sec (typ.)	
Interface	ATA-6/ATA-7 (Max. Cable length: 18inches (0.46 m)) (equipped with expansion function)	
Data Transfer Rate (*2)		
To/From Media	48.9 MB/s Max.	
To/From Host	100 MB/s Max (U-DMA mode5)	
Data Buffer Size (*3)	8 MB (8,388,608 bytes)	
Physical Dimensions (Height \times Width \times Depth)	9.5 mm \times 100.0 mm \times 70.0 mm	
Weight	96 g (max)	

*1: One gigabyte (GB) = one billion bytes; accessible capacity will be less and actual capacity depends on the operating environment and formatting.

*2: 1MB is equal to 1,000,000 bytes.

*3: 1MB is equal to 1,048,576 bytes; the actual buffer capacity for data transfer will be less. Refer to the Section 6.4 in this manual.

Table 1.1 lists the formatted capacity, number of logical cylinders, number of heads, and number of sectors of every model for which the CHS mode has been selected using the BIOS setup utility on the host.

Table 1.1 Specifications (2 of 2)

Model	Capacity (*)	No. of Cylinder	No. of Heads	No. of Sectors
MHW2060AC	8.45 GB	16,383	16	63
MHW2040AC	8.45 GB	16,383	16	63

(*) One gigabyte (GB) = one billion bytes; accessible capacity will be less and actual capacity depends on the operating environment and formatting.

1.2.2 Model and product number

Table 1.2 lists the model name and product number of the disk drive.

The model name does not necessarily correspond to the product number as listed in Table 1.2 since some models have been customized and have specifications that are different from those for the standard model.

If a disk drive is ordered as a replacement drive, the product number must be the same as that of the drive being replaced.

Table 1.2 Examples of model names and product numbers

Model Name	Capacity (*) (user area)	Mounting screw	Order No.
MHV2060AC	60 GB	M3 Depth 3	CA06821-B906
MHV2040AC	40 GB	M3 Depth 3	CA06821-B900/B902

(*) One gigabyte (GB) = one billion bytes; accessible capacity will be less and actual capacity depends on the operating environment and formatting.

1.3 Power Requirements

(1) Input Voltage

- +5 V \pm 5 %

(2) Ripple

	+5 V
Maximum	100 mV (peak to peak)
Frequency	DC to 1 MHz

(3) Slope of an input voltage at rise

The following figure shows the restriction of the slope which is +5 V input voltage at rise. The permissible range of +5 V slope is from 1V/20 μ sec to 1V/20 msec, under the voltage range is between 2.0 V and 4.5 V.

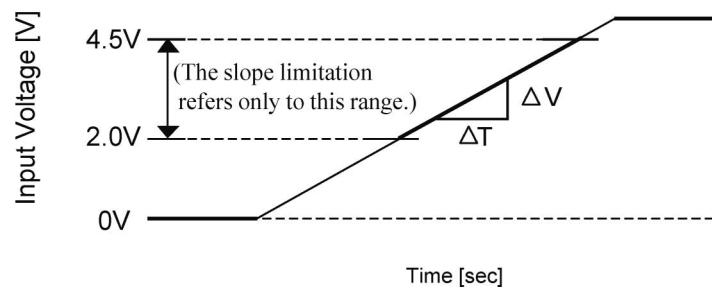

$$\text{Slope : } S = \Delta V / \Delta T \text{ [V/sec]}$$

$$S : \underline{1V/20\mu\text{s to } 1V/20\text{ms}}$$

Figure 1.1 Permissible range of +5V rise slope

- (4) A negative voltage like the bottom figure isn't to occur at +5 V when power is turned off and, a thing with no ringing.

Permissible level: -0.2 V

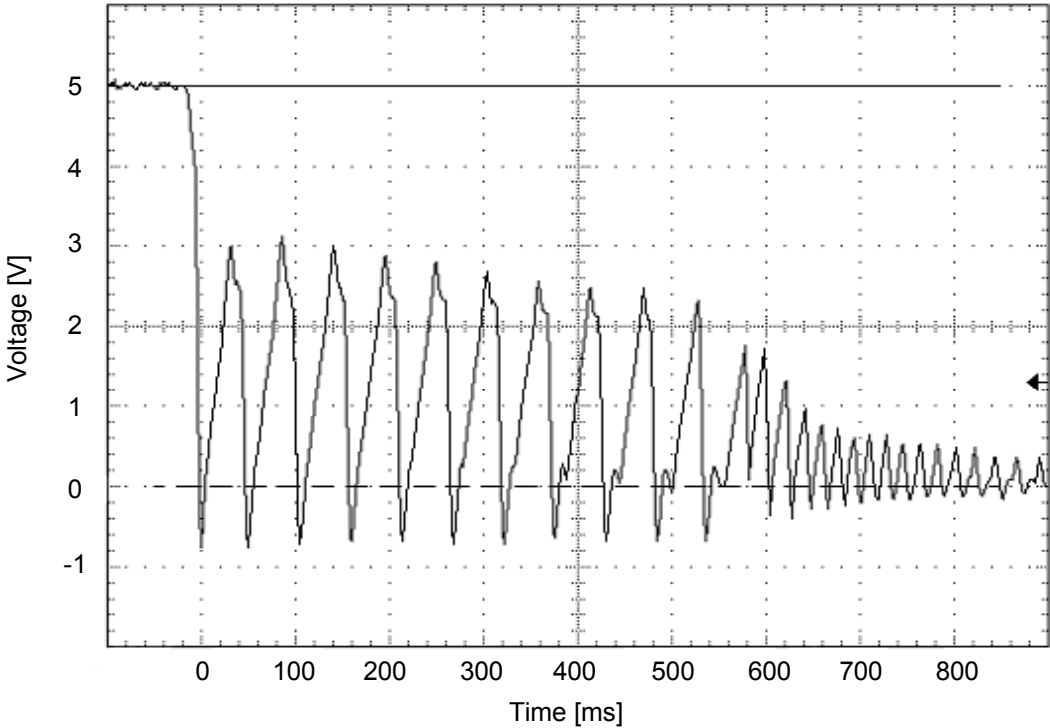

Figure 1.2 The example of negative voltage waveform at +5 V when power is turned off

(5) Current Requirements and Power Dissipation

Table 1.3 lists the current and power dissipation (typical).

Table 1.3 Current and power dissipation

	Typical RMS Current	Typical Power (*3)
Spin up (*1)	1.2 A	6.0 W
Idle	140 mA	0.70 W
R/W (on track) (*2)	360 mA	1.8 W
Seek (*5)	420 mA	2.1 W
Standby	40 mA	0.20 W
Sleep	20 mA	0.1 W
Energy Efficiency (*4)	—	d rank (0.0117 W/GB): MHW2060AC d rank (0.0175 W/GB): MHW2040AC

- *1 Maximum current at starting spindle motor.
- *2 Current and power level when the operation (command) that accompanies a transfer of 63 sectors is executed 3 times in 100 ms
- *3 Power requirements reflect typical values for +5 V power.
- *4 Energy efficiency based on the Law concerning the Rational Use of Energy indicates the value obtained by dividing power consumption by the storage capacity. (Japan only)
- *5 The seek average current is specified based on three operations per 100 msec.

(6) Current fluctuation (Typ.) at +5 V when power is turned on

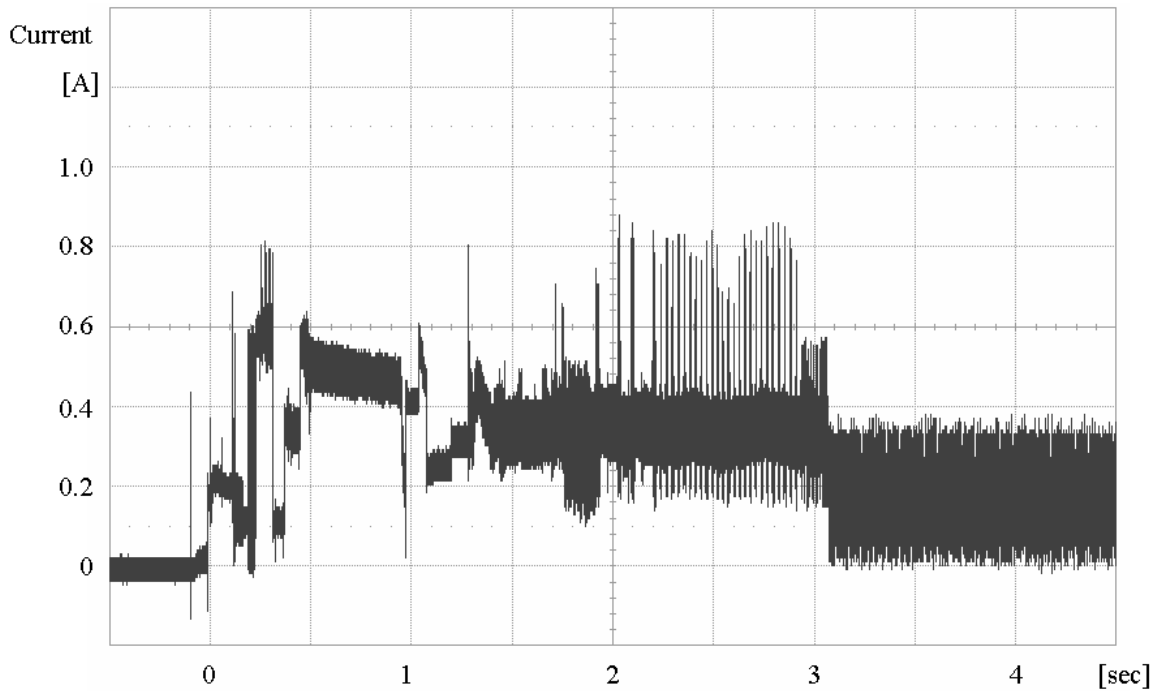

Figure 1.3 Current fluctuation (Typ.) at +5 V when power is turned on

1.4 Environmental Specifications

Table 1.4 lists the environmental specifications.

Table 1.4 Environmental specifications

Item	Specification	
Temperature	CA06821-B900 (MHW2040AC)	CA06821-B906 (MHW2060AC) CA06821-B902 (MHW2040AC)
<ul style="list-style-type: none"> • Operating • Non-operating • Thermal Gradient 	<ul style="list-style-type: none"> - 30 °C to 85 °C (ambient) - 30 °C to 90 °C (Disk enclosure cover surface) - 40 °C to 85 °C 20 °C/h or less 	<ul style="list-style-type: none"> - 20 °C to 80 °C (ambient) - 20 °C to 85 °C (Disk enclosure cover surface) - 40 °C to 85 °C 20 °C/h or less
Humidity	<ul style="list-style-type: none"> • Operating • Non-operating • Maximum Wet Bulb 	
	<ul style="list-style-type: none"> 8 % to 90 % RH (Non-condensing) 5 % to 95 % RH (Non-condensing) 29 °C (Operating) 40 °C (Non-operating) 	
Altitude (relative to sea level)		
<ul style="list-style-type: none"> • Operating • Non-operating 	<ul style="list-style-type: none"> -300 to 4,000 m -300 to 12,000 m 	

1.5 Acoustic Noise

Table 1.5 lists the acoustic noise specification.

Table 1.5 Acoustic noise specification

Item	Specification (typical)
<ul style="list-style-type: none"> Idle mode (DRIVE READY) 	
Sound Power	1.5 B
Sound Pressure (at 0.3m)	17 dB

Note:

Measure the noise from the cover top surface.

1.6 Shock and Vibration

Table 1.6 lists the shock and vibration specifications.

Table 1.6 Shock and vibration specifications

Item	Specifications
Vibration (Swept sine, 1/4 octave per minute) <ul style="list-style-type: none"> Operating Non-operating 	5 to 500 Hz, 9.8m/s ² 0-peak (1G 0-peak) (without non-recovered errors) 5 to 500 Hz, 49m/s ² 0-peak (5G 0-peak) (no damage)
Shock (half-sine pulse) <ul style="list-style-type: none"> Operating Non-operating 	2940 m/s ² 0-peak (300G 0-peak) 2ms duration (without non-recovered errors) 8820 m/s ² 0-peak (900G 0-peak) 1ms duration 1176 m/s ² 0-peak (120G 0-peak) 11ms duration (no damage)

1.7 Reliability

(1) Mean time between failures (MTBF)

Conditions of 300,000 h	Power-on time	8760 H/year or less
	Operating time	20 % or less of power-on time
	Temperature	5 to 70 °C (DE surface)
	Humidity	8 to 90 % (ambient) But humidity bulb temperature 29 °C or less
		(For temperatures that exceed the DE surface temperature range (5 to 70 °C), MTBF is defined separately.)

MTBF is defined as follows:

$$\text{MTBF} = \frac{\text{Total operation time in all fields}}{\text{number of device failure in all fields (*1)}} \text{ (H)}$$

*1 “Disk drive defects” refers to defects that involve repair, readjustment, or replacement. Disk drive defects do not include failures caused by external factors, such as damage caused by handling, inappropriate operating environments, defects in the power supply host system, or interface cable.

(2) Mean time to repair (MTTR)

The mean time to repair (MTTR) is 30 minutes or less, if repaired by a specialist maintenance staff member.

(3) Service life

1) DE surface temperature -30°C to 70°C:

In situations where management and handling are correct, the disk drive requires no overhaul for five years when the DE surface temperature is less than 48°C.

When the DE surface temperature exceeds 48°C, the disk drives requires no overhaul for five years or 30,000 hours of operation, whichever occurs first.

2) DE surface temperature over 70°C:

The disk drive requires no overhaul for 2,000 hours of operation.

Refer to item (3) in Subsection 3.2 for the measurement point of the DE surface temperature. The operating conditions of Service life are based on the equal conditions with MTBF.

(4) Data assurance in the event of power failure

Except for the data block being written to, the data on the disk media is assured in the event of any power supply abnormalities. This does not include power supply

abnormalities during disk media initialization (formatting) or processing of defects (alternative block assignment).

1.8 Error Rate

Known defects, for which alternative blocks can be assigned, are not included in the error rate count below. It is assumed that the data blocks to be accessed are evenly distributed on the disk media.

(1) Unrecoverable read error

Read errors that cannot be recovered by maximum read retries of drive without user's retry and ECC corrections shall occur no more than 10 times when reading data of 10^{14} bits. Read retries are executed according to the disk drive's error recovery procedure, and include read retries accompanying head offset operations.

(2) Positioning error

Positioning (seek) errors that can be recovered by one retry shall occur no more than 10 times in 10^7 seek operations.

1.9 Media Defects

Defective sectors are replaced with alternates when the disk drive is formatted prior to shipment from the factory (low level format). Thus, the hosts see a defect-free device.

Alternate sectors are automatically accessed by the disk drive. The user need not be concerned with access to alternate sectors.

1.10 Load/Unload Function

The Load/Unload function is a mechanism that loads the head on the disk and unloads the head from the disk.

The product supports a minimum of 600,000 Load/Unload cycles. Unload is a normal head unloading operation and is executed by the operations below:

- Hard Reset
- STANDBY command issued
- STANDBY IMMEDIATE command issued
- SLEEP command issued
- IDLE IMMEDIATE command (with unload feature) issued
- Power Mode shifted with APM/APS feature

Emergency Unload other than Unload is performed when the power is shut down while the heads are still loaded on the disk.

The product supports the Emergency Unload a minimum of 20,000 times.

When the power is shut down, the controlled Unload cannot be executed.

Therefore, the number of Emergency other than Unload is specified.

1.10.1 Recommended power-off sequence

We recommend cutting the power supply of the HDD for this device after the Head Unload operation completes. The recommended power supply cutting sequence for this device is as follows:

1) Disk Flush

Flush Cache command execution.

2) Head Unload

Standby Immediate command execution.

3) Wait Status

Checking whether bit 7 of the status register was set to '0'.
(wait to complete STANDBY IMMEDIATE command)

4) HDD power supply cutting

1.11 Advanced Power Management (APM)

The disk drive automatically shifts to the power saving mode according to the setting of the APM mode under the idle condition.

The APM mode can be chosen with a Sector Count register of the SET FEATURES (EF) command.

The disk drive complies with the three kinds of APM modes that a command from the host is required.

FR = 05h : Enable APM

SC = C0h - FEh : Mode-0 Active Idle → Low Power Idle

SC = 80h - BFh : Mode-1 Active Idle → Low Power Idle (Default)

SC = 01h - 7Fh : Mode-2 Active Idle → Low Power Idle → Standby

FR = 85h : Disable APM (Set Mode-0)

Active Idle: The head is in a position of extreme inner in disk medium. (VCM Lock)

Low Power Idle: The head is unloaded from disk.
The spindle motor rotates.

Standby: The spindle motor stops.

In APM Mode-1, which is the APM default mode, the operation status shifts till it finally reaches "Low Power Idle."

Table 1.7 Advanced Power Management

APM Mode	Active Idle (VCM Lock)	Low Power Idle (Unload)	Standby (Spin Off)
Mode-0	0.2-1.2 sec	15 min.	N/A
Mode-1	0.2-1.2 sec	10.0-40.0 sec	N/A
Mode-2	0.2-1.2 sec	10.0-40.0 sec	10.0-60.0 sec

When the maximum time that the HDD is waiting for commands has been exceeded:

Mode-0: Mode shifts from Active condition to Active Idle in 0.2-1.2, and to Low Power Idle in 15 minutes.

Mode-1: Mode shifts from Active condition to Active Idle in 0.2-1.2 seconds and to Low Power Idle in 10.0-40.0 seconds.

Mode-2: Mode shifts from Active condition to Active Idle in 0.2-1.2 seconds and to Low Power Idle in 10.0-40.0 seconds. After 10.0-60.0 seconds in Low Power Idle, the mode shifts to standby.

Remark:

The default values of these settings are reflected in the WORD 91 values of the IDENTIFY DEVICE command. Also, the APM mode is initialized to Mode-1 (default value) by hardware reset and at power-off.

The above-mentioned is time until shifting to each power mode based on point that the drive becomes a command waiting state.

This page is intentionally left blank.

CHAPTER 2 Device Configuration

2.1 Device Configuration

2.2 System Configuration

This chapter describes the internal configurations of the hard disk drive and the configuration of the systems in which they operate.

2.1 Device Configuration

Figure 2.1 shows the disk drive. The disk drive consists of a disk enclosure (DE), read/write preamplifier, and controller PCA. The disk enclosure contains the disk media, heads, spindle motor, actuator, and a circulating air filter.

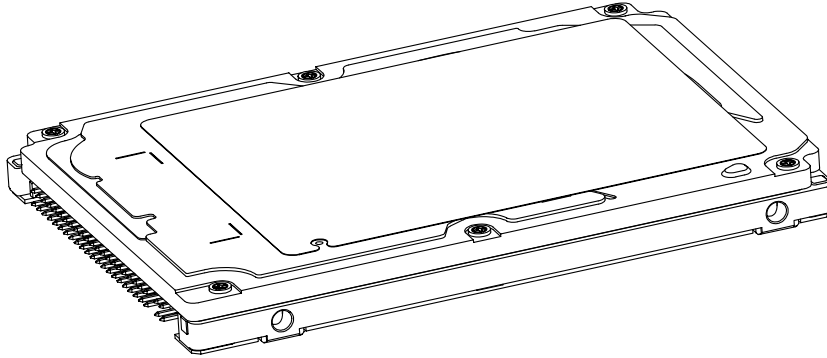

Figure 2.1 Disk drive outer view

(1) Disk

The outer diameter of the disk is 65 mm. The inner diameter is 20 mm.

(2) Head

The heads are of the load/unload (L/UL) type. The head unloads the disk out of while the disk is not rotating and loads on the disk when the disk starts.

(3) Spindle motor

The disks are rotated by a direct drive Sensor-less DC motor.

(4) Actuator

The actuator uses a revolving voice coil motor (VCM) structure which consumes low power and generates very little heat. The head assembly at the edge of the actuator arm is controlled and positioned by feedback of the servo information read by the read/write head. If the power is not on or if the spindle motor is stopped, the head assembly stays on the ramp out of the disk and is fixed by a mechanical lock.

(5) Air circulation system

The disk enclosure (DE) is sealed to prevent dust and dirt from entering. The disk enclosure features a closed loop air circulation system that relies on the blower effect of the rotating disk. This system continuously circulates the air through the circulation filter to maintain the cleanliness of the air within the disk enclosure.

(6) Read/write circuit

The read/write circuit uses a LSI chip for the read/write preamplifier. It improves data reliability by preventing errors caused by external noise.

(7) Controller circuit

The controller circuit consists of an LSI chip to improve reliability. The high-speed microprocessor unit (MPU) achieves a high-performance AT controller.

2.2 System Configuration

2.2.1 ATA interface

Figures 2.2 and 2.3 show the ATA interface system configuration. The drive has a 44pin PC AT interface connector and supports PIO mode 4 transfer at 16.6 MB/s, Multiword DMA mode 2 transfer at 16.6 MB/s and also U-DMA mode 5 (100 MB/s).

2.2.2 1 drive connection

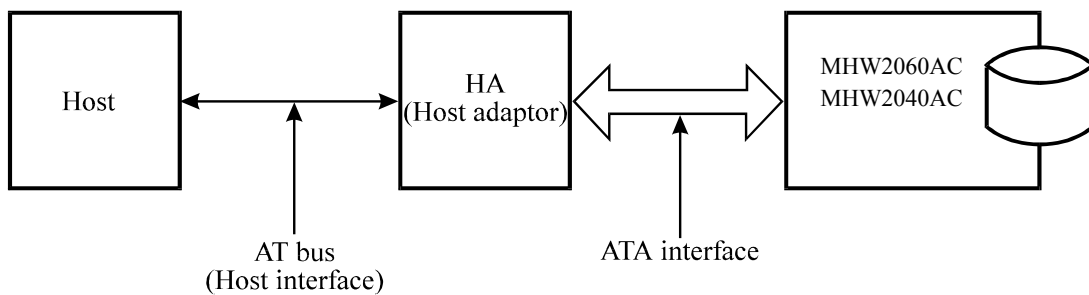
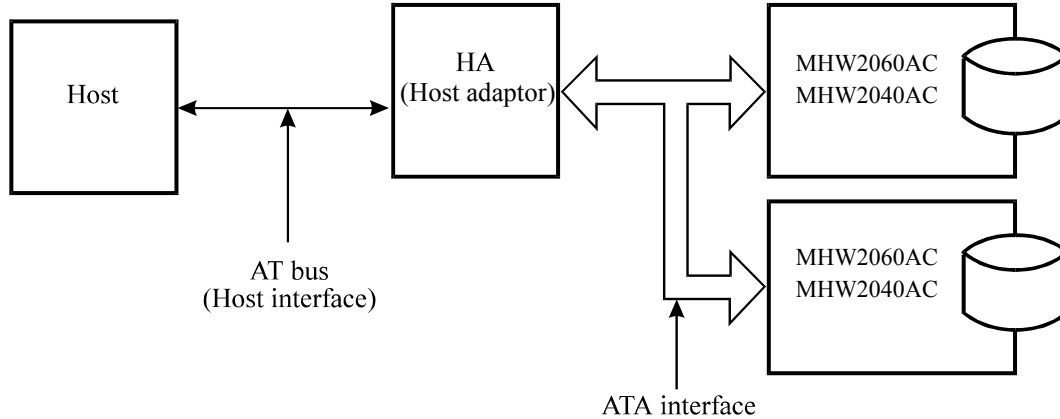

Figure 2.2 1 drive system configuration

2.2.3 2 drives connection



Note:

When the drive that is not conformed to ATA is connected to the disk drive above configuration, the operation is not guaranteed.

Figure 2.3 2 drives configuration

IMPORTANT

HA (host adaptor) consists of address decoder, driver, and receiver. ATA is an abbreviation of "AT attachment". The disk drive is conformed to the ATA-6/ATA-7 interface.

At high-speed data transfer (PIO mode 4 or DMA mode 2 U-DMA mode 5), occurrence of ringing or crosstalk of the signal lines (AT bus) between the HA and the disk drive may be a great cause of the obstruction of system reliability. Thus, it is necessary that the capacitance of the signal lines including the HA and cable does not exceed the ATA-6/ATA-7 standard, and the cable length between the HA and the disk drive should be as short as possible.

No need to push the top cover of the disk drive. If the over-power worked, the cover could be contacted with the spindle motor. Thus, that could be made it the cause of failure.

CHAPTER 3 Installation Conditions

- 3.1 Dimensions
- 3.2 Mounting
- 3.3 Cable Connections
- 3.4 Jumper Settings

This chapter gives the external dimensions, installation conditions, surface temperature conditions, cable connections, and switch settings of the hard disk drive.

For information about handling this hard disk drive and the system installation procedure, refer to the following Integration Guide. (C141-E144)

3.1 Dimensions

Figure 3.1 illustrates the dimensions of the disk drive and positions of the mounting screw holes. All dimensions are in mm.

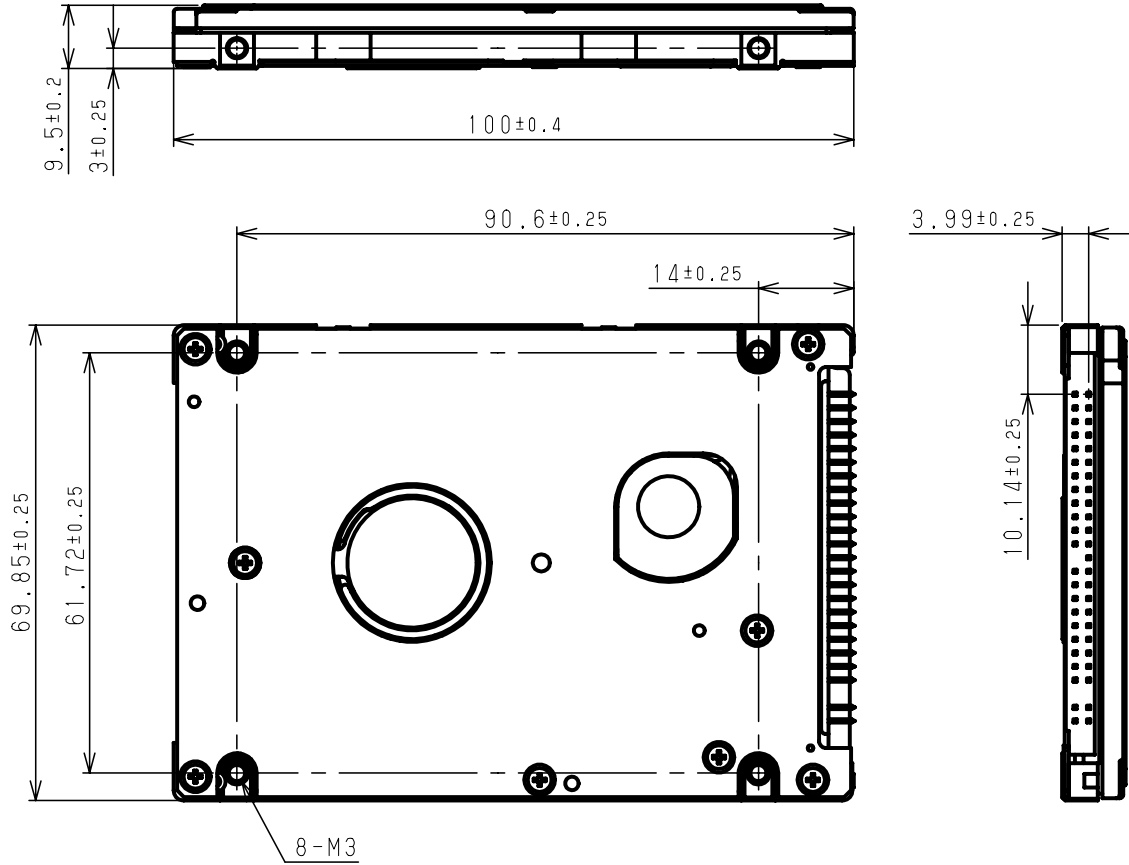

Figure 3.1 Dimensions

3.2 Mounting

For information on mounting, see the "FUJITSU 2.5-INCH HDD INTEGRATION GUIDANCE (C141-E144)."

(1) Orientation

The disk drive can be mounted in any direction.

(2) Frame

The MR head bias of the HDD disk enclosure (DE) is zero. The mounting frame is connected to SG.

IMPORTANT

Use M3 screw for the mounting screw and the screw length should satisfy the specifications in Figure 3.2.

The tightening torque must be $0.49\text{N}\cdot\text{m}$ ($5\text{kgf}\cdot\text{cm}$).

When attaching the HDD to the system frame, do not allow the system frame to touch parts (cover and base) other than parts to which the HDD is attached.

(3) Limitation of mounting

Note) These dimensions are recommended values; if it is not possible to satisfy them, contact us.

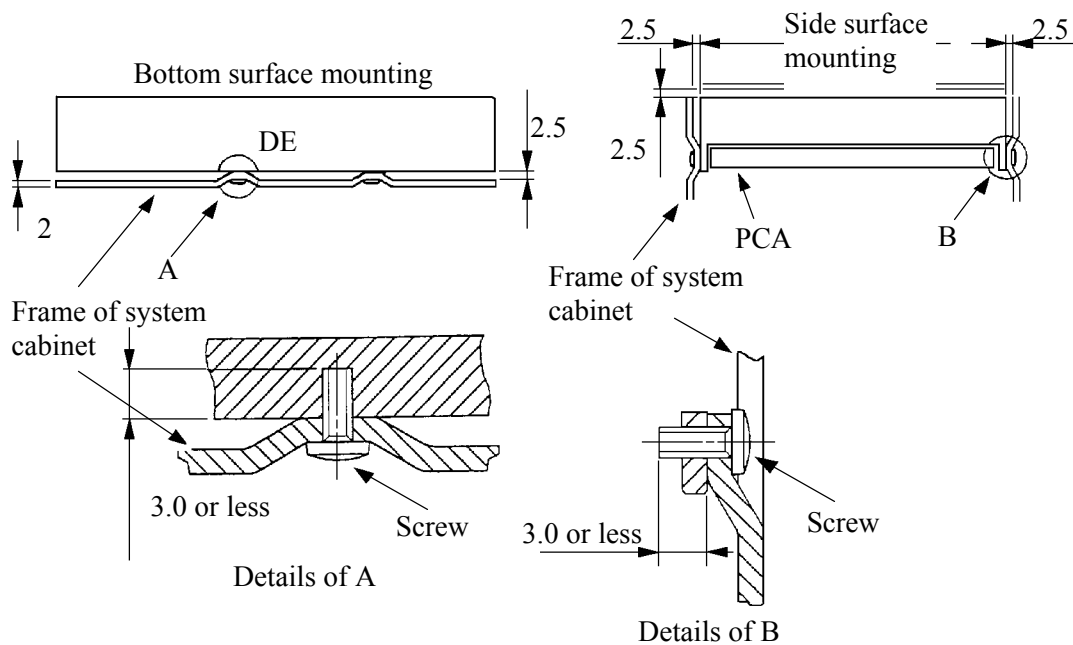

Figure 3.2 Mounting frame structure

IMPORTANT

Because of breather hole mounted to the HDD, do not allow this to close during mounting.

Locating of breather hole is shown as Figure 3.3.

For breather hole of Figure 3.3, at least, do not allow its around $\phi 3$ to block.

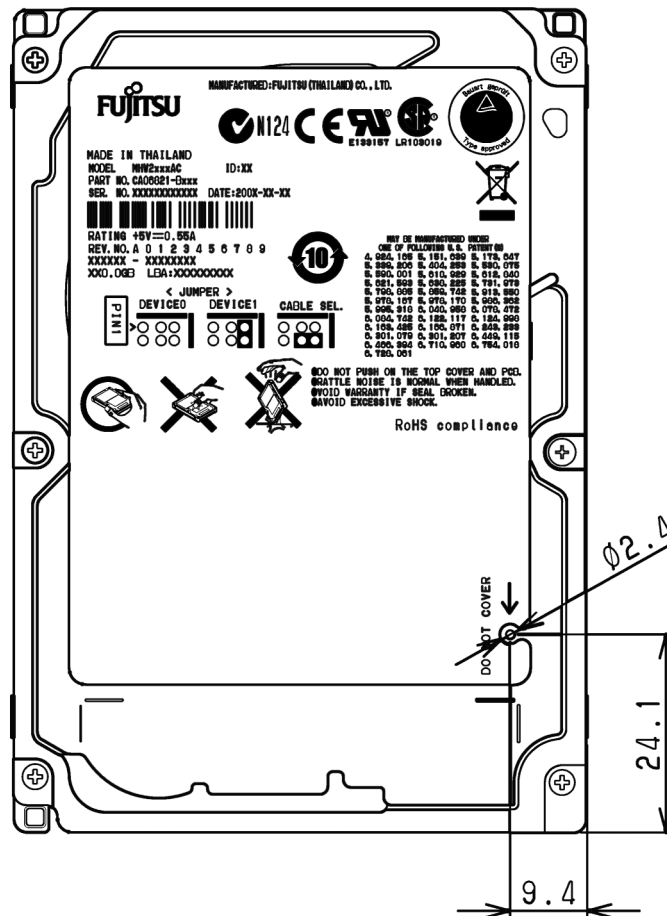

Figure 3.3 Location of breather

(4) Ambient temperature

The temperature conditions for a disk drive mounted in a cabinet refer to the ambient temperature at a point 3 cm from the disk drive. The ambient temperature must satisfy the temperature conditions described in Section 1.4, and the airflow must be considered to prevent the DE cover surface temperature from exceeding standard values.

Provide air circulation in the cabinet such that the PCA side, in particular, receives sufficient cooling. To check the cooling efficiency, measure the surface temperatures of the DE. Regardless of the ambient temperature, this surface temperature must meet the standards listed in Table 3.1. Figure 3.4 shows the temperature measurement point.

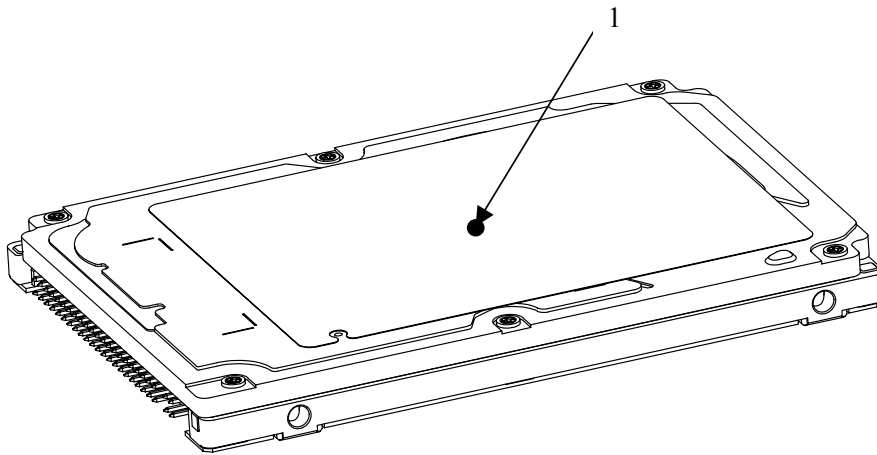

Figure 3.4 Surface temperature measurement points

Table 3.1 Surface temperature measurement points and standard values

No.	Measurement point	Temperature	Order No.
1	DE cover surface	90 °C	CA06821-B900 (MHW2040AC)
		85 °C	CA06821-B906 (MHW2060AC) CA06821-B902 (MHW2040AC)

(5) Service area

Figure 3.5 shows how the drive must be accessed (service areas) during and after installation.

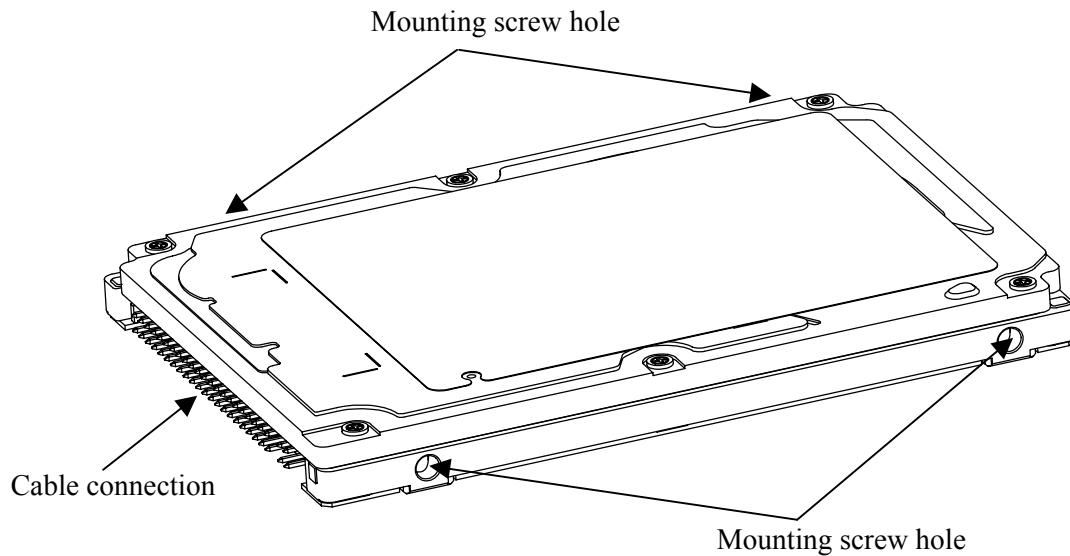

Figure 3.5 Service area

CAUTION

Data corruption: Avoid mounting the disk drive near strong magnetic sources such as loud speakers. Ensure that the disk drive is not affected by external magnetic fields.

Damage: Do not press the cover of the disk drive. Pressing it too hard, the cover and the spindle motor contact, which may cause damage to the disk drive.

Static: When handling the device, disconnect the body ground (500 k Ω or greater). Do not touch the printed circuit board, but hold it by the edges.

(6) Handling cautions

Please keep the following cautions, and handle the HDD under the safety environment.

- **General notes**

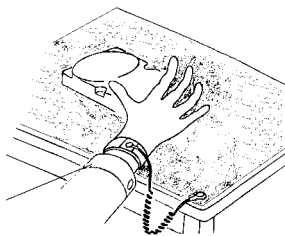

Wrist strap

Use the Wrist strap.



Shock absorbing mat

Place the shock absorbing mat on the operation table, and place ESD mat on it.

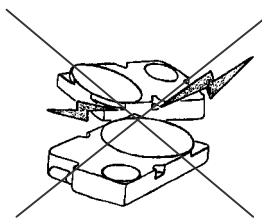

Do not hit HDD each other.

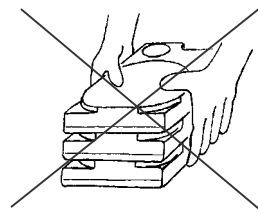

Do not stack when carrying.

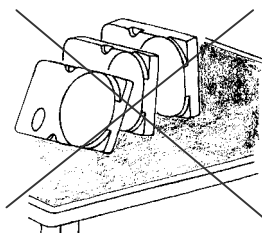

Do not place HDD vertically to avoid falling down.

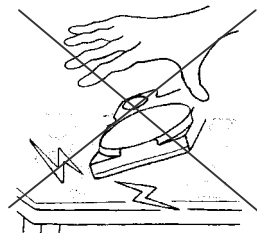

Do not drop.

Figure 3.6 Handling cautions

- **Installation**

- (1) Please use the driver of a low impact when you use an electric driver.
HDD is occasionally damaged by the impact of the driver.
- (2) Please observe the tightening torque of the screw strictly.
M3 0.49N•m (5 kgf•cm).

- **Recommended equipments**

	Contents	Model	Maker
ESD	Wrist strap	JX-1200-3056-8	SUMITOMO 3M
	ESD mat	SKY-8A (Color Seiden Mat)	Achilles
Shock	Low shock driver	SS-6500	HIOS

3.3 Cable Connections

3.3.1 Device connector

The disk drive has the connectors and terminals listed below for connecting external devices. Figure 3.7 shows the locations of these connectors and terminals.

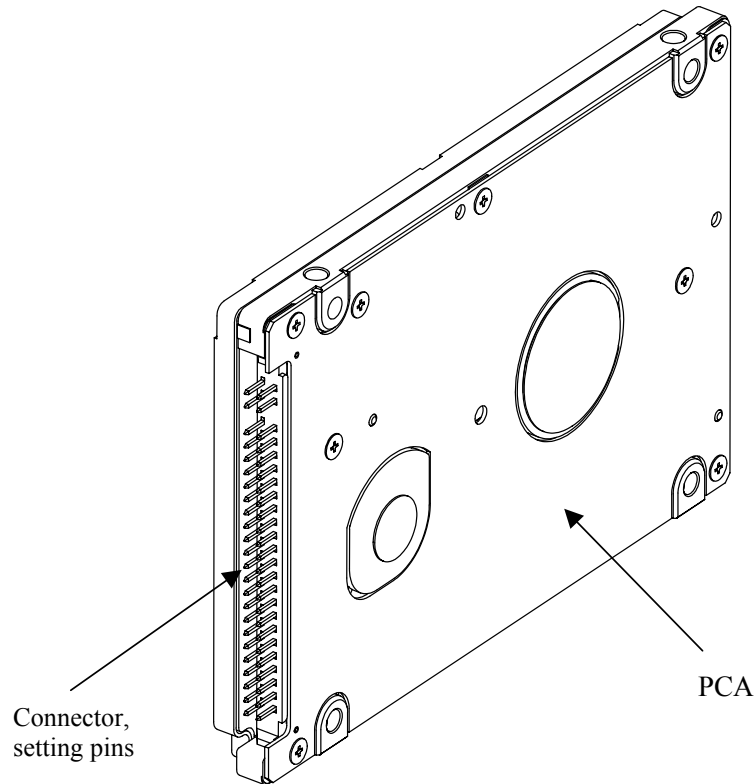

Figure 3.7 Connector locations

3.3.2 Cable connector specifications

Table 3.2 lists the recommended specifications for the cable connectors.

Table 3.2 Cable connector specifications

	Name	Model	Manufacturer
ATA interface and power supply cable (44-pin type)	Cable socket (44-pin type)	89361-144	FCI

IMPORTANT

For the host interface cable, use a ribbon cable. A twisted cable or a cable with wires that have become separated from the ribbon may cause crosstalk between signal lines. This is because the interface is designed for ribbon cables and not for cables carrying differential signals.

3.3.3 Device connection

Figure 3.8 shows how to connect the devices.

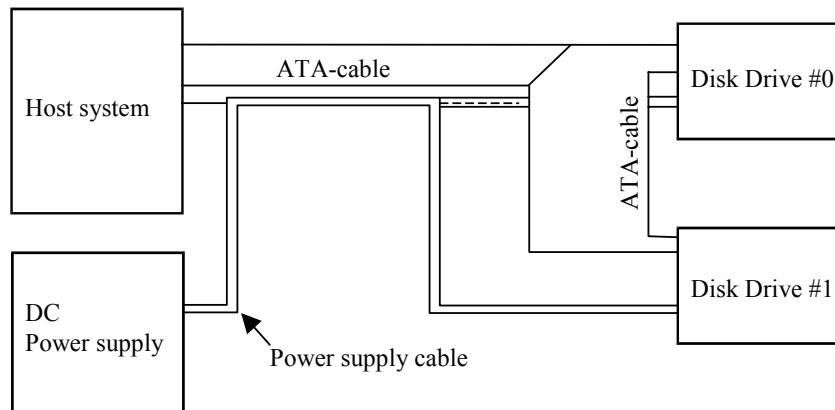

Figure 3.8 Cable connections

CAUTION

Damage: Interface cable connection

Take note of the following precaution about plugging an interface cable (socket) into the interface connector of the disk drive and plugging the connector into a host receptacle:

- When plugging together the disk drive interface connector and the host receptacle or interface cable connector (socket), do not apply more than 10 kgf of force in the connection direction once they are snugly and securely in position.

3.3.4 Power supply connector (CN1)

Figure 3.9 shows the pin assignment of the power supply connector (CN1).

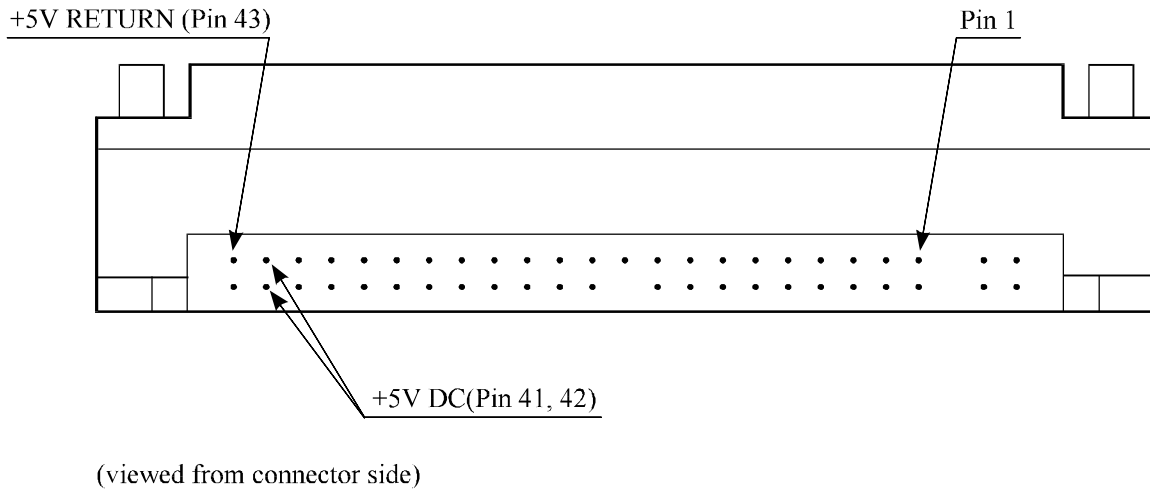

Figure 3.9 Power supply connector pins (CN1)

3.4 Jumper Settings

3.4.1 Location of setting jumpers

Figure 3.10 shows the location of the jumpers to select drive configuration and functions.

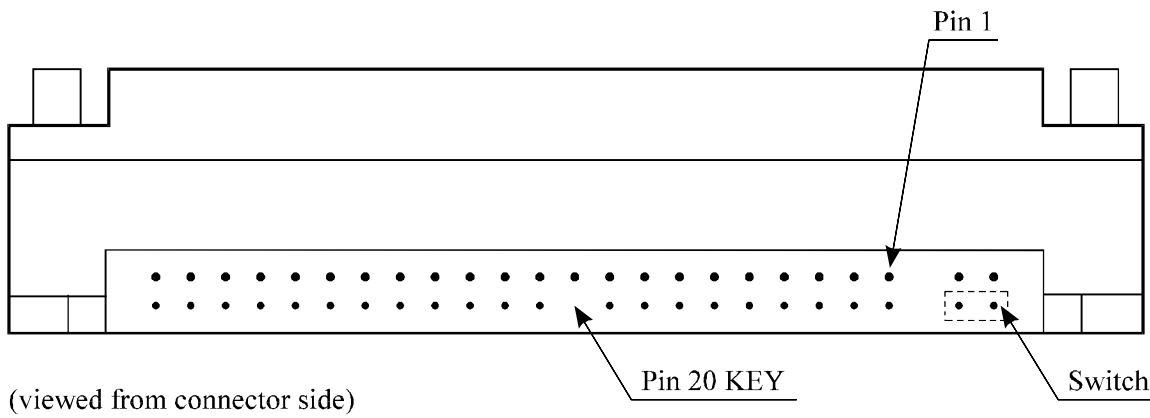

Figure 3.10 Jumper location

3.4.2 Factory default setting

Figure 3.11 shows the default setting position at the factory.

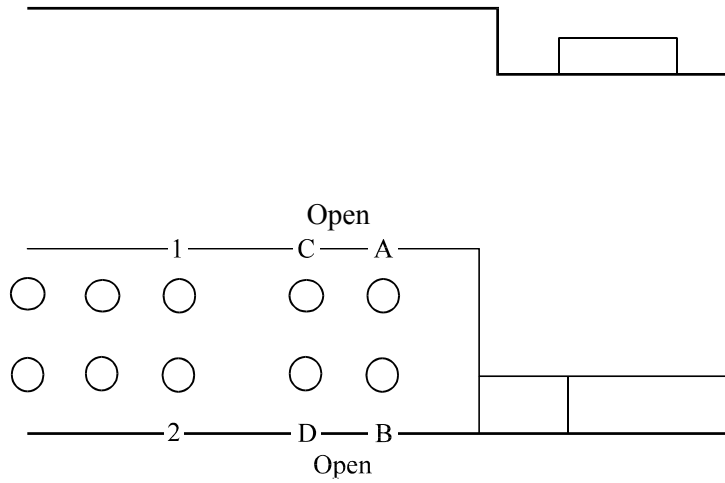

Figure 3.11 Factory default setting

3.4.3 Master drive-slave drive setting

Master drive (disk drive #0) or slave drive (disk drive #1) is selected.

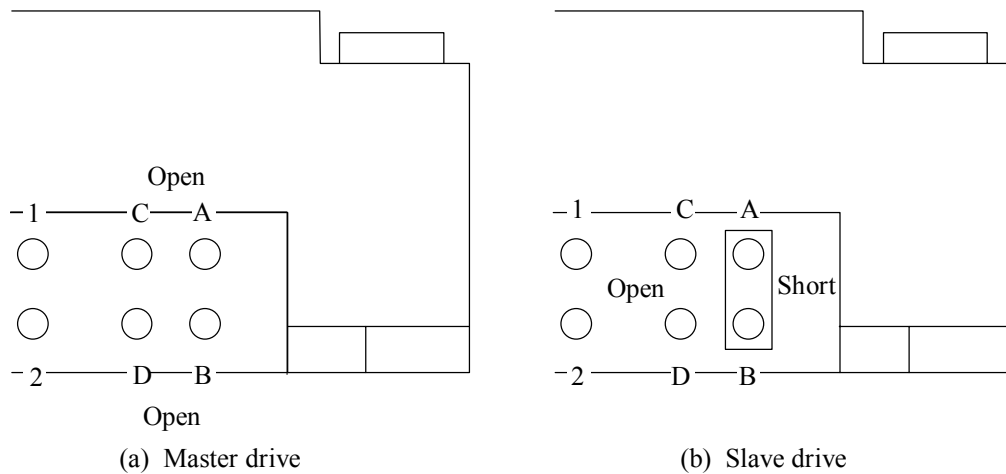

Figure 3.12 Jumper setting of master or slave drive

Note:

Pins A and C should be open.

3.4.4 CSEL setting

Figure 3.13 shows the cable select (CSEL) setting.

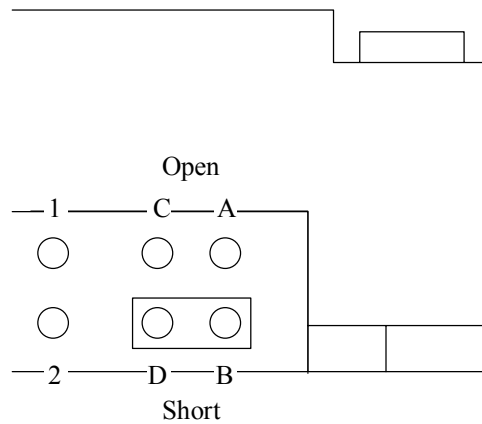

Note:

The CSEL setting is not depended on setting between pins Band D.

Figure 3.13 CSEL setting

Figure 3.14 and 3.15 show examples of cable selection using unique interface cables.

By connecting the CSEL of the master drive to the CSEL Line (conductor) of the cable and connecting it to ground further, the CSEL is set to low level. The drive is identified as a master drive. At this time, the CSEL of the slave drive does not have a conductor. Thus, since the slave drive is not connected to the CSEL conductor, the CSEL is set to high level. The drive is identified as a slave drive.

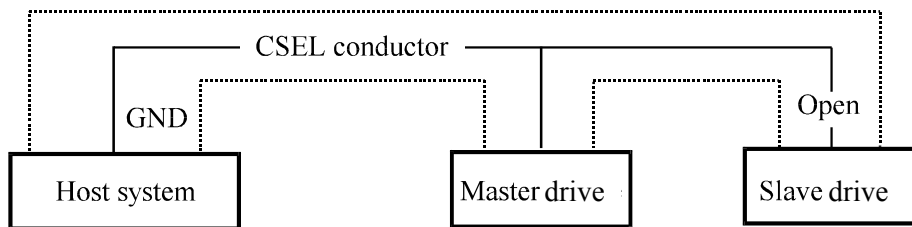

Figure 3.14 Example (1) of cable select

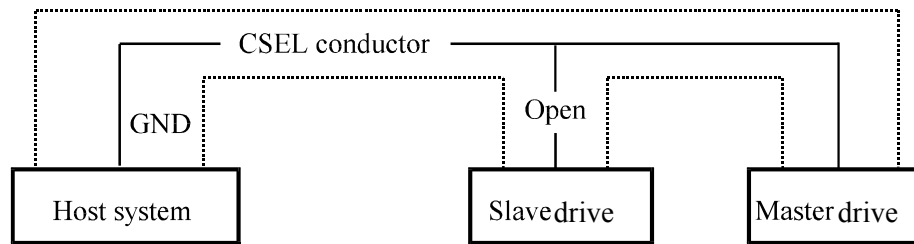

Figure 3.15 Example (2) of cable select

3.4.5 Power up in standby setting

When pin C is grounded, the drive does not spin up at power on.

This page is intentionally left blank.

CHAPTER 4 Theory of Device Operation

- 4.1 Outline
- 4.2 Subassemblies
- 4.3 Circuit Configuration
- 4.4 Power-on Sequence
- 4.5 Self-calibration
- 4.6 Read/write Circuit
- 4.7 Servo Control

This chapter explains basic design concepts of the disk drive. Also, this chapter explains subassemblies of the disk drive, each sequence, servo control, and electrical circuit blocks.

4.1 Outline

This chapter consists of two parts. First part (Section 4.2) explains mechanical assemblies of the disk drive. Second part (Sections 4.3 through 4.7) explains a servo information recorded in the disk drive and drive control method.

4.2 Subassemblies

The disk drive consists of a disk enclosure (DE) and printed circuit assembly (PCA).

The DE contains all movable parts in the disk drive, including the disk, spindle, actuator, read/write head, and air filter. For details, see Subsections 4.2.1 to 4.2.4.

The PCA contains the control circuits for the disk drive. The disk drive has one PCA. For details, see Sections 4.3.

4.2.1 Disk

The DE contains disks with an outer diameter of 65 mm and an inner diameter of 20 mm.

Servo data is recorded on each cylinder (total 172). Servo data written at factory is read out by the read head. For servo data, see Section 4.7.

4.2.2 Spindle

The spindle consists of a disk stack assembly and spindle motor. The disk stack assembly is activated by the direct drive sensor-less DC spindle motor, which has a speed of 4,200 rpm $\pm 1\%$. The spindle is controlled with detecting a PHASE signal generated by counter electromotive voltage of the spindle motor at starting.

4.2.3 Actuator

The actuator consists of a voice coil motor (VCM) and a head carriage. The VCM moves the head carriage along the inner or outer edge of the disk. The head carriage position is controlled by feeding back the difference of the target position that is detected and reproduced from the servo information read by the read/write head.

4.2.4 Air filter

There are two types of air filters: a breather filter and a circulation filter.

The breather filter makes an air in and out of the DE to prevent unnecessary pressure around the spindle when the disk starts or stops rotating. When disk drives are transported under conditions where the air pressure changes a lot, filtered air is circulated in the DE.

The circulation filter cleans out dust and dirt from inside the DE. The disk drive cycles air continuously through the circulation filter through an enclosed loop air cycle system operated by a blower on the rotating disk.

4.3 Circuit Configuration

Figure 4.1 shows the power supply configuration of the disk drive, and Figure 4.2 shows the disk drive circuit configuration.

(1) Read/write circuit

The read/write circuit consists of two circuits; read/write preamplifier (PreAMP) and read channel (RDC).

The PreAMP consists of the write current switch circuit, that flows the write current to the head coil, and the voltage amplifier circuit, that amplifies the read output from the head.

The RDC is the read demodulation circuit using the Modified Extended Partial Response (MEEP), and contains the Viterbi detector, programmable filter, adaptable transversal filter, times base generator, data separator circuits, RLL (Run Length Limited) encoder and servo demodulation circuit.

(2) Servo circuit

The position and speed of the voice coil motor are controlled by closed-loop servo using the servo information recorded on the data surface. The servo information is an analog signal converted to digital for processing by a MPU and then reconverted to an analog signal for control of the voice coil motor.

The MPU precisely sets each head on the track according on the servo information on the media surface.

(3) Spindle motor driver circuit

The circuit measures the interval of a PHASE signal generated by counter-electromotive voltage of a motor and controls the motor speed comparing target speed.

(4) Controller circuit

Major functions are listed below.

- ATA interface control and data transfer control
- Data buffer management
- Sector format control
- Defect management
- ECC control
- Error recovery and self-diagnosis

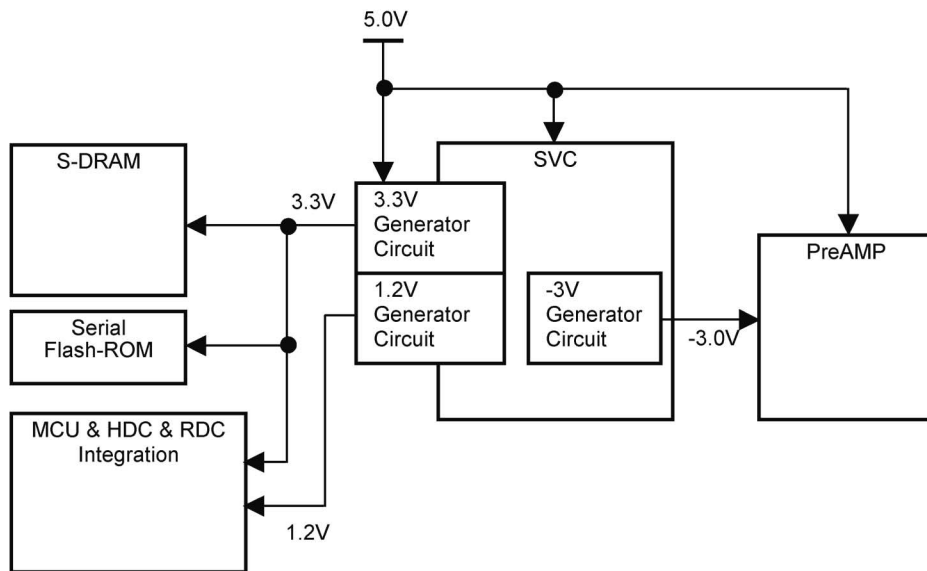

Figure 4.1 Power supply configuration

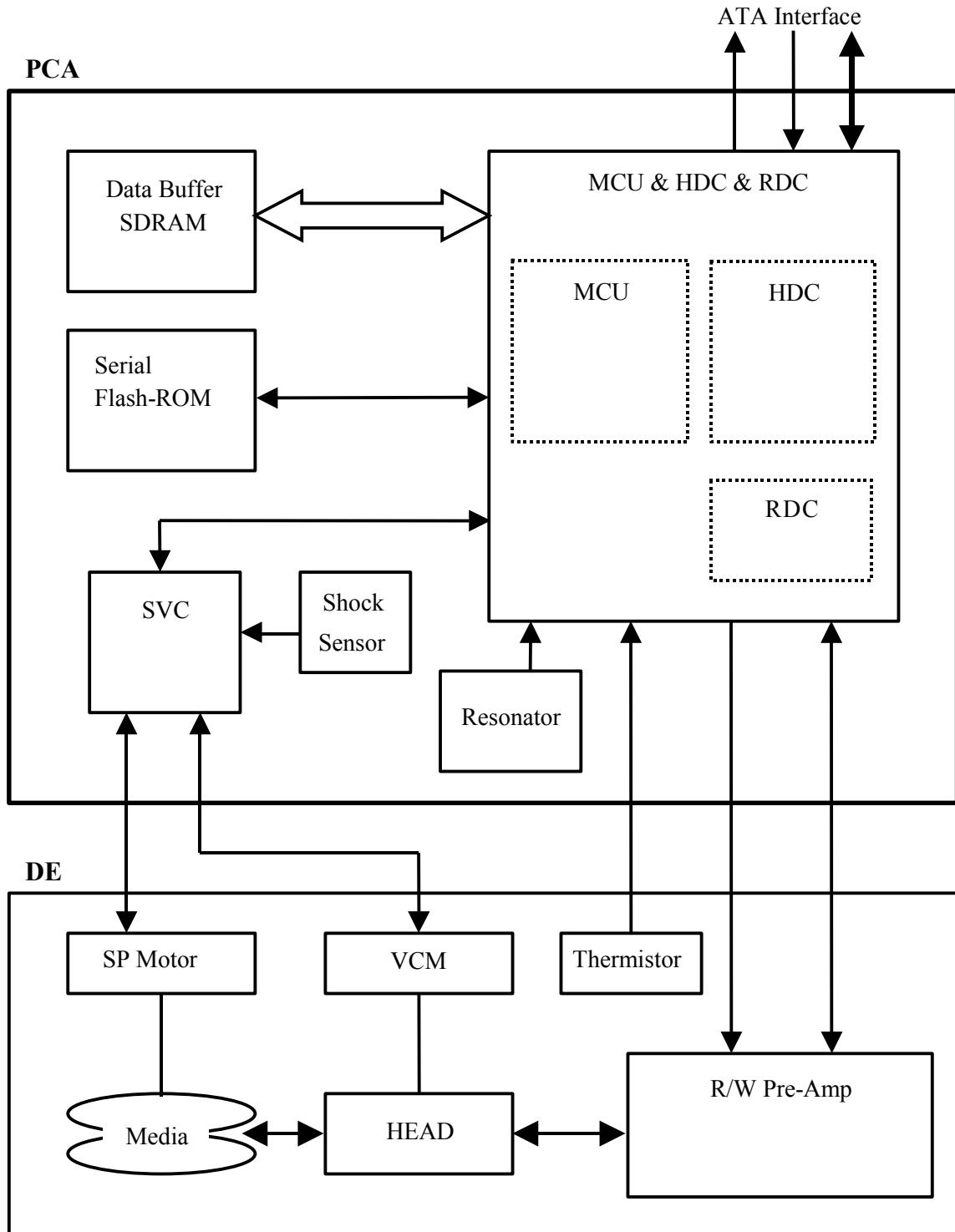
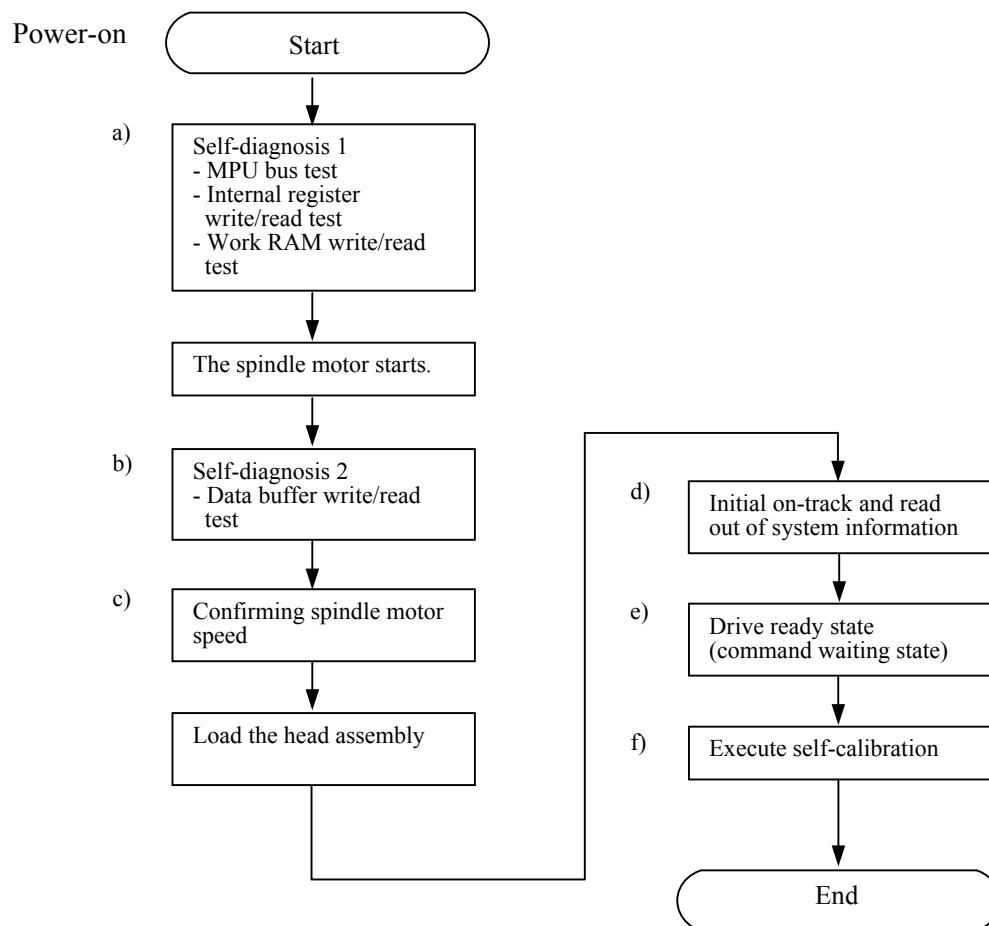

Figure 4.2 Circuit configuration

4.4 Power-on Sequence

Figure 4.3 describes the operation sequence of the disk drive at power-on. The outline is described below.

- a) After the power is turned on, the disk drive executes the MPU bus test, internal register read/write test, and work RAM read/write test. When the self-diagnosis terminates successfully, the disk drive starts the spindle motor.
- b) The disk drive executes self-diagnosis (data buffer read/write test) after enabling response to the ATA bus.
- c) After confirming that the spindle motor has reached rated speed, the head assembly is loaded on the disk.
- d) The disk drive positions the heads onto the SA area and reads out the system information.
- e) The drive becomes ready. The host can issue commands.
- f) The disk drive executes self-calibration. This collects data for VCM torque and mechanical external forces applied to the actuator, and updates the calibrating value.



Figur

e 4.3 Power-on operation sequence

4.5 Self-calibration

The disk drive occasionally performs self-calibration in order to sense and calibrate mechanical external forces on the actuator, and VCM torque. This enables precise seek and read/write operations.

4.5.1 Self-calibration contents

(1) Sensing and compensating for external forces

The actuator suffers from torque due to the FPC forces and winds accompanying disk revolution. The torque varies with the disk drive and the cylinder where the head is positioned. To execute stable fast seek operations, external forces are occasionally sensed.

The firmware of the drive measures and stores the force (value of the actuator motor drive current) that balances the torque for stopping head stably. This includes the current offset in the power amplifier circuit and DAC system.

The forces are compensated by adding the measured value to the specified current value to the power amplifier. This makes the stable servo control.

To compensate torque varying by the cylinder, the disk is divided into 13 areas from the innermost to the outermost circumference and the compensating value is measured at the measuring cylinder on each area at factory calibration. The measured values are stored in the SA cylinder. In the self-calibration, the compensating value is updated using the value in the SA cylinder.

(2) Compensating open loop gain

Torque constant value of the VCM has dispersion for each drive, and varies depending on the cylinder that the head is positioned. To realize the high speed seek operation, the value that compensates torque constant value change and loop gain change of the whole servo system due to temperature change is measured and stored.

For sensing, the firmware mixes the disturbance signal to the position signal at the state that the head is positioned to any cylinder. The firmware calculates the loop gain from the position signal and stores the compensation value against to the target gain as ratio.

For compensating, the direction current value to the power amplifier is multiplied by the compensation value. By this compensation, loop gain becomes constant value and the stable servo control is realized.

To compensate torque constant value change depending on cylinder, whole cylinders from most inner to most outer cylinder are divided into 13 partitions at calibration in the factory, and the compensation data is measured for representative cylinder of each partition. This measured value is stored in the SA area. The compensation value at self-calibration is calculated using the value in the SA area.

4.5.2 Execution timing of self-calibration

Self-calibration is performed once when power is turned on. After that, the disk drive does not perform self-calibration until it detects an error.

That is, self-calibration is performed each time one of the following events occur:

- In the case that the disk drive starts up normally, the first part of self-calibration starts after a lapse of 100 msec. The execution of first part is about 150 msec. length. The remains is executed thereafter the transfer to Active-Idle state which takes about 200 msec. The latter is interrupted when the disk drive receives a Host command, and it resumes after next transfer to Active-Idle state.
- The number of retries to write or seek data reaches the specified value.
- The error rate of data reading, writing, or seeking becomes lower than the specified value.

4.5.3 Command processing during self-calibration

This enables the host to execute the command without waiting for a long time, even when the disk drive is performing self-calibration. The command execution wait time is about maximum 72 ms.

When the error rate of data reading, writing, or seeking becomes lower than the specified value, self-calibration is performed to maintain disk drive stability.

If the disk drive receives a command execution request from the host while performing self-calibration, it stops the self-calibration and starts to execute the command. In other words, if a disk read or write service is necessary, the disk drive positions the head to the track requested by the host, reads or writes data, and then restarts calibration after about 3 seconds.

If the error rate recovers to a value exceeding the specified value, self-calibration is not performed.

4.6 Read/write Circuit

The read/write circuit consists of the read/write preamplifier (PreAMP), the write circuit, the read circuit, and the time base generator in the read channel (RDC). Figure 4.4 is a block diagram of the read/write circuit.

4.6.1 Read/write preamplifier (PreAMP)

PreAMP equips a read preamplifier and a write current switch, that sets the bias current to the MR device and the current in writing. Each channel is connected to each data head, and PreAMP switches channel by serial I/O. In the event of any abnormalities, including a head short-circuit or head open circuit, the write unsafe signal is generated so that abnormal write does not occur.

4.6.2 Write circuit

The write data is output from the hard disk controller (HDC) and sent to the RDC. The write data is sent to the PreAMP as differential signal, and the data is written onto the media.

(1) Write precompensation

Write precompensation compensates, during a write process, for write non-linearity generated at reading.

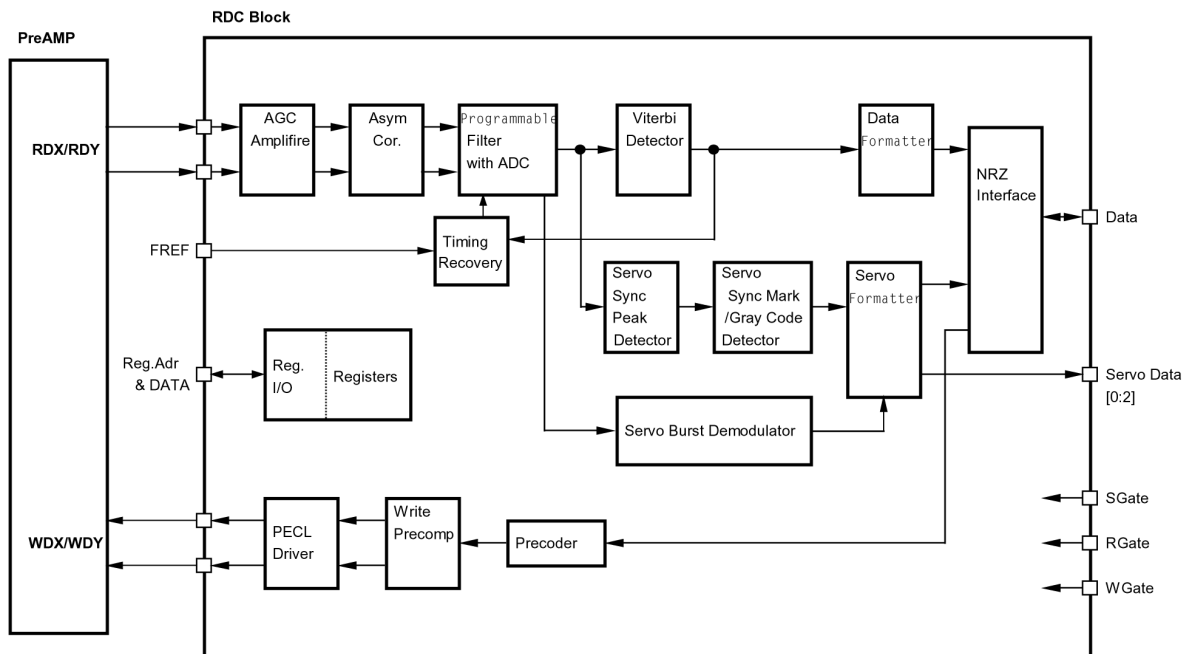

Figure 4.4 Read/write circuit block diagram

4.6.3 Read circuit

The head read signal from the PreAMP is regulated by the automatic gain control (AGC) circuit. Then the output is converted into the sampled read data pulse by the programmable filter circuit and the flash digitizer circuit. This signal is converted into the read data by the ENDEC circuit based on the read data maximum-likelihood-detected by the Viterbi detection circuit.

(1) AGC circuit

The AGC circuit automatically regulates the output amplitude to a constant value even when the input amplitude level fluctuates. The AGC amplifier output is maintained at a constant level even when the head output fluctuates due to the head characteristics or outer/inner head positions.

(2) Programmable filter circuit

The programmable filter circuit has a low-pass filter function that eliminates unnecessary high frequency noise component and a high frequency boost-up function that equalizes the waveform of the read signal.

Cut-off frequency of the low-pass filter and boost-up gain are controlled from the register in read channel block. The MPU optimizes the cut-off frequency and boost-up gain according to the transfer frequency of each zone.

Figure 4.5 shows the frequency characteristic sample of the programmable filter.

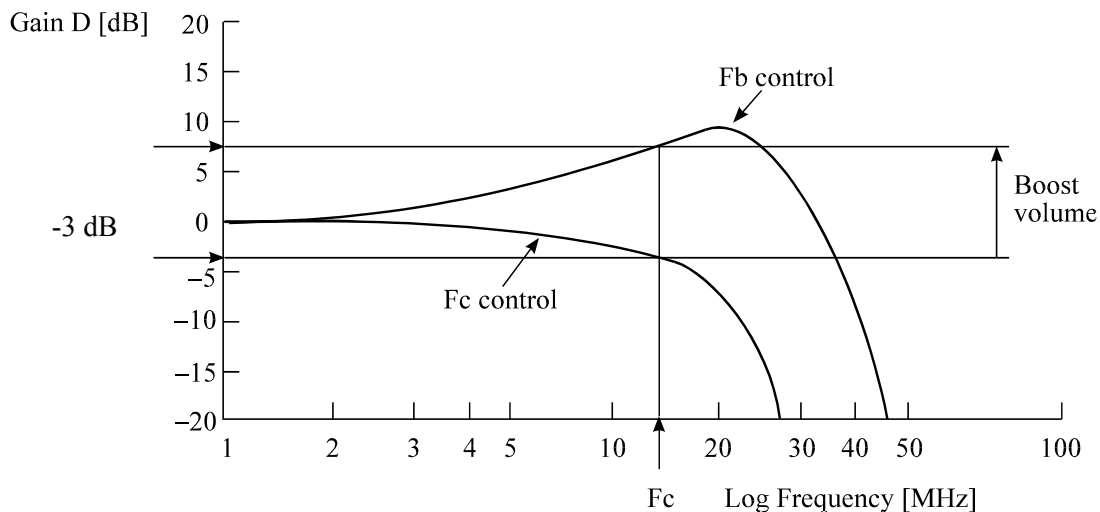

Figure 4.5 Frequency characteristic of programmable filter

(3) FIR circuit

This circuit is 10-tap sampled analog transversal filter circuit that equalizes the head read signal to the Modified Extended Partial Response (MEEPR) waveform.

(4) A/D converter circuit

This circuit changes Sampled Read Data Pulse from the FIR circuit into Digital Read Data.

(5) Viterbi detection circuit

The sample hold waveform output from the flash digitizer circuit is sent to the Viterbi detection circuit. The Viterbi detection circuit demodulates data according to the survivor path sequence.

4.6.4 Digital PLL circuit

The drive uses constant density recording to increase total capacity. This is different from the conventional method of recording data with a fixed data transfer rate at all data area. In the constant density recording method, data area is divided into zones by radius and the data transfer rate is set so that the recording density of the inner cylinder of each zone is nearly constant. The drive divides data area into 30 zones to set the data transfer rate.

The MPU set the data transfer rate setup data (SD/SC) to the RDC that includes the Digital PLL circuit to change the data transfer rate.

4.7 Servo Control

The actuator motor and the spindle motor are submitted to servo control. The actuator motor is controlled for moving and positioning the head to the track containing the desired data. To turn the disk at a constant velocity, the actuator motor is controlled according to the servo data that is written on the data side beforehand.

4.7.1 Servo control circuit

Figure 4.6 is the block diagram of the servo control circuit. The following describes the functions of the blocks:

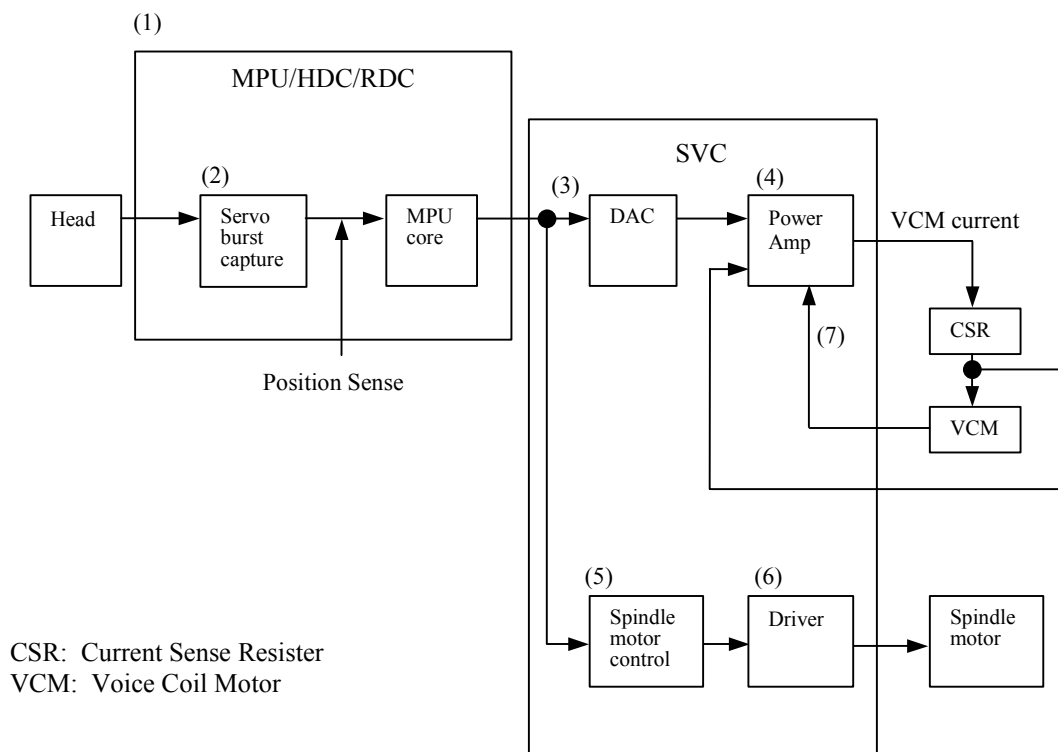

Figure 4.6 Block diagram of servo control circuit

(1) Microprocessor unit (MPU)

The MPU executes startup of the spindle motor, movement to the reference cylinder, seek to the specified cylinder, and calibration operations.

The main internal operations of the MPU are shown below.

a. Spindle motor start

Starts the spindle motor and accelerates it to normal speed when power is applied.

b. Move head to reference cylinder

Drives the VCM to position the head at the any cylinder in the data area. The logical initial cylinder is at the outermost circumference (cylinder 0).

c. Seek to specified cylinder

Drives the VCM to position the head to the specified cylinder.

d. Calibration

Senses and stores the thermal offset between heads and the mechanical forces on the actuator, and stores the calibration value.

(2) Servo burst capture circuit

The servo burst capture circuit reproduces signals (position signals) that indicate the head position from the servo data on the data surface. From the servo area on the data area surface, via the data head, the burst signals of EVEN1, ODD, EVEN2 are output as shown in Figure 4.8 in subsequent to the servo mark, gray code that indicates the cylinder position, and index information. The servo signals do A/D-convert by Fourier-demodulator in the servo burst capture circuit. At that time the AGC circuit is in hold mode. The A/D converted data is recognized by the MPU as position information.

(3) D/A converter (DAC)

The control program calculates the specified data value (digital value) of the VCM drive current, and the value is converted from digital-to-analog so that an analog output voltage is sent to the power amplifier.

(4) Power amplifier

The power amplifier feeds currents, corresponding to the DAC output signal voltage to the VCM.

(5) Spindle motor control circuit

The spindle motor control circuit controls the sensor-less spindle motor. A spindle driver IC with a built-in PLL circuit that is on a hardware unit controls the sensor-less spindle motor.

(6) Driver circuit

The driver circuit is a power amplitude circuit that receives signals from the spindle motor control circuit and feeds currents to the spindle motor.

(7) VCM current sense resistor (CSR)

This resistor controls current at the power amplifier by converting the VCM current into voltage and feeding back.

4.7.2 Data-surface servo format

Figure 4.7 describes the physical layout of the servo frame. The three areas indicated by (1) to (3) in Figure 4.7 are described below.

(1) Inner guard band

This area is located inside the user area, and the rotational speed of the VCM can be controlled on this cylinder area for head moving.

(2) Data area

This area is used as the user data area SA area.

(3) Outer guard band

This area is located at outer position of the user data area, and the rotational speed of the spindle can be controlled on this cylinder area for head moving.

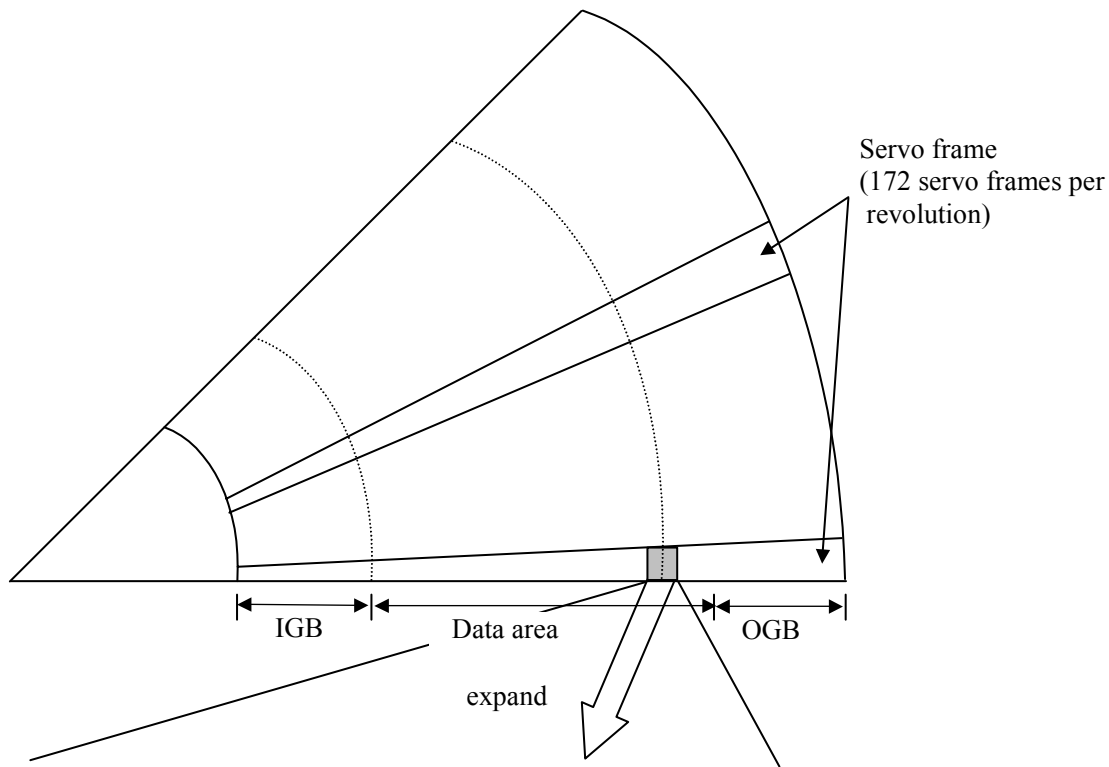

CYLn + 1		CYLn		CYLn - 1 (n: even number)	
W/R Recovery	W/R Recovery	W/R Recovery	W/R Recovery	W/R Recovery	W/R Recovery
Servo Mark	Servo Mark	Servo Mark	Servo Mark	Servo Mark	Servo Mark
Gray Code	Gray Code	Gray Code	Gray Code	Gray Code	Gray Code
EVEN1					
ODD					
EVEN2					
Post code (particular models only)					
PAD					

⇔ Diameter direction
 ↓ Circumference Direction
 Erase: DC erase area

Figure 4.7 Physical sector servo configuration on disk surface

4.7.3 Servo frame format

As the servo information, the IDD uses the phase signal servo generated from the gray code and servo EVEN and ODD. This servo information is used for positioning operation of radius direction and position detection of circumstance direction.

The servo frame consists of 5 blocks; write/read recovery, servo mark, gray code, Burst EVEN1, Burst ODD, Burst EVEN2, and PAD. Figure 4.8 shows the servo frame format.

Write/read recovery	Servo mark	Gray code	Burst EVEN1	Burst ODD	Burst EVEN2	Post code (particular models only)	PAD
---------------------	------------	-----------	-------------	-----------	-------------	------------------------------------	-----

Figure 4.8 Servo frame format

(1) Write/read recovery

This area is used to absorb the write/read transient and to stabilize the AGC.

(2) Servo mark

This area generates a timing for demodulating the gray code and position-demodulating the burst signal by detecting the servo mark.

(3) Gray code (including sector address bits)

This area is used as cylinder address. The data in this area is converted into the binary data by the gray code demodulation circuit

(4) Burst Even1, Burst Odd, Burst Even2

These areas are used as position signals between tracks and the IDD control so that target phase signal is generated from Burst Even and Burst Odd.

(5) Post code (particular models only)

This area is used for the precise correction of the servo information which is recorded on the media.

(6) PAD

This area is used as a gap between servo and data.

4.7.4 Actuator motor control

The voice coil motor (VCM) is controlled by feeding back the servo data recorded on the data surface. The MPU fetches the position sense data on the servo frame at a constant interval of sampling time, executes calculation, and updates the VCM drive current.

The servo control of the actuator includes the operation to move the head to the reference cylinder, the seek operation to move the head to the target cylinder to read or write data, and the track-following operation to position the head onto the target track.

(1) Operation to move the head to the reference cylinder

The MPU moves the head to the reference cylinder when the power is turned. The reference cylinder is in the data area.

When power is applied the heads are moved from the outside of media to the normal servo data zone in the following sequence:

- a) Micro current is fed to the VCM to press the head against the outer direction.
- b) The head is loaded on the disk.
- c) When the servo mark is detected the head is moved slowly toward the inner circumference at a constant speed.
- d) If the head is stopped at the reference cylinder from there. Track following control starts.

(2) Seek operation

Upon a data read/write request from the host, the MPU confirms the necessity of access to the disk. If a read/write instruction is issued, the MPU seeks the desired track.

The MPU feeds the VCM current via the D/A converter and power amplifier to move the head. The MPU calculates the difference (speed error) between the specified target position and the current position for each sampling timing during head moving. The MPU then feeds the VCM drive current by setting the calculated result into the D/A converter. The calculation is digitally executed by the firmware. When the head arrives at the target cylinder, the track is followed.

(3) Track following operation

Except during head movement to the reference cylinder and seek operation under the spindle rotates in steady speed, the MPU does track following control. To position the head at the center of a track, the DSP drives the VCM by feeding micro current. For each sampling time, the VCM drive current is determined by filtering the position difference between the target position and the position clarified by the detected position sense data. The filtering includes servo compensation. These are digitally controlled by the firmware.

4.7.5 Spindle motor control

Hall-less three-phase twelve-pole motor is used for the spindle motor, and the 3-phase full/half-wave analog current control circuit is used as the spindle motor driver (called SVC hereafter). The firmware operates on the MPU manufactured by Fujitsu. The spindle motor is controlled by sending several signals from the MPU to the SVC. There are three modes for the spindle control; start mode, acceleration mode, and stable rotation mode.

(1) Start mode

When power is supplied, the spindle motor is started in the following sequence:

- a) After the power is turned on, the MPU sends a signal to the SVC to charge the charge pump capacitor of the SVC. The charged amount defines the current that flows in the spindle motor.
- b) When the charge pump capacitor is charged enough, the MPU sets the SVC to the motor start mode. Then, a current (approx. 0.3 A) flows into the spindle motor.
It moves to c) or e) step depending on the condition of spindle motor. It is treated as the stop condition, it moves to the step c). Whereas, it is treated as the free-wheeling condition, it moves to the step e).
- c) The phase of the current flowed in the motor is changed in the order of (V-phase to U-phase), (W-phase to U-phase), (W-phase to V-phase), (U-phase to V-phase), (U-phase to W-phase), and (V-phase to W-phase) (after that, repeating this order).
The above operations mean the generation of rotational magnetic field.
- d) During phase switching, the spindle motor starts rotating in low speed, and generates a back electromotive force. The SVC detects this back electromotive force and reports to the MPU using a PHASE signal for speed detection.
- e) The MPU is waiting for a PHASE signal. When no phase signal is sent for a specific period, the MPU resets the SVC and starts from the beginning. When a PHASE signal is sent, the SVC enters the acceleration mode.

(2) Acceleration mode

In this mode, the MPU stops the phase switching to the SVC. The SVC starts a phase switching by itself based on the back electromotive force. Then, rotation of the spindle motor accelerates. The MPU calculates a rotational speed of the spindle motor based on the PHASE signal from the SVC, and waits till the rotational speed reaches 4,200 rpm. When the rotational speed reaches 4,200 rpm, the SVC enters the stable rotation mode.

(3) Stable rotation mode

The SVC builds the PLL circuit into, and to become the rotational speed of the target, controls a stable rotation with hardware.

The firmware calculates time of one rotation from PHASE signal. PHASE signal is outputted from the SVC. And the firmware observes an abnormal rotation.

This page is intentionally left blank.

CHAPTER 5 Interface

- 5.1 Physical Interface
- 5.2 Logical Interface
- 5.3 Host Commands
- 5.4 Command Protocol
- 5.5 Ultra DMA Feature Set
- 5.6 Timing

This chapter gives details about the interface, and the interface commands and timings.

5.1 Physical Interface

5.1.1 Interface signals

Figure 5.1 shows the interface signals.

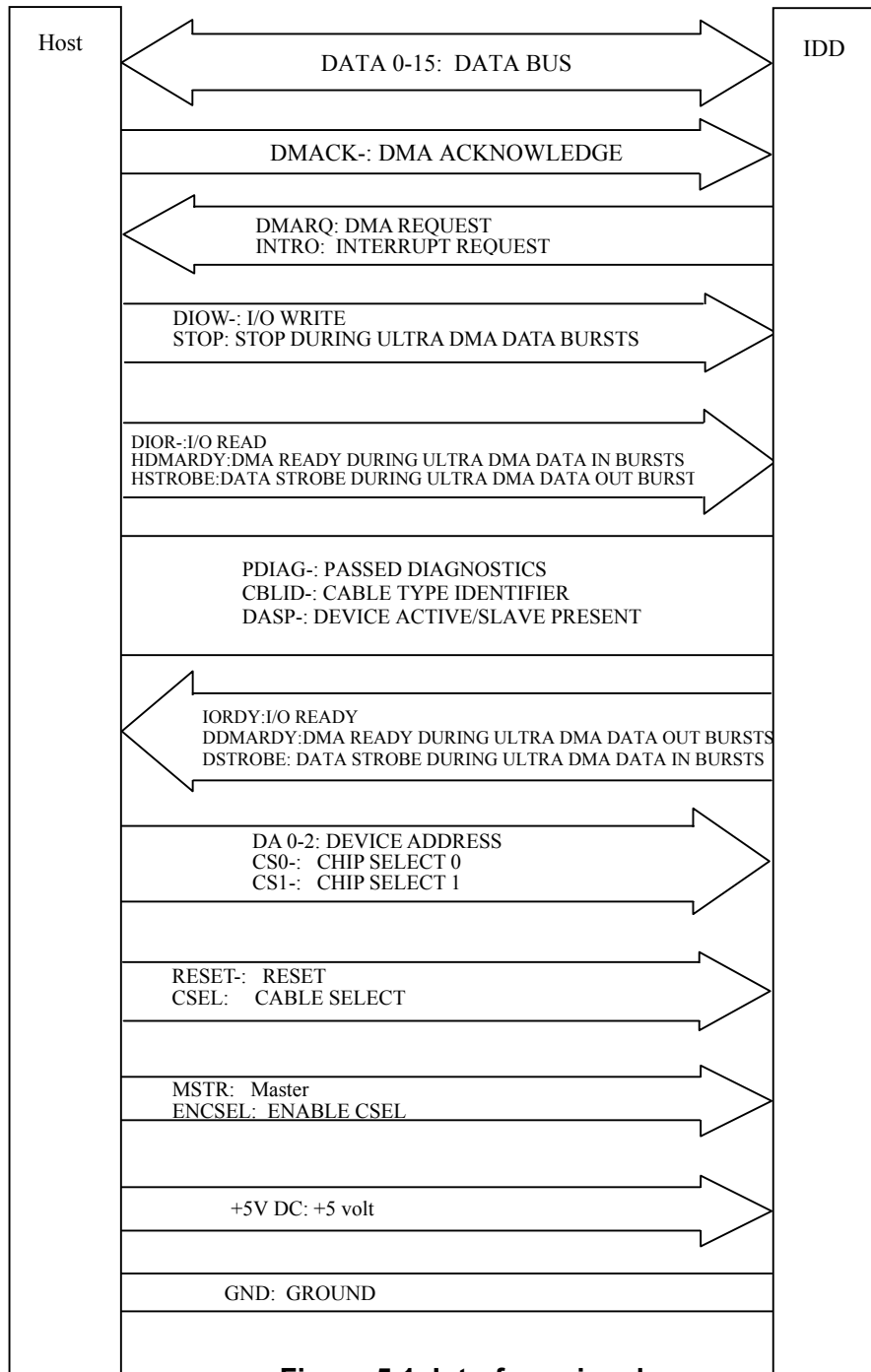

Figure 5.1 Interface signals

5.1.2 Signal assignment on the connector

Table 5.1 shows the signal assignment on the interface connector.

Table 5.1 Signal assignment on the interface connector

Pin No.	Signal	Pin No.	Signal
A	MSTR	B	MSTR/ENCSEL
C	PUS-	D	ENCSEL
E	(KEY)	F	(KEY)
1	RESET-	2	GND
3	DATA7	4	DATA8
5	DATA6	6	DATA9
7	DATA5	8	DATA10
9	DATA4	10	DATA11
11	DATA3	12	DATA12
13	DATA2	14	DATA13
15	DATA1	16	DATA14
17	DATA0	18	DATA15
19	GND	20	(KEY)
21	DMARQ	22	GND
23	DIOW-, STOP	24	GND
25	DIOR-, HDMRDY, HSTROBE	26	GND
27	IORDY, DDMARDY, DSTROBE	28	CSEL
29	DMACK-	30	GND
31	INTRQ	32	Reserved (IOCS16-)
33	DA1	34	PDIAG-, CBLID-
35	DA0	36	DA2
37	CS0-	38	CS1-
39	DASP-	40	GND
41	+5 VDC	42	+5 VDC
43	GND	44	Unused

[Signal]	[I/O]	[Description]
ENCSEL	I	This signal is used to set master/slave using the CSEL signal (pin 28). Pins B and D Open: Sets master/slave using the CSEL signal is disabled. Short: Sets master/slave using the CSEL signal is enabled.
MSTR-	I	MSTR, I, Master/slave setting Pin A, B, C, D open: Master setting Pin A, B Short: Slave setting
PUS-	I	When pin C is grounded, the drive does not spin up at power on.
RESET-	I	Reset signal from the host. This signal is low active and is asserted for a minimum of 25 μ s during power on.
DATA 0-15	I/O	Sixteen-bit bi-directional data bus between the host and the device. These signals are used for data transfer.
DIOW-	I	Signal asserted by the host to write to the device register or data port.
STOP	I	DIOW- must be negated by the host before starting the Ultra DMA transfer. The STOP signal must be negated by the host before data is transferred during the Ultra DMA transfer. During data transfer in Ultra DMA mode, the assertion of the STOP signal asserted by the host later indicates that the transfer has been suspended.
DIOR-	I	Read strobe signal from the host to read the device register or data port
HDMARDY-	I	Flow control signal for Ultra DMA data In transfer (READ DMA command). This signal is asserted by the host to inform the device that the host is ready to receive the Ultra DMA data In transfer. The host can negate the HDMARDY- signal to suspend the Ultra DMA data In transfer.
HSTROBE	I	Data Out Strobe signal from the host during Ultra DMA data Out transfer (WRITE DMA command). Both the rising and falling edges of the HSTROBE signal latch data from Data 15-0 into the device. The host can suspend the inversion of the HSTROBE signal to suspend the Ultra DMA data Out transfer.
INTRQ	O	Interrupt signal to the host. This signal is negated in the following cases: <ul style="list-style-type: none"> - Assertion of RESET- signal - Reset by SRST of the Device Control register - Write to the command register by the host - Read of the status register by the host - Completion of sector data transfer (without reading the Status register) The signal output line has a high impedance when no devices are selected or interruption is disabled.

[Signal]	[I/O]	[Description]
----------	-------	---------------

[Signal]	[I/O]	[Description]
CS0-	I	Chip select signal decoded from the host address bus. This signal is used by the host to select the command block registers.
CS1-	I	Chip select signal decoded from the host address bus. This signal is used by the host to select the control block registers.
DA 0-2	I	Binary decoded address signals asserted by the host to access task file registers.
KEY	-	Key pin for prevention of erroneous connector insertion
PDIAG-	I/O	This signal is an input mode for the master device and an output mode for the slave device in a daisy chain configuration. This signal indicates that the slave device has been completed self-diagnostics. This signal is pulled up to +5 V through 10 kΩ resistor at each device.
CBLID-	I/O	This signal is used to detect the type of cable installed in the system. This signal is pulled up to +5 V through 10 kΩ resistor at each device.
DASP-	I/O	This is a time-multiplexed signal that indicates that the device is active and a slave device is present. This signal is pulled up to +5 V through 10 kΩ resistor at each device.
IORDY	O	This signal requests the host system to delay the transfer cycle when the device is not ready to respond to a data transfer request from the host system.
DDMARDY-	O	Flow control signal for Ultra DMA data Out transfer (WRITE DMA command). This signal is asserted by the device to inform the host that the device is ready to receive the Ultra DMA data Out transfer. The device can negate the DDMARDY- signal to suspend the Ultra DMA data Out transfer.
DSTROBE	O	Data In Strobe signal from the device during Ultra DMA data In transfer. Both the rising and falling edges of the DSTROBE signal latch data from Data 15-0 into the host. The device can suspend the inversion of the DSTROBE signal to suspend the Ultra DMA data In transfer.
CSEL	I	This signal to configure the device as a master or a slave device. <ul style="list-style-type: none"> - When CSEL signal is grounded, the IDD is a master device. - When CSEL signal is open, the IDD is a slave device. This signal is pulled up with 240 kΩ resistor at each device.
DMACK-	I	The host system asserts this signal as a response that the host system receives data or to indicate that data is valid.

[Signal]	[I/O]	[Description]
DMARQ	O	<p>This signal is used for DMA transfer between the host system and the device. The device asserts this signal when the device completes the preparation of DMA data transfer to the host system (at reading) or from the host system (at writing).</p> <p>The direction of data transfer is controlled by the DIOR and DIOW signals. This signal hand shakes with the DMACK-signal. In other words, the device negates the DMARQ signal after the host system asserts the DMACK signal. When there is other data to be transferred, the device asserts the DMARQ signal again.</p> <p>When the DMA data transfer is performed, IOCS16-, CS0- and CS1- signals are not asserted. The DMA data transfer is a 16-bit data transfer.</p>
+5 VDC	I	+5 VDC power supplying to the device.
GND	-	Grounded signal at each signal wire.

Note:

“I” indicates input signal from the host to the device.

“O” indicates output signal from the device to the host.

“I/O” indicates common output or bi-directional signal between the host and the device.

5.2 Logical Interface

The device can operate for command execution in either address-specified mode; cylinder-head-sector (CHS) or Logical block address (LBA) mode. The IDENTIFY DEVICE information indicates whether the device supports the LBA mode. When the host system specifies the LBA mode by setting bit 6 in the Device/Head register to 1, HS3 to HS0 bits of the Device/Head register indicates the head No. under the LBA mode, and all bits of the Cylinder High, Cylinder Low, and Sector Number registers are LBA bits.

The sector No. under the LBA mode proceeds in the ascending order with the start point of LBA0 (defined as follows).

LBA0 = [Cylinder 0, Head 0, Sector 1]

Even if the host system changes the assignment of the CHS mode by the INITIALIZE DEVICE PARAMETER command, the sector LBA address is not changed.

$$\text{LBA} = [((\text{Cylinder No.}) \times (\text{Number of head}) + (\text{Head No.})) \times (\text{Number of sector/track})] + (\text{Sector No.}) - 1$$

5.2.1 I/O registers

Communication between the host system and the device is done through input-output (I/O) registers of the device.

These I/O registers can be selected by the coded signals, CS0-, CS1-, and DA0 to DA2 from the host system. Table 5.2 shows the coding address and the function of I/O registers.

Table 5.2 I/O registers

CS0-	CS1-	DA2	DA1	DA0	I/O registers		Host I/O address
					Read operation	Write operation	
Command block registers							
L	H	L	L	L	Data	Data	X'1F0'
L	H	L	L	H	Error Register	Features	X'1F1'
L	H	L	H	L	Sector Count	Sector Count	X'1F2'
L	H	L	H	H	Sector Number	Sector Number	X'1F3'
L	H	H	L	L	Cylinder Low	Cylinder Low	X'1F4'
L	H	H	L	H	Cylinder High	Cylinder High	X'1F5'
L	H	H	H	L	Device/Head	Device/Head	X'1F6'
L	H	H	H	H	Status	Command	X'1F7'
L	L	X	X	X	(Invalid)	(Invalid)	—
Control block registers							
H	L	H	H	L	Alternate Status	Device Control	X'3F6'
H	L	H	H	H	—	—	X'3F7'

Notes:

1. The Data register for read or write operation can be accessed by 16 bit data bus (DATA0 to DATA15).
2. The registers for read or write operation other than the Data registers can be accessed by 8 bit data bus (DATA0 to DATA7).
3. When reading the Drive Address register, bit 7 is high-impedance state.
4. H indicates signal level High and L indicates signal level Low.

There are two methods for specifying the LBA mode. One method is to specify the LBA mode with 28-bit address information, and the other is to specify it with 48-bit address information (command of EXT system). If the LBA mode is specified with 28-bit address information, the Device/Head,

Cylinder High, Cylinder Low, Sector Number registers indicate LBA bits 27 to 24, bits 23 to 16, bits 15 to 8, and bits 7 to 0, respectively.

If the LBA mode is specified with 48-bit address information, the Cylinder High, Cylinder Low, Sector Number registers are set twice. In the first time, the registers indicate LBA bits 47 to 40, bits 39 to 32, and bits 31 to 24, respectively. In the second time, the registers indicate LBA bits 23 to 16, bits 15 to 8, and bits 7 to 0, respectively.

5.2.2 Command block registers

(1) Data register (X'1F0')

The Data register is a 16-bit register for data block transfer between the device and the host system. Data transfer mode is PIO or DMA mode.

(2) Error register (X'1F1')

The Error register indicates the status of the command executed by the device. The contents of this register are valid when the ERR bit of the Status register is 1.

This register contains a diagnostic code after power is turned on, a reset, or the EXECUTIVE DEVICE DIAGNOSTIC command is executed.

[Status at the completion of command execution other than diagnostic command]

Bit 7	Bit 6	Bit 5	Bit 4	Bit 3	Bit 2	Bit 1	Bit 0
ICRC	UNC	X	IDNF	X	ABRT	TK0NF	AMNF

X: Unused

- Bit 7: Interface CRC Error (ICRC). This bit indicates that a CRC error occurred during Ultra DMA transfer.
- Bit 6: Uncorrectable Data Error (UNC). This bit indicates that an uncorrectable data error has been encountered.
- Bit 5: Unused
- Bit 4: ID Not Found (IDNF). This bit indicates an error except for bad sector, uncorrectable error and SB not found.
- Bit 3: Unused
- Bit 2: Aborted Command (ABRT). This bit indicates that the requested command was aborted due to a device status error (e.g. Not Ready, Write Fault) or the command code was invalid.

- Bit 1: Track 0 Not Found (TK0NF). This bit indicates that track 0 was not found during RECALIBRATE command execution.
- Bit 0: Address Mark Not Found (AMNF). This bit indicates that the SB Not Found error occurred.

[Diagnostic code]

- X'01': No Error Detected.
- X'02': HDC Diagnostic Error
- X'03': Data Buffer Diagnostic Error.
- X'04': Memory Diagnostic Error.
- X'05': Reading the system area is abnormal.
- X'06': Calibration is abnormal.
- X'80': Device 1 (slave device) Failed.

Error register of the master device is valid under two devices (master and slave) configuration. If the slave device fails, the master device posts X'80' OR (the diagnostic code) with its own status (X'01' to X'06').

However, when the host system selects the slave device, the diagnostic code of the slave device is posted.

(3) Features register (X'1F1')

The Features register provides specific feature to a command. For instance, it is used with SET FEATURES command to enable or disable caching.

(4) Sector Count register (X'1F2')

The Sector Count register indicates the number of sectors of data to be transferred in a read or write operation between the host system and the device. When the value in this register is X'00', the sector count is 256. With the EXT system command, the sector count is 65536 when value of this register is X'00' in the first setting and X'00' in the second setting.

When this register indicates X'00' at the completion of the command execution, this indicates that the command is completed successfully. If the command is not completed successfully, this register indicates the number of sectors to be transferred to complete the request from the host system. That is, this register indicates the number of remaining sectors that the data has not been transferred due to the error.

The contents of this register have other definition for the following commands; INITIALIZE DEVICE PARAMETERS, SET FEATURES, IDLE, STANDBY and SET MULTIPLE MODE.

(5) Sector Number register (X'1F3')

The contents of this register indicate the starting sector number for the subsequent command. The sector number should be between X'01' and [the number of sectors per track defined by INITIALIZE DEVICE PARAMETERS command.

Under the LBA mode, this register indicates LBA bits 7 to 0.

Under the LBA mode of the EXT system command, LBA bits 31 to 24 are set in the first setting, and LBA bits 7 to 0 are set in the second setting.

(6) Cylinder Low register (X'1F4')

The contents of this register indicate low-order 8 bits of the starting cylinder address for any disk-access.

At the end of a command, the contents of this register are updated to the current cylinder number.

Under the LBA mode, this register indicates LBA bits 15 to 8.

Under the LBA mode of the EXT system command, LBA bits 39 to 32 are set in the first setting, and LBA bits 15 to 8 are set in the second setting.

(7) Cylinder High register (X'1F5')

The contents of this register indicate high-order 8 bits of the disk-access start cylinder address.

At the end of a command, the contents of this register are updated to the current cylinder number. The high-order 8 bits of the cylinder address are set to the Cylinder High register.

Under the LBA mode, this register indicates LBA bits 23 to 16.

Under the LBA mode of the EXT system command, LBA bits 47 to 40 are set in the first setting, and LBA bits 23 to 16 are set in the second setting.

(8) Device/Head register (X'1F6')

The contents of this register indicate the device and the head number.

When executing INITIALIZE DEVICE PARAMETERS command, the contents of this register defines “the number of heads minus 1” (a maximum head No.).

Bit 7	Bit 6	Bit 5	Bit 4	Bit 3	Bit 2	Bit 1	Bit 0
X	L	X	DEV	HS3	HS2	HS1	HS0

- Bit 7: Unused
- Bit 6: L. 0 for CHS mode and 1 for LBA mode.
- Bit 5: Unused
- Bit 4: DEV bit. 0 for the master device and 1 for the slave device.
- Bit 3: HS3 CHS mode head address 3 (2^3). bit 27 for LBA mode. Unused under the LBA mode of the EXT command.
- Bit 2: HS2 CHS mode head address 2 (2^2). bit 26 for LBA mode. Unused under the LBA mode of the EXT command.
- Bit 1: HS1 CHS mode head address 1 (2^1). bit 25 for LBA mode. Unused under the LBA mode of the EXT command.
- Bit 0: HS0 CHS mode head address 0 (2^0). bit 24 for LBA mode. Unused under the LBA mode of the EXT command.

(9) Status register (X'1F7')

The contents of this register indicate the status of the device. The contents of this register are updated at the completion of each command. When the BSY bit is cleared, other bits in this register should be validated within 400 ns. When the BSY bit is 1, other bits of this register are invalid. When the host system reads this register while an interrupt is pending, it is considered to be the Interrupt Acknowledge (the host system acknowledges the interrupt). Any pending interrupt is cleared (negating INTRQ signal) whenever this register is read.

Bit 7	Bit 6	Bit 5	Bit 4	Bit 3	Bit 2	Bit 1	Bit 0
BSY	DRDY	DF	DSC	DRQ	0	0	ERR

- Bit 7: Busy (BSY) bit. This bit is set whenever the Command register is accessed. Then this bit is cleared when the command is completed. However, even if a command is being executed, this bit is 0 while data transfer is being requested (DRQ bit = 1). When BSY bit is 1, the host system should not write the command block registers. If the host system reads any command block register when BSY bit is 1, the contents of the Status register are posted. This bit is set by the device under following conditions:
 - (a) Within 400 ns after RESET- is negated or SRST is set in the Device Control register, the BSY bit is set. The BSY bit is cleared, when the reset process is completed.
The BSY bit is set for no longer than 15 seconds after the IDD accepts reset.
 - (b) Within 400 ns from the host system starts writing to the Command register.
 - (c) Within 5 μ s following transfer of 512 bytes data during execution of the READ SECTOR(S), WRITE SECTOR(S), or WRITE BUFFER command.
- Bit 6: Device Ready (DRDY) bit. This bit indicates that the device is capable to respond to a command.
The IDD checks its status when it receives a command. If an error is detected (not ready state), the IDD clears this bit to 0. This is cleared to 0 at power-on and it is cleared until the rotational speed of the spindle motor reaches the steady speed.
- Bit 5: The Device Write Fault (DF) bit. This bit indicates that a device fault (write fault) condition has been detected.
If a write fault is detected during command execution, this bit is latched and retained until the device accepts the next command or reset.
- Bit 4: Device Seek Complete (DSC) bit. This bit indicates that the device heads are positioned over a track.
In the IDD, this bit is always set to 1 after the spin-up control is completed.
- Bit 3: Data Request (DRQ) bit. This bit indicates that the device is ready to transfer data of word unit or byte unit between the host system and the device.
- Bit 2: Always 0.
- Bit 1: Always 0.
- Bit 0: Error (ERR) bit. This bit indicates that an error was detected while the previous command was being executed. The Error register indicates the additional information of the cause for the error.

(10) Command register (X'1F7')

The Command register contains a command code being sent to the device. After this register is written, the command execution starts immediately.

Table 5.3 lists the executable commands and their command codes. This table also lists the necessary parameters for each command which are written to certain registers before the Command register is written.

5.2.3 Control block registers**(1) Alternate Status register (X'3F6')**

The Alternate Status register contains the same information as the Status register of the command block register.

The only difference from the Status register is that a read of this register does not imply Interrupt Acknowledge and INTRQ signal is not reset.

Bit 7	Bit 6	Bit 5	Bit 4	Bit 3	Bit 2	Bit 1	Bit 0
BSY	DRDY	DF	DSC	DRQ	0	0	ERR

(2) Device Control register (X'3F6')

The Device Control register contains device interrupt and software reset.

Bit 7	Bit 6	Bit 5	Bit 4	Bit 3	Bit 2	Bit 1	Bit 0
HOB	X	X	X	X	SRST	nIEN	0

- Bit 7: High Order Byte (HOB) is the selector bit that selects higher-order information or lower-order information of the EXT system command.
If HOB = 1, LBA bits 47 to 24 and the higher-order 8 bits of the sector count are displayed in the task register.
If HOB = 0, LBA bits 23 to 0 and the lower-order 8 bits of the sector count are displayed in the task register.
- Bit 2: Software Reset (SRST) is the host software reset bit. When this bit is set, the device is held reset state. When two devices are daisy chained on the interface, setting this bit resets both devices simultaneously.
The slave device is not required to execute the DASP- handshake.
- Bit 1: nIEN bit enables an interrupt (INTRQ signal) from the device to the host. When this bit is 0 and the device is selected, an interruption (INTRQ signal) can be enabled through a tri-state buffer. When this bit is 1 or the device is not selected, the INTRQ signal is in the high-impedance state.

5.3 Host Commands

The host system issues a command to the device by writing necessary parameters in related registers in the command block and writing a command code in the Command register.

The device can accept the command when the BSY bit is 0 (the device is not in the busy status).

The host system can halt the uncompleted command execution only at execution of hardware or software reset.

When the BSY bit is 1 or the DRQ bit is 1 (the device is requesting the data transfer) and the host system writes to the command register, the correct device operation is not guaranteed.

5.3.1 Command code and parameters

Table 5.3 lists the supported commands, command code and the registers that needed parameters are written.

Table 5.3 Command code and parameters (1 of 2)

COMMAND NAME	COMMAND CODE (Bit)								PARAMETER USED				
	7	6	5	4	3	2	1	0	FR	SC	SN	CY	DH
RECALIBRATE	0	0	0	1	X	X	X	X	N	N	N	N	D
READ SECTOR(S)	0	0	1	0	0	0	0	R	N	Y	Y	Y	Y
WRITE SECTOR(S)	0	0	1	1	0	0	0	R	N	Y	Y	Y	Y
WRITE VERIFY	0	0	1	1	1	1	0	0	N	Y	Y	Y	Y
READ VERIFY SECTOR(S)	0	1	0	0	0	0	0	R	N	Y	Y	Y	Y
SEEK	0	1	1	1	X	X	X	X	N	N	Y	Y	Y
EXECUTE DEVICE DIAGNOSTIC	1	0	0	1	0	0	0	0	N	N	N	N	D*
INITIALIZE DEVICE PARAMETERS	1	0	0	1	0	0	0	1	N	Y	N	N	Y
DOWNLOAD MICROCODE	1	0	0	1	0	0	1	0	Y	Y	Y	N	D
STANDBY IMMEDIATE	1 1	0 1	0 1	1 0	0 0	1 0	0 0	0 0	N	N	N	N	D
IDLE IMMEDIATE	1 1	0 1	0 1	1 0	0 0	1 0	0 0	1 1	N	N	N	N	D
UNLOAD IMMEDIATE	1 1	0 1	0 1	1 0	0 0	1 0	0 0	1 1	Y	N	Y	Y	D
STANDBY	1 1	0 1	0 1	1 0	0 0	1 0	1 1	0 0	N	Y	N	N	D
IDLE	1 1	0 1	0 1	1 0	0 0	1 0	1 1	1 1	N	Y	N	N	D
CHECK POWER MODE	1 1	0 1	0 1	1 0	1 0	0 1	0 0	0 1	N	N	N	N	D
SLEEP	1 1	0 1	0 1	1 0	1 0	0 1	0 1	1 0	N	N	N	N	D
SMART	1	0	1	1	0	0	0	0	Y	Y	Y	Y	D
DEVICE CONFIGURATION	1	0	1	1	0	0	0	1	Y	N	N	N	D
READ MULTIPLE	1	1	0	0	0	1	0	0	N	Y	Y	Y	Y
WRITE MULTIPLE	1	1	0	0	0	1	0	1	N	Y	Y	Y	Y
SET MULTIPLE MODE	1	1	0	0	0	1	1	0	N	Y	N	N	D
READ DMA	1	1	0	0	1	0	0	R	N	Y	Y	Y	Y
WRITE DMA	1	1	0	0	1	0	1	R	N	Y	Y	Y	Y
READ BUFFER	1	1	1	0	0	1	0	0	N	N	N	N	D

Table 5.3 Command code and parameters (2 of 2)

COMMAND NAME	COMMAND CODE (Bit)								PARAMETER USED				
	7	6	5	4	3	2	1	0	FR	SC	SN	CY	DH
FLUSH CACHE	1	1	1	0	0	1	1	1	N	N	N	N	D
WRITE BUFFER	1	1	1	0	1	0	0	0	N	N	N	N	D
IDENTIFY DEVICE	1	1	1	0	1	1	0	0	N	N	N	N	D
IDENTIFY DEVICE DMA	1	1	1	0	1	1	0	0	N	N	N	N	D
SET FEATURES	1	1	1	0	1	1	1	1	Y	N*	N	N	D
SECURITY SET PASSWORD	1	1	1	1	0	0	0	1	N	N	N	N	D
SECURITY UNLOCK	1	1	1	1	0	0	1	0	N	N	N	N	D
SECURITY ERASE PREPARE	1	1	1	1	0	0	1	1	N	N	N	N	D
SECURITY ERASE UNIT	1	1	1	1	0	1	0	0	N	N	N	N	D
SECURITY FREEZE LOCK	1	1	1	1	0	1	0	1	N	N	N	N	D
SECURITY DISABLE PASSWORD	1	1	1	1	0	1	1	0	N	N	N	N	D
READ NATIVE MAX ADDRESS	1	1	1	1	1	0	0	0	N	N	N	N	D
SET MAX	1	1	1	1	1	0	0	1	Y	Y	Y	Y	Y
READ SECTOR(S) EXT *O	0	0	1	0	0	1	0	0	N	Y	Y	Y	D
READ DMA EXT *O	0	0	1	0	0	1	0	1	N	Y	Y	Y	D
READ NATIVE MAX ADDRESS EXT *O	1	1	1	1	1	0	0	0	N	N	N	N	D
READ MULTIPLE EXT *O	0	0	1	0	1	0	0	1	N	Y	Y	Y	D
READ LOG EXT *O	0	0	1	0	1	1	1	1	N	Y	Y	Y	D
WRITE SECTOR(S) EXT *O	0	0	1	1	0	1	0	0	N	Y	Y	Y	D
WRITE DMA EXT *O	0	0	1	1	0	1	0	1	N	Y	Y	Y	D
SET MAX ADDRESS EXT *O	0	0	1	1	0	1	1	1	N	Y	Y	Y	Y
WRITE MULTIPLE EXT *O	0	0	1	1	1	0	0	1	N	Y	Y	Y	D
WRITE DMA FUA EXT *O	0	0	1	1	1	1	0	1	N	Y	Y	Y	D
WRITE LOG EXT *O	0	0	1	1	1	1	1	1	N	Y	Y	Y	D
READ VERIFY SECTOR(S) EXT *O	0	1	0	0	0	0	1	0	N	Y	Y	Y	D
WRITE MULTIPLE FUA EXT *O	1	1	0	0	1	1	1	0	N	Y	Y	Y	D
FLUSH CACHE EXT *O	1	1	1	0	1	0	1	0	N	N	N	N	D

Note: READ LONG (0x22) command/WRITE LONG (0x33) command became a unsupported from the MHW2xxxAT series.

Notes:

FR: Features Register

CY: Cylinder Registers

SC: Sector Count Register

DH: Drive/Head Register

SN: Sector Number Register

R: Retry at error

1 = Without retry

0 = With retry

Y: Necessary to set parameters

Y*: Necessary to set parameters under the LBA mode.

N: Not necessary to set parameters (The parameter is ignored if it is set.)

N*: May set parameters

D: The device parameter is valid, and the head parameter is ignored.

*O: Option (customizing)

D*: The command is addressed to the master device, but both the master device and the slave device execute it.

X: Do not care

5.3.2 Command descriptions

The contents of the I/O registers to be necessary for issuing a command and the example indication of the I/O registers at command completion are shown as following in this subsection.

Example: READ SECTOR(S)

At command issuance (I/O registers setting contents)								
Bit	7	6	5	4	3	2	1	0
1F7 _H (CM)	0	0	1	0	0	0	0	0
1F6 _H (DH)	x	L	x	DV	Head No. / LBA [MSB]			
1F5 _H (CH)	Start cylinder address [MSB] / LBA							
1F4 _H (CL)	Start cylinder address [LSB] / LBA							
1F3 _H (SN)	Start sector No. / LBA [LSB]							
1F2 _H (SC)	Transfer sector count							
1F1 _H (FR)	xx							

At command completion (I/O registers contents to be read)								
Bit	7	6	5	4	3	2	1	0
1F7 _H (ST)	Status information							
1F6 _H (DH)	x	L	x	DV	Head No. / LBA [MSB]			
1F5 _H (CH)	End cylinder address [MSB] / LBA							
1F4 _H (CL)	End cylinder address [LSB] / LBA							
1F3 _H (SN)	End sector No. / LBA [LSB]							
1F2 _H (SC)	X'00'							
1F1 _H (ER)	Error information							

CM: Command register FR: Features register

DH: Device/Head register ST: Status register

CH: Cylinder High register ER: Error register

CL: Cylinder Low register L: LBA (logical block address) setting bit

SN: Sector Number register DV: Device address. bit

SC: Sector Count register x, xx: Do not care (no necessary to set)

Note:

1. When the L bit is specified to 1, the lower 4 bits of the DH register and all bits of the CH, CL and SN registers indicate the LBA bits (bits of the DH register are the MSB (most significant bit) and bits of the SN register are the LSB (least significant bit)).
2. At error occurrence, the SC register indicates the remaining sector count of data transfer.
3. In the table indicating I/O registers contents in this subsection, bit indication is omitted.

(1) RECALIBRATE (X'10' to X'1F')

This command performs the calibration. Upon receipt of this command, the device sets BSY bit of the Status register and performs a calibration. When the device completes the calibration, the device updates the Status register, clears the BSY bit, and generates an interrupt.

This command can be issued in the LBA mode.

At command issuance (I/O registers setting contents)							
1F7 _H (CM)	0	0	0	1	x	x	x
1F6 _H (DH)	x	x	x	DV	xx		
1F5 _H (CH)	xx						
1F4 _H (CL)	xx						
1F3 _H (SN)	xx						
1F2 _H (SC)	xx						
1F1 _H (FR)	xx						

At command completion (I/O registers contents to be read)							
1F7 _H (ST)	Status information						
1F6 _H (DH)	x	x	x	DV	xx		
1F5 _H (CH)	xx						
1F4 _H (CL)	xx						
1F3 _H (SN)	xx						
1F2 _H (SC)	xx						
1F1 _H (ER)	Error information						

Note:

Also executable in LBA mode.

(2) READ SECTOR(S) (X'20' or X'21')

This command reads data of sectors specified in the Sector Count register from the address specified in the Device/Head, Cylinder High, Cylinder Low and Sector Number registers. Number of sectors can be specified from 1 to 256 sectors. To specify 256 sectors reading, '00' is specified. For the DRQ, INTRQ, and BSY protocols related to data transfer, see Subsection 5.4.1.

If the head is not on the track specified by the host, the device performs an implied seek. After the head reaches to the specified track, the device reads the target sector.

If an error occurs, retry reads are attempted to read the target sector before reporting an error, irrespective of the R bit setting.

The DRQ bit of the Status register is always set prior to the data transfer regardless of an error condition.

Upon the completion of the command execution, command block registers contain the cylinder, head, and sector addresses (in the CHS mode) or logical block address (in the LBA mode) of the last sector read.

If an unrecoverable error occurs in a sector, the read operation is terminated at the sector where the error occurred. Command block registers contain the cylinder, the head, and the sector addresses of the sector (in the CHS mode) or the logical block address (in the LBA mode) where the error occurred, and remaining number of sectors of which data was not transferred.

At command issuance (I/O registers setting contents)							
1F7 _H (CM)	0	0	1	0	0	0	R
1F6 _H (DH)	x	L	x	DV	Start head No. / LBA [MSB]		
1F5 _H (CH)	Start cylinder No. [MSB] / LBA						
1F4 _H (CL)	Start cylinder No. [LSB] / LBA						
1F3 _H (SN)	Start sector No. / LBA [LSB]						
1F2 _H (SC)	Transfer sector count						
1F1 _H (FR)	xx						

(R: Retry)

At command completion (I/O registers contents to be read)					
1F7 _H (ST)	Status information				
1F6 _H (DH)	x	L	x	DV	End head No. / LBA [MSB]
1F5 _H (CH)	End cylinder No. [MSB] / LBA				
1F4 _H (CL)	End cylinder No. [LSB] / LBA				
1F3 _H (SN)	End sector No. / LBA [LSB]				
1F2 _H (SC)	00 (*1)				
1F1 _H (ER)	Error information				

*1 If the command is terminated due to an error, the remaining number of sectors of which data was not transferred is set in this register.

(3) WRITE SECTOR(S) (X'30' or X'31')

This command writes data of sectors from the address specified in the Device/Head, Cylinder High, Cylinder Low, and Sector Number registers to the address specified in the Sector Count register. Number of sectors can be specified from 1 to 256 sectors. A sector count of 0 requests 256 sectors. Data transfer begins at the sector specified in the Sector Number register. For the DRQ, INTRQ, and BSY protocols related to data transfer, see Subsection 5.4.2.

If the head is not on the track specified by the host, the device performs an implied seek. After the head reaches to the specified track, the device writes the target sector.

If an error occurs when writing to the target sector, retries are attempted irrespectively of the R bit setting.

The data stored in the buffer, and CRC code and ECC bytes are written to the data field of the corresponding sector(s). Upon the completion of the command execution, the command block registers contain the cylinder, head, and sector addresses of the last sector written.

If an error occurs during multiple sector write operation, the write operation is terminated at the sector where the error occurred. Command block registers contain the cylinder, the head, the sector addresses (in the CHS mode) or the logical block address (in the LBA mode) of the sector where the error occurred.

At command issuance (I/O registers setting contents)							
1F7 _H (CM)	0	0	1	1	0	0	0 R
1F6 _H (DH)	x	L	x	DV	Start head No. / LBA [MSB]		
1F5 _H (CH)	Start cylinder No. [MSB] / LBA						
1F4 _H (CL)	Start cylinder No. [LSB] / LBA						
1F3 _H (SN)	Start sector No. / LBA [LSB]						
1F2 _H (SC)	Transfer sector count						
1F1 _H (FR)	xx						

At command completion (I/O registers contents to be read)					
1F7 _H (ST)	Status information				
1F6 _H (DH)	x	L	x	DV	End head No./LBA [MSB]
1F5 _H (CH)	End cylinder No. [MSB] / LBA				
1F4 _H (CL)	End cylinder No. [LSB] / LBA				
1F3 _H (SN)	End sector No. / LBA [LSB]				
1F2 _H (SC)	00 (*1)				
1F1 _H (ER)	Error information				

- *1 If the command is terminated due to an error, the remaining number of sectors of which data was not transferred is set in this register.

(4) WRITE VERIFY (X'3C')

This command operates similarly to the WRITE SECTOR(S) command except that the device verifies each sector immediately after being written. The verify operation is a read and check for data errors without data transfer. Any error that is detected during the verify operation is posted.

After all sectors are verified, the last interruption (INTRQ for command termination) is generated.

At command issuance (I/O registers setting contents)					
1F7 _H (CM)	0	0	1	1	1 1 0 0
1F6 _H (DH)	x	L	x	DV	Start head No. / LBA [MSB]
1F5 _H (CH)	Start cylinder No. [MSB] / LBA				
1F4 _H (CL)	Start cylinder No. [LSB] / LBA				
1F3 _H (SN)	Start sector No. / LBA [LSB]				
1F2 _H (SC)	Transfer sector count				
1F1 _H (FR)	xx				

At command completion (I/O registers contents to be read)					
1F7 _H (ST)	Status information				
1F6 _H (DH)	x	L	x	DV	End head No. / LBA [MSB]
1F5 _H (CH)	End cylinder No. [MSB] / LBA				
1F4 _H (CL)	End cylinder No. [LSB] / LBA				
1F3 _H (SN)	End sector No. / LBA [LSB]				
1F2 _H (SC)	00 (*1)				
1F1 _H (ER)	Error information				

*1 If the command is terminated due to an error, the remaining number of sectors of which data was not transferred is set in this register.

(5) READ VERIFY SECTOR(S) (X'40' or X'41')

This command operates similarly to the READ SECTOR(S) command except that the data is not transferred to the host system.

After all requested sectors are verified, the device clears the BSY bit of the Status register and generates an interrupt. Upon the completion of the command execution, the command block registers contain the cylinder, head, and sector number of the last sector verified.

If an unrecoverable error occurs, the verify operation is terminated at the sector where the error occurred. The command block registers contain the cylinder, the head, and the sector addresses (in the CHS mode) or the logical block address (in the LBA mode) of the sector where the error occurred. The Sector Count register indicates the number of sectors that have not been verified.

At command issuance (I/O registers setting contents)					
1F7 _H (CM)	0	1	0	0	0 0 0 R
1F6 _H (DH)	x	L	x	DV	Start head No. / LBA [MSB]
1F5 _H (CH)	Start cylinder No. [MSB] / LBA				
1F4 _H (CL)	Start cylinder No. [LSB] / LBA				
1F3 _H (SN)	Start sector No. / LBA [LSB]				
1F2 _H (SC)	Transfer sector count				
1F1 _H (FR)	xx				

At command completion (I/O registers contents to be read)					
1F7 _H (ST)	Status information				
1F6 _H (DH)	x	L	x	DV	End head No. / LBA [MSB]
1F5 _H (CH)	End cylinder No. [MSB] / LBA				
1F4 _H (CL)	End cylinder No. [LSB] / LBA				
1F3 _H (SN)	End sector No. / LBA [LSB]				
1F2 _H (SC)	00 (*1)				
1F1 _H (ER)	Error information				

*1 If the command is terminated due to an error, the remaining number of sectors of which data was not transferred is set in this register.

(6) SEEK (X'70' to X'7F')

This command performs a seek operation to the track and selects the head specified in the command block registers. After completing the seek operation, the device clears the BSY bit in the Status register and generates an interrupt.

In the LBA mode, this command performs the seek operation to the cylinder and head position in which the sector is specified with the logical block address.

At command issuance (I/O registers setting contents)							
1F7 _H (CM)	0	1	1	1	x	x	x
1F6 _H (DH)	x	L	x	DV	Head No. / LBA [MSB]		
1F5 _H (CH)	Cylinder No. [MSB] / LBA						
1F4 _H (CL)	Cylinder No. [LSB] / LBA						
1F3 _H (SN)	Sector No. / LBA [LSB]						
1F2 _H (SC)	xx						
1F1 _H (FR)	xx						

At command completion (I/O registers contents to be read)							
1F7 _H (ST)	Status information						
1F6 _H (DH)	x	L	x	DV	Head No. / LBA [MSB]		
1F5 _H (CH)	Cylinder No. [MSB] / LBA						
1F4 _H (CL)	Cylinder No. [LSB] / LBA						
1F3 _H (SN)	Sector No. / LBA [LSB]						
1F2 _H (SC)	xx						
1F1 _H (ER)	Error information						

(7) EXECUTE DEVICE DIAGNOSTIC (X'90')

This command performs an internal diagnostic test (self-diagnosis) of the device. This command usually sets the DRV bit of the Drive/Head register is to 0 (however, the DV bit is not checked). If two devices are present, both devices execute self-diagnosis.

If device 1 is present:

- Both devices shall execute self-diagnosis.
- The device 0 waits for up to 6 seconds until device 1 asserts the PDIAG-signal.
- If the device 1 does not assert the PDIAG- signal but indicates an error, the device 0 shall append X'80' to its own diagnostic status.
- The device 0 clears the BSY bit of the Status register and generates an interrupt. (The device 1 does not generate an interrupt.)
- A diagnostic status of the device 0 is read by the host system. When a diagnostic failure of the device 1 is detected, the host system can read a status of the device 1 by setting the DV bit (selecting the device 1).

When device 1 is not present:

- The device 0 posts only the results of its own self-diagnosis.
- The device 0 clears the BSY bit of the Status register, and generates an interrupt.

Table 5.4 lists the diagnostic code written in the Error register which is 8-bit code.

If the device 1 fails the self-diagnosis, the device 0 “ORs” X'80' with its own status and sets that code to the Error register.

Table 5.4 Diagnostic code

Code	Result of diagnostic
X'01'	No error detected.
X'02'	HDC diagnostic error
X'03'	Data buffer diagnostic error
X'04'	Memory diagnostic error
X'05'	Reading the system area is abnormal
X'06'	Calibration abnormal
X'8x'	Failure of device 1

Note: The device responds to this command with the result of power-on diagnostic test.

At command issuance (I/O registers setting contents)					
1F7 _H (CM)	1	0	0	1	0 0 0 0
1F6 _H (DH)	x	x	x	DV	Head No. /LBA [MSB]
1F5 _H (CH)	xx				
1F4 _H (CL)	xx				
1F3 _H (SN)	xx				
1F2 _H (SC)	xx				
1F1 _H (FR)	xx				

At command completion (I/O registers contents to be read)					
1F7 _H (ST)	Status information				
1F6 _H (DH)	x	x	x	DV	Head No. /LBA [MSB]
1F5 _H (CH)	xx				
1F4 _H (CL)	xx				
1F3 _H (SN)	01 _H				
1F2 _H (SC)	01 _H				
1F1 _H (ER)	Diagnostic code				

(8) INITIALIZE DEVICE PARAMETERS (X'91')

The host system can set the number of sectors per track and the maximum head number (maximum head number is “number of heads minus 1”) per cylinder with this command. Upon receipt of this command, the device sets the BSY bit of Status register and saves the parameters. Then the device clears the BSY bit and generates an interrupt.

When the SC register is specified to X'00', an ABORTED COMMAND error is posted. Other than X'00' is specified, this command terminates normally.

The parameters set by this command are retained even after reset or power save operation regardless of the setting of disabling the reverting to default setting.

The device ignores the L bit specification and operates with only CHS mode specification.

At command issuance (I/O registers setting contents)								
1F7 _H (CM)	1	0	0	1	0	0	0	1
1F6 _H (DH)	x	x	x	DV	Max. head No.			
1F5 _H (CH)	xx							
1F4 _H (CL)	xx							
1F3 _H (SN)	xx							
1F2 _H (SC)	Number of sectors/track							
1F1 _H (FR)	xx							

At command completion (I/O registers contents to be read)						
1F7 _H (ST)	Status information					
1F6 _H (DH)	x	x	x	DV	Max. head No.	
1F5 _H (CH)	xx					
1F4 _H (CL)	xx					
1F3 _H (SN)	xx					
1F2 _H (SC)	Number of sectors/track					
1F1 _H (ER)	Error information					

(9) DOWNLOAD MICROCODE (X'92')

At command issuance (I/O registers setting contents)								
1F7 _h (CM)	1	0	0	1	0	0	1	0
1F6 _h (DH)	1	X	1	DV	0	0	0	0
1F5 _h (CH)	00							
1F4 _h (CL)	00							
1F3 _h (SN)	Sector count (15-8)							
1F2 _h (SC)	Sector count (7-0)							
1F1 _h (FR)	Subcommand code							

At command completion (I/O registers contents to be read)								
1F7 _h (ST)	Status information							
1F6 _h (DH)	1	X	1	DV	0	0	0	0
1F5 _h (CH)	00							
1F4 _h (CL)	00							
1F3 _h (SN)	XX							
1F2 _h (SC)	XX							
1F1 _h (ER)	Error information							

This command rewrites the microcode of the device (firmware).

When this command is accepted, the device does beginning the data transfer of the microcode or the microcode rewriting according to Subcommand code (Rewriting is also possible simultaneously with the data transfer). Refer to Table 5-5.

In the data transfer of Subcommand code:01h, transfer by which data is divided into multiple times is possible. Refer to Table 5-6.

After the designation of rewriting by Subcommand code:07h, reactivates in the device for the update of the rewriting microcode of the microcode.

Table 5.5 Operation of DOWNLOAD MICROCODE

Host Command		Movement of device	
Subcommand code (FR Reg)	Sector count (SN, SC Reg)	Data transfer	Microcode rewriting execution
01h	0000h	Non	Rewriting execution reservation
	xxxxh	It is.	Rewriting execution reservation
07h	0000h	Non	Execution. **
	xxxxh	It is.	Execution. **
Excluding 01h and 07h	–	Abort	

** : In the following cases, Subcommand code=07h returns Abort as an error though becomes Microcode rewriting execution specification.

- 1) Abnormality of the transmitted Microcode data is detected.
- 2) The data transfer is not done (The number of transfer: 0).
- 3) "DOWNLOAD MICROCODE" The command is not continuously issued.

Table 5.6 Example of rewriting procedure of data 512 KBytes (40000h Bytes) of microcode

Transfer example 1: 1) CMD = 92h SN, SC = 0100h FR = 01h 2) CMD = 92h SN, SC = 0100h FR = 01h 3) CMD = 92h SN, SC = 0100h FR = 01h 4) CMD = 92h SN, SC = 0100h FR = 01h 5) CMD = 92h SN, SC = 0000h FR = 07h	Transfer from 0 to 127 KB Transfer from 128 to 255 KB Transfer from 256 to 383 KB Transfer from 384 to 511 KB Firmware rewriting execution
Transfer example 2: 1) CMD = 92h SN, SC = 0400h FR = 01h 2) CMD = 92h SN, SC = 0000h FR = 07h	Transfer of 512 KB Firmware rewriting execution
Transfer example 3: 1) CMD = 92h SN, SC = 0400h FR = 07h	Transfer of 512 KB and Firmware rewriting execution
Transfer example 4: 1) CMD = 92h SN, SC = 0100h FR = 01h 2) CMD = 92h SN, SC = 0100h FR = 01h 3) CMD = 92h SN, SC = 0100h FR = 01h 4) CMD = 92h SN, SC = 0100h FR = 07h	Transfer from 0 to 127 KB Transfer from 128 to 255 KB Transfer from 256 to 383 KB Transfer from 384 to 511 KB and Firmware rewriting execution

When the data of the transfer microcode did the rewriting specification with the illegality and the data transfer not done or the DOWNLOAD MICROCODE command is not continuously issued, reports on the Aborted Command error.

(10) STANDBY IMMEDIATE (X'94' or X'E0')

Upon receipt of this command, the device sets the BSY bit of the Status register and enters the standby mode. The device then clears the BSY bit and generates an interrupt. This command does not support the APS timer function.

At command issuance (I/O registers setting contents)					
1F7 _H (CM)	X'94' or X'E0'				
1F6 _H (DH)	x	x	x	DV	xx
1F5 _H (CH)	xx				
1F4 _H (CL)	xx				
1F3 _H (SN)	xx				
1F2 _H (SC)	xx				
1F1 _H (FR)	xx				

At command completion (I/O registers contents to be read)					
1F7 _H (ST)	Status information				
1F6 _H (DH)	x	x	x	DV	xx
1F5 _H (CH)	xx				
1F4 _H (CL)	xx				
1F3 _H (SN)	xx				
1F2 _H (SC)	xx				
1F1 _H (ER)	Error information				

(11) IDLE IMMEDIATE (X'95' or X'E1') / UNLOAD IMMEDIATE (X'95' or X'E1')

- **Default function**

Upon receipt of this command, the device sets the BSY bit of the Status register, and enters the idle mode. Then, the device clears the BSY bit, and generates an interrupt. This command does not support the APS timer function.

At command issuance (I/O registers setting contents)					
1F7 _H (CM)	X'95' or X'E1'				
1F6 _H (DH)	x	x	x	DV	xx
1F5 _H (CH)	xx				
1F4 _H (CL)	xx				
1F3 _H (SN)	xx				
1F2 _H (SC)	xx				
1F1 _H (FR)	xx				

At command completion (I/O registers contents to be read)					
1F7 _H (ST)	Status information				
1F6 _H (DH)	x	x	x	DV	xx
1F5 _H (CH)	xx				
1F4 _H (CL)	xx				
1F3 _H (SN)	xx				
1F2 _H (SC)	xx				
1F1 _H (ER)	Error information				

- **Unload Feature:**

When the device received the IDLE IMMEDIATE command with the UNLOAD FEATURE, the head(s) is unloaded to the ramp position. After the device completed the unload operation, the INTRQ signal will be asserted and the BUSY flag will be cleared. The time until the head(s) unload to the ramp position is typically less than 500 milliseconds. This unload operation is not same as the power management operation. The device just unloads the head(s), and not executes the power consumption restraint operation. This unload operation effects the normal (not emergency) load/unload guarantee count per the device life.

Even if the device executes reading look-ahead operation or executes writing operation, the device unloads the head(s) to the ramp position as soon as possible when received the IDLE IMMEDIATE command with the Unload Feature. When the writing operation is stopped, the device keeps the unwritten data. And, the device keeps the unloaded state until receiving a Soft / Hard Reset, or a new command except IDLE IMMEDIATE command with the Unload Feature.

At command issuance (I/O registers setting contents)					
1F7 _H (CM)	X'E1'				
1F6 _H (DH)	x	x	x	DV	xx
1F5 _H (CH)	X'55'				
1F4 _H (CL)	X'4E'				
1F3 _H (SN)	X'4C'				
1F2 _H (SC)	xx				
1F1 _H (FR)	X'44'				

At command completion (I/O registers contents to be read)					
1F7 _H (ST)	Status information				
1F6 _H (DH)	x	x	x	DV	xx
1F5 _H (CH)	xx				
1F4 _H (CL)	xx				
1F3 _H (SN)	X'C4'				
1F2 _H (SC)	xx				
1F1 _H (ER)	Error information				

(12) STANDBY (X'96' or X'E2')

Upon receipt of this command, the device sets the BSY bit of the Status register and enters the standby mode. The device then clears the BSY bit and generates an interrupt. If the device has already spun down, the spin-down sequence is not implemented.

Also, by using this command, the device sets the APS (Automatic Power Standby) timer function. If the value of the Sector Count register when this command was received is not '0' then the APS timer value corresponding to it is set, and APS timer function become valid. If the values of the Sector Count register when this command was received is '0' then the APS timer function become invalid.

If the APS timer function becomes valid, then the APS timer begins counting down after completing the next media access command such as the READ or the WRITE. If the device has not received any command during specified period, then the device enters standby mode automatically.

Under the standby mode, the spindle motor is stopped. Thus, when the command involving a seek such as READ SECTOR(s) command is received, the device processes the command after driving the spindle motor.

At command issuance (I/O registers setting contents)					
1F7 _H (CM)	X'96' or X'E2'				
1F6 _H (DH)	x	x	x	DV	xx
1F5 _H (CH)	xx				
1F4 _H (CL)	xx				
1F3 _H (SN)	xx				
1F2 _H (SC)	Period of timer				
1F1 _H (FR)	xx				

At command completion (I/O registers contents to be read)					
1F7 _H (ST)	Status information				
1F6 _H (DH)	x	x	x	DV	xx
1F5 _H (CH)	xx				
1F4 _H (CL)	xx				
1F3 _H (SN)	xx				
1F2 _H (SC)	xx				
1F1 _H (ER)	Error information				

(13) IDLE (X'97' or X'E3')

Upon receipt of this command, the device sets the BSY bit of the Status register, and enters the idle mode. Then, the device clears the BSY bit, and generates an interrupt. The device generates interrupt even if the device has not fully entered the idle mode. If the spindle of the device is already rotating, the spin-up sequence shall not be implemented.

By using this command, the APS (Automatic Power Standby) timer function is enabled and the timer immediately starts the countdown. When the timer reaches the specified value, the device enters standby mode. The APS timer is set to prohibition if the Sector Count register's value was "00h" when device has received this command.

The APS timer allows the device to change to the standby mode automatically after specified period. When the device enters the state which is waiting Host Command, the timer starts countdown. If any command is not issued while the timer is counting down, the device automatically enters the standby mode. If any command is issued while the timer is counting down, the timer is initialized and the command is executed. The timer restarts countdown after completion of the command execution.

The period of timer count is set depending on the value of the Sector Count register as shown below.

Sector Count register value	Point of timer
0 [X'00']	Timeout disabled
1 to 240 [X'01' to X'F0']	(Value × 5) seconds
241 to 251 [X'F1' to X'FB']	((Value-240) × 30) min
252 [X'FC']	21 minutes
253 [X'FD']	8 hrs
254 to 255 [X'FE' to X'FF']	21 minutes 15 seconds

At command issuance (I/O registers setting contents)					
1F7 _H (CM)	X'97' or X'E3'				
1F6 _H (DH)	x	x	x	DV	xx
1F5 _H (CH)	xx				
1F4 _H (CL)	xx				
1F3 _H (SN)	xx				
1F2 _H (SC)	Period of timer				
1F1 _H (FR)	xx				

At command completion (I/O registers contents to be read)					
1F7 _H (ST)	Status information				
1F6 _H (DH)	x	x	x	DV	xx
1F5 _H (CH)	xx				
1F4 _H (CL)	xx				
1F3 _H (SN)	xx				
1F2 _H (SC)	xx				
1F1 _H (ER)	Error information				

(14) CHECK POWER MODE (X'98' or X'E5')

The host checks the power mode of the device with this command.

The host system can confirm the power save mode of the device by the contents of the Sector Count register.

The device sets the BSY bit and sets the following register value. After that, the device clears the BSY bit and generates an interrupt.

Power save mode	Sector Count register
<ul style="list-style-type: none"> • During moving to Standby mode • Standby mode 	X'00'
<ul style="list-style-type: none"> • Idle mode 	X'FF'
<ul style="list-style-type: none"> • Active mode 	X'FF'

At command issuance (I/O registers setting contents)					
1F7 _H (CM)	X'98' or X'E5'				
1F6 _H (DH)	x	x	x	DV	xx
1F5 _H (CH)	xx				
1F4 _H (CL)	xx				
1F3 _H (SN)	xx				
1F2 _H (SC)	xx				
1F1 _H (FR)	xx				

At command completion (I/O registers contents to be read)					
1F7 _H (ST)	Status information				
1F6 _H (DH)	x	x	x	DV	xx
1F5 _H (CH)	xx				
1F4 _H (CL)	xx				
1F3 _H (SN)	xx				
1F2 _H (SC)	X'00' or X'FF'				
1F1 _H (ER)	Error information				

(15) SLEEP (X'99' or X'E6')

This command is the only way to make the device enter the sleep mode.

Upon receipt of this command, the device sets the BSY bit of the Status register and enters the sleep mode. The device then clears the BSY bit and generates an interrupt. The device generates an interrupt even if the device has not fully entered the sleep mode.

In the sleep mode, the spindle motor is stopped and the ATA interface section is inactive. All I/O register outputs are in high-impedance state.

The only way to release the device from sleep mode is to execute a software or hardware reset.

At command issuance (I/O registers setting contents)					
1F7 _H (CM)	X'99' or X'E6'				
1F6 _H (DH)	x	x	x	DV	xx
1F5 _H (CH)	xx				
1F4 _H (CL)	xx				
1F3 _H (SN)	xx				
1F2 _H (SC)	xx				
1F1 _H (FR)	xx				

At command completion (I/O registers contents to be read)					
1F7 _H (ST)	Status information				
1F6 _H (DH)	x	x	x	DV	xx
1F5 _H (CH)	xx				
1F4 _H (CL)	xx				
1F3 _H (SN)	xx				
1F2 _H (SC)	xx				
1F1 _H (ER)	Error information				

(16) SMART (X'B0)

This command predicts the occurrence of device failures depending on the subcommand specified in the FR register. If the FR register contains values that are not supported with the command, the Aborted Command error is issued.

Before issuing the command, the host must set the key values in the CL and CH registers (4Fh in the CL register and C2h in the CH register). If the key values are incorrect, the Aborted Command error is issued.

If the failure prediction function is disabled, the device returns the Aborted Command error to subcommands other than those of the SMART Enable Operations (with the FR register set to D8h).

If the failure prediction function is enabled, the device collects and updates data on specific items. The values of items whose data is collected and updated by the device in order to predict device failures are hereinafter referred to as attribute values.

- The disk drive has a drive-specific function. When the temperature becomes about -20°C or lower, this function restricts the ENABLE/DISABLE ATTRIBUTE AUTOSAVE function of the SMART function. When it is restricted, the data is only updated in the memory of the disk drive and not written into the system area (temporarily suspended). (When the temperature is about -20°C or higher, the disk drive operates depending on whether the ENABLE/DISABLE ATTRIBUTE AUTOSAVE function is enabled or disabled, and the data in the memory and in the system area are updated simultaneously.)

Table 5.7 Features register values (subcommands) and functions (1 of 3)

Features Register	Function
X'D0'	<p>SMART READ DATE: A device that received this subcommand asserts the BSY bit and saves all the updated attribute values. The device then clears the BSY bit and transfers 512-byte attribute value information to the host.</p> <p>* For information about the format of the attribute value information, see Table 5.8.</p>
X'D1'	<p>SMART READ ATTRIBUTE THRESHOLDS: This subcommand is used to transfer 512-byte insurance failure threshold value data to the host.</p> <p>* For information about the format of the insurance failure threshold value data, see Table 5.9.</p>
X'D2'	<p>SMART ENABLE/DISABLE ATTRIBUTE AUTOSAVE: Enables (by setting the SC register to a value other than 00h) or disables (by setting the SC register to 00h) a function that automatically saves device attribute values ("automatic attribute save function"). This setting is held regardless of whether the device is turned on or off. If the automatic attribute save function is enabled and more than 15 minutes has elapsed since the last time that attributes were saved, then the attributes are saved. However, if the automatic attribute save function is disabled, the attributes are not saved. Upon receiving this subcommand, a device asserts BSY, enables or disables the automatic attribute save function, and clears BSY.</p>
X'D3'	<p>SMART SAVE ATTRIBUTE VALUES: When the device receives this subcommand, it asserts the BSY bit, saves device attribute value data, and then clears the BSY bit.</p>
X'D4'	<p>SMART EXECUTIVE OFF-LINE IMMEDIATE: A device which receives this command asserts the BSY bit, then starts collecting the off-line data specified in the SN register, or stops. In the off-line mode, after BSY is cleared, off-line data are collected. In the captive mode, it collects off-line data with the BSY assertion as is, then clears the BSY when collection of data is completed.</p> <p><u>SN Off-line data collection mode</u></p> <p>00h: Off-line diagnosis (off-line mode) 01h: Simple self-test (off-line mode) 02h: Comprehensive self-test (off-line mode) 03h: Conveyance self-test (off-line mode) 04h: Selective self-test (off-line mode) 7Fh: Self-test stop 81h: Simple self-test (captive mode) 82h: Comprehensive self-test (captive mode) 83h: Conveyance self-test (captive mode) 84h: Selective self-test (captive mode)</p>

Table 5.7 Features register values (subcommands) and functions (2 of 3)

Features Register	Function																					
X'D5'	<p>SMART READ LOG: A device which receives this sub-command asserts the BSY bit, then reads the log sector specified in the SN register. Next, it clears the BSY bit and transmits the log sector to the host computer.</p> <table border="1" data-bbox="553 436 1089 701"> <thead> <tr> <th>SN:</th> <th>SC:</th> <th>Log sector</th> </tr> </thead> <tbody> <tr> <td>00h:</td> <td>01h:</td> <td>SMART log directory</td> </tr> <tr> <td>01h:</td> <td>01h:</td> <td>SMART summary error log</td> </tr> <tr> <td>02h:</td> <td>33h:</td> <td>SMART comprehensive error log</td> </tr> <tr> <td>06h:</td> <td>01h:</td> <td>SMART self-test log</td> </tr> <tr> <td>09h:</td> <td>01h:</td> <td>SMART selective self-test log</td> </tr> <tr> <td>80h-9Fh:</td> <td>01h-10h:</td> <td>Host vendor log</td> </tr> </tbody> </table> <p>* See Table 5.16 concerning the SMART error log data format. See Table 5.18 concerning the SMART self-test log data format. See Table 5.19 concerning the SMART selective self-test log data format.</p>	SN:	SC:	Log sector	00h:	01h:	SMART log directory	01h:	01h:	SMART summary error log	02h:	33h:	SMART comprehensive error log	06h:	01h:	SMART self-test log	09h:	01h:	SMART selective self-test log	80h-9Fh:	01h-10h:	Host vendor log
SN:	SC:	Log sector																				
00h:	01h:	SMART log directory																				
01h:	01h:	SMART summary error log																				
02h:	33h:	SMART comprehensive error log																				
06h:	01h:	SMART self-test log																				
09h:	01h:	SMART selective self-test log																				
80h-9Fh:	01h-10h:	Host vendor log																				
X'D6'	<p>SMART WRITE LOG: A device which receives this sub-command asserts the BSY bit and when it has prepared to receive data from the host computer, it sets DRQ and clears the BSY bit. Next, it receives data from the host computer and writes the specified log sector in the SN register.</p> <table border="1" data-bbox="553 1108 1089 1220"> <thead> <tr> <th>SN:</th> <th>SC:</th> <th>Log sector</th> </tr> </thead> <tbody> <tr> <td>09h:</td> <td>01h:</td> <td>SMART selective self-test log</td> </tr> <tr> <td>80h-9Fh:</td> <td>01h-10h:</td> <td>Host vendor log</td> </tr> </tbody> </table> <p>* The host can write any desired data in the host vendor log.</p>	SN:	SC:	Log sector	09h:	01h:	SMART selective self-test log	80h-9Fh:	01h-10h:	Host vendor log												
SN:	SC:	Log sector																				
09h:	01h:	SMART selective self-test log																				
80h-9Fh:	01h-10h:	Host vendor log																				
X'D8'	<p>SMART ENABLE OPERATIONS: This subcommand enables the failure prediction feature. The setting is maintained even when the device is turned off and then on. When the device receives this subcommand, it asserts the BSY bit, enables the failure prediction feature, and then clears the BSY bit.</p>																					
X'D9'	<p>SMART DISABLE OPERATIONS: This subcommand disables the failure prediction feature. The setting is maintained even when the device is turned off and then on. When the device receives this subcommand, it asserts the BSY bit, disables the failure prediction feature, and then clears the BSY bit.</p>																					

Table 5.7 Features register values (subcommands) and functions (3 of 3)

Features Register	Function
X'DA'	<p>SMART RETURN STATUS:</p> <p>When the device receives this subcommand, it asserts the BSY bit and saves the current device attribute values. Then the device compares the device attribute values with insurance failure threshold values. If there is an attribute value exceeding the threshold, F4h and 2Ch are loaded into the CL and CH registers. If there are no attribute values exceeding the thresholds, 4Fh and C2h are loaded into the CL and CH registers. After the settings for the CL and CH registers have been determined, the device clears the BSY bit</p>
X'DB'	<p>SMART ENABLE/DISABLE AUTO OFF-LINE:</p> <p>This sets automatic off-line data collection in the enabled (when the SC register specification \neq 00h) or disabled (when the SC register specification = 00) state. This setting is preserved whether the drive's power is switched on or off.</p> <p>If 24 hours have passed since the power was switched on, or since the last time that off-line data were collected, off-line data collection is performed without relation to any command from the host computer.</p>

The host must regularly issue the SMART READ DATA subcommand (FR register = D0h), SMART SAVE ATTRIBUTE VALUES subcommand (FR register = D3h), or SMART RETURN STATUS subcommand (FR register = DAh) to save the device attribute value data on a medium.

Alternatively, the device must issue the SMART ENABLE-DISABLE ATTRIBUTE AUTOSAVE subcommand (FR register = D2h) to use a feature which regularly saves the device attribute value data to a medium.

The host can predict failures in the device by periodically issuing the SMART RETURN STATUS subcommand (FR register = DAh) to reference the CL and CH registers.

If an attribute value is below the insurance failure threshold value, the device is about to fail or the device is nearing the end of its life. In this case, the host recommends that the user quickly back up the data.

At command issuance (I-O registers setting contents)								
1F7 _H (CM)	1	0	1	1	0	0	0	0
1F6 _H (DH)	x	x	x	DV	xx			
1F5 _H (CH)	Key (C2h)							
1F4 _H (CL)	Key (4Fh)							
1F3 _H (SN)	xx							
1F2 _H (SC)	xx							
1F1 _H (FR)	Subcommand							

At command completion (I-O registers setting contents)								
1F7 _H (ST)	Status information							
1F6 _H (DH)	x	x	x	DV	xx			
1F5 _H (CH)	Key-failure prediction status (C2h/2Ch)							
1F4 _H (CL)	Key-failure prediction status (4Fh/F4h)							
1F3 _H (SN)	xx							
1F2 _H (SC)	xx							
1F1 _H (ER)	Error information							

The attribute value information is 512-byte data; the format of this data is shown the following Table 5.8. The host can access this data using the SMART READ DATE subcommand (FR register = D0h). The insurance failure threshold value data is 512-byte data; the format of this data is shown the following Table 5.9. The host can access this data using the SMART READ ATTRIBUTE THRESHOLDS subcommand (FR register = D1h).

Table 5.8 Format of device attribute value data

Byte	Item	
00 01	Data format version number	
02	Attribute 1	Attribute ID
03 04		Status flag
05		Current attribute value
06		Attribute value for worst case so far
07 to 0C		Raw attribute value
0D		Reserved
0E to 169		Attribute 2 to attribute 30
16A	Off-line data collection status	
16B	Self-test execution status	
16C, 16D	Off-line data collection execution time [sec.]	
16E	Reserved	
16F	Off-line data collection capability	
170, 171	Trouble prediction capability flag	
172	Error logging capability	
173	(Self-test error detection point)	
174	Simple self-test (Quick Test) execution time [min.]	
175	Comprehensive self-test (Comprehensive Test) execution time [min.]	
176	Conveyance self-test execution time [min.]	
177 to 181	Reserved	
182 to 1FE	Vendor unique	
1FF	Check sum	

Table 5.9 Format of insurance failure threshold value data

Byte	Item	
00 01	Data format version number	
02	Threshold 1	Attribute ID
03		Insurance failure threshold
04 to 0D		Reserved
0E to 169	Threshold 2 to Threshold 30	(The format of each threshold value is the same as that of bytes 02 to 0D.)
16A to 17B	Reserved	
17C to 1FE	Vendor unique	
1FF	Check sum	

- Data format version number

The data format version number indicates the version number of the data format of the device attribute values or insurance failure thresholds. The data format version numbers of the device attribute values and insurance failure thresholds are the same. When a data format is changed, the data format version numbers are updated.

- Attribute ID

The attribute ID is defined as follows:

Attribute ID	Attribute name
0	(Indicates unused attribute data.)
1	Read Error Rate
2	Throughput Performance
3	Spin Up Time
4	Start/Stop Count
5	Reallocated Sector Count
7	Seek Error Rate
8	Seek Time Performance
9	Power-On Hours Count
10	Spin Retry Count
12	Drive Power Cycle Count
192	Emergency Retract Cycle Count
193	Load/Unload Cycle Count
194	HDA Temperature
195	ECC On the Flag Count
196	Reallocated Event Count
197	Current Pending Sector Count
198	Off-Line Scan Uncorrectable Sector Count
199	Ultra ATA CRC Error Count
200	Write Error Rate
203	Run Out

- **Status Flag**

Bit	Meaning
0	If this bit is 1, it indicates normal operations are assured with the attribute when the attribute value exceeds the threshold value.
1	If this bit is 1 (0), it indicates the attribute only updated by an on-line test (off-line test).
2	If this bit 1, it indicates the attribute that represents performance.
3	If this bit 1, it indicates the attribute that represents an error rate.
4	If this bit 1, it indicates the attribute that represents the number of occurrences.
5	If this bit 1, it indicates the attribute that can be collected/saved even if the drive fault prediction function is disabled.
6 to 15	Reserve bit

- **Current attribute value**

It indicates the normalized value of the original attribute value. The value deviates in a range of 01h to 64h (range of 01h to C8h for the ultra ATA CRC error rate). It indicates that the closer the value is to 01h, the higher the possibility of a failure. The host compares the attribute value with the threshold value. If the attribute value is larger than the threshold value, the drive is determined to be normal.

- **Attribute value for the worst case so far**

This is the worst attribute value among the attribute values collected to date. This value indicates the state nearest to a failure so far.

- **Raw attribute value**

Raw attributes data is retained.

- **Off-line data collection status**

Table 5.10 Off-line data collection status

Status Byte	Meaning
00h or 80h	Off-line data acquisition is not executed.
02h or 82h	Off-line data acquisition has ended without an error.
04h or 84h	Off-line data acquisition is interrupted by a command from the host.
05h or 85h	Off-line data acquisition has ended before completion because of a command from the host.
06h or 86h	Off-line data acquisition has ended before completion because of an error that makes acquisition impossible. (Not used)
40 to 7Fh C0h to FFh	Vendor unique (Not used)
01h or 81h 03h or 83h 07h or 3Fh 87h to BFh	Reserved

- Self-test execution status

Table 5.11 Self-test execution status

Bit	Meaning
0 to 3:	Remainder of the self-test is indicated as a percentage in a range of "0h to 9h" (corresponding to 0 to 90 %).
4 to 7:	Self-test execution status
= 0h:	Self-test has ended successfully, or self-test has not been executed.
= 1h:	Self-test is suspended by the host.
= 2h:	Self-test is interrupted by a soft/hard reset from the host.
= 3h:	Self-test cannot be executed.
= 4h:	Self-test has ended with an abnormality because of unknown contents.
= 5h:	Self-test has ended with "Write/Read Test" error.
= 6h:	Self-test has ended with "Servo Check," error.
= 7h:	Self-test has ended with "SMART Drive Error Log Check," "Random Read Test," "Adjacent G-List Test," or "Read Scan Test" error.
= 8h:	Self-test has ended with "Pre-SMART Check," or "Post-SMART Check" error.
= 9h:	Reserved
= Ah:	Reserved
= Bh:	Reserved
= Ch to Eh:	Reserved
= Fh:	Self-test is in progress.

- Off-line data collection capability

Indicates the method of off-line data collection carried out by the drive. If the off-line data collection capability is 0, it indicates that off-line data collection is not supported.

Table 5.12 Off-line data collection capability

Bit	Meaning
0	If this bit is 1, it indicates that the SMART EXECUTE OFF-LINE IMMEDIATE sub-command (FR register = D4h) is supported.
1	Vendor unique
2	If this bit is 1, it indicates that acquisition of off-line data under execution is aborted when a new command is received.
3	If this bit is 1, it indicates that the SMART Off-line Read Scanning Technology is supported.
4	If this bit is 1, it indicates that the SMART Self-test function is supported.
5	If this bit is 1, it indicates that the SMART Conveyance Self-test is supported.
6	If this bit is 1, it indicates that the SMART Selective Self-test is supported.
7	Reserved bits

- Failure prediction capability flag

Table 5.13 Failure prediction capability flag

Bit	Meaning
0	If this bit is 1, it indicates that the attribute value is saved on media before the drive enters the power save mode.
1	If this bit is 1, it indicates that the attribute value is saved automatically after the pre-set operation of the drive.
2 to 15	Reserved bits

- Error logging capability

Table 5.14 Error logging capability

Bit	Meaning
0	If this bit is 1, it indicates that the drive error logging function is supported.
1 to 7	Reserved bits

- Check sum

Two's complement of the lower byte, obtained by adding 511-byte data one byte at a time from the beginning.

- Insurance failure threshold

The limit of a varying attribute value. The host compares the attribute values with the thresholds to identify a failure.

Table 5.15 Log directory data format

Byte	Item	
00 01	SMART Logging Version	
02	Number of sectors of Address "01h"	
03	Reserved	
04	Number of sectors of Address "02h"	
05-0B	Reserved	
0C	Number of sectors of Address "06h"	
0D-11	Reserved	
12	Number of sectors of Address "09h"	
13-FF	Reserved	
100	Address 80h	Number of sector
101		Reserved
102	Address 81h	"102" and "13F" are both the same format as "100-101"
13F	Address 9Fh	
140	Reserved	
1FF		

- SMART error logging

If the device detects an unrecoverable error during execution of a command received from the host, the device registers the error information in the SMART Summary Error Log (see Table 5.16) and the SMART Comprehensive Error Log (see Table 5.17), and saves the information on media.

The host issues the SMART Read Log Sector sub-command (FR register = D5h, SN register = 01h, SC register = 01h) and can read the SMART Summary Error Log.

The host issues the SMART Read Log Sector sub-command (FR register = D5h, SN register = 02h, SC register = 33h) and can read the SMART Comprehensive Error Log.

Table 5.16 Data format of SMART Summary Error Log

Byte	Item		
00	Version of this function		
01	Pointer for the latest "Error Log Data Structure"		
02 to 0D	First command data structure		
0E to 19	Second command data structure		
1A to 25	Third command data structure		
26 to 31	Fourth command data structure		
32	Error log data structure	Fifth Command data structure	Device Control register value
33			Features register value
34			Sector Count register value
35			Sector Number register value
36			Cylinder Low register value
37			Cylinder High register value
38			Drive/Head register value
39			Command register value
3A to 3D			Elapsed time after the power-on sequence (unit: ms)
3E			Error data structure
3F	Error register value		
40	Sector Count register value		
41	Sector Number register value		
42	Cylinder Low register value		
43	Cylinder High register value		
44	Drive/Head register value		
45	Status register value		
46 to 58	Vendor unique		
59	State		
5A, 5B	Power-on time (unit: h)		
5C to 1C3	Error log data structure 2 to Error log data structure 5	Format of each error log data structure is same as those of bytes 02 to 5B.	
1C4, 1C5	Number of unrecoverable errors that have occurred.		
1C6 to 1FE	Reserved		
1FF	Check sum		

- **Command data structure**
Indicates the command received when an error occurs.
- **Error data structure**
Indicates the status register when an error occurs.
- **Total number of drive errors**
Indicates total number of errors registered in the error log.
- **Check sum**
Two's complementary for the lowest-order 1 byte that is obtained by adding 1 byte after another for as many as 511 bytes beginning from the top of the structure.
- **Status**
Bits 0 to 3: Indicates the drive status when received error commands according to the following table.

Bits 4 to 7: Vendor unique

Status	Meaning
0	Unclear status
1	Sleep status
2	Standby status
3	Active status (BSY bit = 0)
4	Off-line data collection being executed
5 to F	Reserved

Table 5.17 Data format of SMART Comprehensive Error Log

Byte	First sector	Next sector
00h	SMART Error Logging 01h	Reserved
01h	Index Pointer Latest Error Data Structure.	Reserved
02h...5Bh	1 st Error Log Data Structure	Data Structure 5n + 1
5Ch...B5h	2 nd Error Log Data Structure	Data Structure 5n + 2
B6h...10Fh	3 rd Error Log Data Structure	Data Structure 5n + 3
110h...169h	4 th Error Log Data Structure	Data Structure 5n + 4
16Ah...1C3h	5 th Error Log Data Structure	Data Structure 5n + 5
1C4h...1C5h	Total Error Count	Reserved
1C6h...1FEh	Reserved	Reserved
1FFh	Checksum	Checksum

- **SMART self-test**

The host computer can issue the SMART Execute Off-line Immediate sub-command (FR Register = D4h) and cause the device to execute a self-test. When the self-test is completed, the device saves the SMART self-test log to the disk medium.

The host computer can issue the SMART Read Log Sector sub-command (FR Register = D5h, SN Register = 06h, SC register = 01h) and can read the SMART self-test log.

Table 5.18 SMART self-test log data format

Byte	Item	
00, 01	Self-test log data structure	
02	Self-test log 1	Self-test number (SN Register Value)
03		Self-test execution status
04, 05		Life time. Total power-on time [hours]
06		Self-test error No.
07 to 0A		Error LBA
0B to 19		Vendor unique
1A to 1F9		Self-test log 2 to 21
1FA, 1FB	Vendor unique	
1FC	Self-test index	
1FD, 1FE	Reserved	
1FF	Check sum	

- **Self-test number**

Indicates the type of self-test executed.

- **Self-test execution status**

Same as byte 16Bh of the attribute value.

- **Self-test index**

If this is "00h", it indicates the status where the self-test has never been executed.

- **Check sum**

Two's complementary for the lowest-order 1 byte that is obtained by adding 1 byte after another for as many as 511 bytes from the top.

Table 5.19 Selective self-test log data structure

Offset	Description		Initial
00h, 01h	Data Structure Revision Number		01h, 00h
02h...09h	Test Span 1	Starting LBA	00h...00h
0Ah...11h		Ending LBA	00h...00h
12h...19h	Test Span 2	Starting LBA	00h...00h
1Ah...21h		Ending LBA	00h...00h
22h...29h	Test Span 3	Starting LBA	00h...00h
2Ah...31h		Ending LBA	00h...00h
32h...39h	Test Span 4	Starting LBA	00h...00h
3Ah...41h		Ending LBA	00h...00h
42h...49h	Test Span 5	Starting LBA	00h...00h
4Ah...51h		Ending LBA	00h...00h
52h...151h	Reserved		00h...00h
152h...1EBh	Vender Unique		00h...00h
1Ech...1F3h	Current LBA under test		00h...00h
1F4h...1F5h	Current Span under test		00h...00h
1F6h...1F7h	Feature Flags		00h...00h
1F8h	Vender Unique	Offline Execution Flag	00h
1F9h		Selective Offline Scan Number	00h
1FAh, 1FBh		Reserved	00h, 00h
1FCh, 1FDh	Selective Self-test pending time [min]		00h, 00h
1FEh, 1FFh	Check sum		00h, FFh

- **Test span**

Selective self-test log provides for the definition of up to five test spans. If the starting and ending LBA values for a test span are both zero, a test span is not defined and not tested.

- **Current LBA under test**

As the self-test progress, the device shall modify this value to contain the LBA currently being tested.

- **Current span under test**

As the self-test progress, the device shall modify this value to contain the test span number currently being tested.

- Feature Flags

Table 5.20 Selective self-test feature flags

Bit	Description
0	Vendor specific (unused)
1	When set to one, perform off-line scan after selective test
2	Vendor specific (unused)
3	When set to one, off-line scan after selective test is pending.
4	When set to one, off-line scan after selective test is active.
5...15	Reserved

Bit [1] shall be written by the host and returned unmodified by the device. Bit [3:4] shall be written as zeros by the host and the device shall modify them as the test progress.

- Selective Self-test pending time [min]

The selective self-test pending time is the time in minutes from power-on to the resumption of the off-line testing if the pending bit is set.

(17) DEVICE CONFIGURATION (X'B1')

Individual Device Configuration Overlay feature set commands are identified by the value placed in the Features register. The following table shows these Features register values. If this command sets with the reserved value of Features register, an aborted error is posted.

FR values	Command
C0h	DEVICE CONFIGURATION RESTORE
C1h	DEVICE CONFIGURATION FREEZE
C2h	DEVICE CONFIGURATION IDENTIFY
C3h	DEVICE CONFIGURATION SET
00h-BFh, C4h-FFh	Reserved

At command issuance (I-O register contents)								
1F7 _h (CM)	1	0	1	1	0	0	0	1
1F6 _h (DH)	x	x	x	DV	xx			
1F5 _h (CH)	xx							
1F4 _h (CL)	xx							
1F3 _h (SN)	xx							
1F2 _h (SC)	xx							
1F1 _h (FR)	C0h/C1h/C2h/C3h							

At command completion (I-O register contents)								
1F7 _h (ST)	Status information							
1F6 _h (DH)	x	x	x	DV	xx			
1F5 _h (CH)	xx							
1F4 _h (CL)	xx							
1F3 _h (SN)	xx							
1F2 _h (SC)	xx							
1F1 _h (ER)	Error information							

- **DEVICE CONFIGURATION RESTORE (FR = C0h)**

The DEVICE CONFIGURATION RESTORE command disables any setting previously made by a DEVICE CONFIGURATION SET command and returns the content of the IDENTIFY DEVICE command response to the original settings as indicated by the data returned from the execution of a DEVICE CONFIGURATION IDENTIFY command. After execution of this command, the settings are kept for the device power down or reset.

If a Host Protected Area has been set by a SET MAX ADDRESS (EXT) command, or if DEVICE CONFIGURATION FREEZE LOCK is set, an aborted error is posted.

- **DEVICE CONFIGURATION FREEZE LOCK (FR = C1h)**

The DEVICE CONFIGURATION FREEZE LOCK command prevents accidental modification of the Device Configuration Overlay settings. After successful execution of a DEVICE CONFIGURATION FREEZE LOCK command, all DEVICE CONFIGURATION SET, DEVICE CONFIGURATION FREEZE LOCK, DEVICE CONFIGURATION IDENTIFY, and DEVICE CONFIGURATION RESTORE commands are aborted by the device. The DEVICE CONFIGURATION FREEZE LOCK condition is cleared by a power-down, not cleared by a hardware or software reset.

If the device has executed a previous DEVICE CONFIGURATION FREEZE LOCK command since power-up, an aborted error is posted.

- **DEVICE CONFIGURATION: IDENTIFY (FR = C2h)**

The DEVICE CONFIGURATION IDENTIFY command returns a 512-byte data structure is shown in Table 5.21. The content of this data structure indicates the selectable commands, modes, and feature sets that the device is capable of supporting. If a DEVICE CONFIGURATION SET command has been issued reducing the capabilities, the response to an IDENTIFY DEVICE command will reflect the reduced set of capabilities, while the DEVICE CONFIGURATION IDENTIFY command will reflect the entire set of selectable capabilities.

If the device has executed a previous DEVICE CONFIGURATION FREEZE LOCK command since power-up, an aborted error is posted.

- **DEVICE CONFIGURATION SET (FR = C3h)**

The DEVICE CONFIGURATION SET command allows reducing the set of optional commands, modes, or feature sets supported by a device as indicated by a DEVICE CONFIGURATION IDENTIFY command. The format of the overlay transmitted by the device is described in Table 5.21. As a result to the limitation of the function by the DEVICE CONFIGURATION SET command, is reflected in IDENTIFY information. When the bits in these words are cleared, the device no longer supports the indicated command, mode, or feature set. If a bit is set in the overlay transmitted by the device that is not set in the overlay received from a DEVICE CONFIGURATION IDENTIFY command, no action is taken for that bit. After execution of this command, the settings are kept for the device power down or reset.

If the restriction of Multiword DMA modes or Ultra DMA modes is executed, a SET FEATURES command should be issued for the modes restriction prior the DEVICE CONFIGURATION SET command is issued.

When the Automatic Acoustic Management function is assumed to be unsupported, Automatic Acoustic Management is prohibited beforehand by SET FEATURES command (FR=C2h).

If a DEVICE CONFIGURATION SET command has already modified the original settings as reported by a DEVICE CONFIGURATION IDENTIFY command, if DEVICE CONFIGURATION FREEZE LOCK is set, if any of the bit modification restrictions described are violated, or if a Host Protected Area has been established by the execution of a SET MAX ADDRESS (EXT) command, an aborted error is posted.

Table 5.21 DEVICE CONFIGURATION IDENTIFY data structure (1 of 2)

Word	Value	Content
0	X'0002'	Data structure revision
1	X'0007'	Multiword DMA modes supported Reflected in IDENTIFY information "WORD63". Bit 15-3: Reserved Bit 2: 1 = Multiword DMA mode 2 and below are supported Bit 1: 1 = Multiword DMA mode 1 and below are supported Bit 0: 1 = Multiword DMA mode 0 is supported
2	X'003F'	Ultra DMA modes supported Reflected in IDENTIFY information "WORD88". Bit 15-6: Reserved Bit 5: 1 = Ultra DMA mode 5 and below are supported Bit 4: 1 = Ultra DMA mode 4 and below are supported Bit 3: 1 = Ultra DMA mode 3 and below are supported Bit 2: 1 = Ultra DMA mode 2 and below are supported Bit 1: 1 = Ultra DMA mode 1 and below are supported Bit 0: 1 = Ultra DMA mode 0 is supported
3-6	-	Maximum LBA address Reflected in IDENTIFY information "WORD60-61". (WORD100-103) *
7	X'30CF' (X'39CF') *	Command set/feature set supported Reflected in IDENTIFY information "WORD82-87". Bit 15-14: Reserved Bit 13: 1 = SMART Conveyance self-test supported Bit 12: 1 = SMART Selective self-test supported Bit 11: * 1 = FUA (Forced Unit Access) supported Bit 10: Reserved Bit 9: 1 = Streaming feature set supported Bit 8: * 1 = 48-bit Addressing feature set supported Bit 7: 1 = Host Protected Area feature set supported Bit 6: 1 = Automatic acoustic management supported Bit 5: 1 = READ/WRITE DMA QUEUED commands supported Bit 4: 1 = Power-up in Standby feature set supported Bit 3: 1 = Security feature set supported Bit 2: 1 = SMART error log supported Bit 1: 1 = SMART self-test supported Bit 0: 1 = SMART feature set supported

Table 5.21 DEVICE CONFIGURATION IDENTIFY data structure (2 of 2)

Word	Value	Content
8-254	X'0000'	Reserved
255	X'xxA5'	Integrity word. Bits 15:8 contains the data structure checksum that is the two's complement of the sum of all byte in words 0 through 254 and the byte consisting of bits 7:0 of word 255.

*: When "48 bit LBA" of the option (customize) is supported, same number of LBA as WORD60-61 is displayed.

(18) READ MULTIPLE (X'C4')

The READ MULTIPLE Command performs the same as the READ SECTOR(S) Command except that when the device is ready to transfer data for a block of sectors, and enters the interrupt pending state only before the data transfer for the first sector of the block sectors. In the READ MULTIPLE command operation, the DRQ bit of the Status register is set only at the start of the data block, and is not set on each sector.

The number of sectors per block is defined by a successful SET MULTIPLE MODE Command. The SET MULTIPLE MODE command should be executed prior to the READ MULTIPLE command.

If the number of requested sectors is not divided evenly (having the same number of sectors [block count]), as many full blocks as possible are transferred, then a final partial block is transferred. The number of sectors in the partial block to be transferred is n where $n = \text{remainder of ("number of sectors" / "block count")}$.

If the READ MULTIPLE command is issued before the SET MULTIPLE MODE command is executed or when the READ MULTIPLE command is disabled, the device rejects the READ MULTIPLE command with an ABORTED COMMAND error.

Figure 5.2 shows an example of the execution of the READ MULTIPLE command.

- Block count specified by SET MULTIPLE MODE command = 4 (number of sectors in a block)
- READ MULTIPLE command specifies;

Number of requested sectors = 9 (Sector Count register = 9)

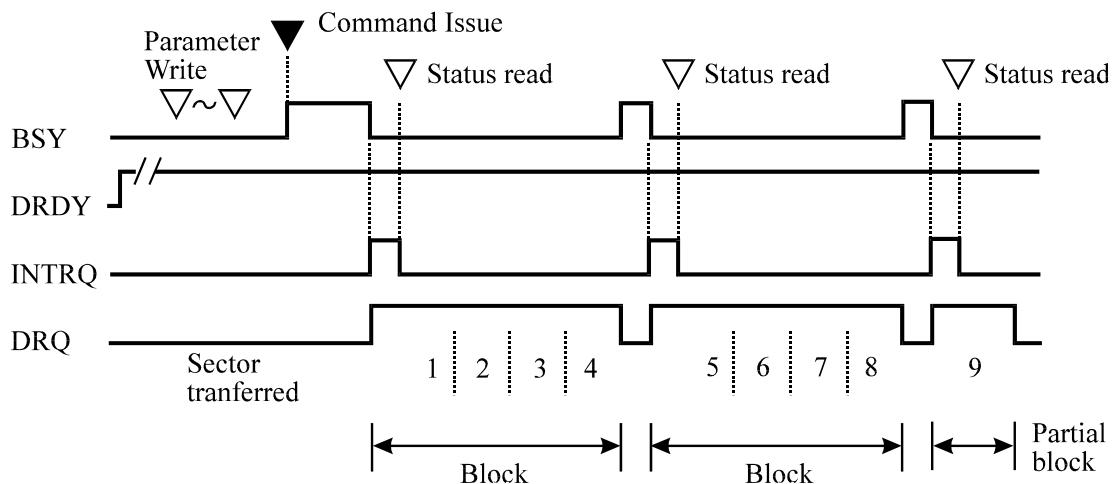

Figure 5.2 Execution example of READ MULTIPLE command

At command issuance (I/O registers setting contents)					
1F7 _H (CM)	1	1	0	0	0 1 0 0
1F6 _H (DH)	x	L	x	DV	Start head No. / LBA [MSB]
1F5 _H (CH)	Start cylinder No. [MSB] / LBA				
1F4 _H (CL)	Start cylinder No. [LSB] / LBA				
1F3 _H (SN)	Start sector No. / LBA [LSB]				
1F2 _H (SC)	Transfer sector count				
1F1 _H (FR)	xx				

At command completion (I/O registers contents to be read)					
1F7 _H (ST)	Status information				
1F6 _H (DH)	x	L	x	DV	End head No. / LBA [MSB]
1F5 _H (CH)	End cylinder No. [MSB] / LBA				
1F4 _H (CL)	End cylinder No. [LSB] / LBA				
1F3 _H (SN)	End sector No. / LBA [LSB]				
1F2 _H (SC)	00(*1)				
1F1 _H (ER)	Error information				

- *1 If the command is terminated due to an error, the remaining number of sectors for which data was not transferred is set in this register.

(19) WRITE MULTIPLE (X'C5')

This command is similar to the WRITE SECTOR(S) command. The device does not generate interrupts (assertion of the INTRQ) signal) on each sector but on the transfer of a block which contains the number of sectors for which the number is defined by the SET MULTIPLE MODE command. The DRQ bit of the Status register is required to set only at the start of the data block, not on each sector.

The number of sectors per block is defined by a successful SET MULTIPLE MODE command. The SET MULTIPLE MODE command should be executed prior to the WRITE MULTIPLE command.

If the number of requested sectors is not divided evenly (having the same number of sectors [block count]), as many full blocks as possible are transferred, then a final partial block is transferred. The number of sectors in the partial block to be transferred is n where $n = \text{remainder of ("number of sectors" / "block count")}$.

If the WRITE MULTIPLE command is issued before the SET MULTIPLE MODE command is executed or when WRITE MULTIPLE command is disabled, the device rejects the WRITE MULTIPLE command with an ABORTED COMMAND error.

Disk errors encountered during execution of the WRITE MULTIPLE command are posted after attempting to write the block or the partial block that was transferred. Write operation ends at the sector where the error was encountered even if the sector is in the middle of a block. If an error occurs, the subsequent block shall not be transferred. Interrupts are generated when the DRQ bit of the Status register is set at the beginning of each block or partial block.

The contents of the command block registers related to addresses after the transfer of a data block containing an erred sector are undefined. To obtain a valid error information, the host should retry data transfer as an individual request.

At command issuance (I/O registers setting contents)						
1F7 _H (CM)	1	1	0	0	0	1 0 1
1F6 _H (DH)	x	L	x	DV	Start head No. / LBA [MSB]	
1F5 _H (CH)	Start cylinder No. [MSB] / LBA					
1F4 _H (CL)	Start cylinder No. [LSB] / LBA					
1F3 _H (SN)	Start sector No. / LBA [LSB]					
1F2 _H (SC)	Transfer sector count					
1F1 _H (FR)	xx					

At command completion (I/O registers contents to be read)					
1F7 _H (ST)	Status information				
1F6 _H (DH)	x	L	x	DV	End head No. / LBA [MSB]
1F5 _H (CH)	End cylinder No. [MSB] / LBA				
1F4 _H (CL)	End cylinder No. [LSB] / LBA				
1F3 _H (SN)	End sector No. / LBA [LSB]				
1F2 _H (SC)	00				
1F1 _H (ER)	Error information				

(20) SET MULTIPLE MODE (X'C6')

This command enables the device to perform the READ MULTIPLE and WRITE MULTIPLE commands. The block count (number of sectors in a block) for these commands is also specified by the SET MULTIPLE MODE command.

The number of sectors per block is written into the Sector Count register. The IDD supports 2, 4, 8, 16 and 32 (sectors) as the block counts.

Upon receipt of this command, the device sets the BSY bit of the Status register and checks the contents of the Sector Count register. If the contents of the Sector Count register are valid and are supported block count, the value is stored for all subsequent READ MULTIPLE and WRITE MULTIPLE commands. Execution of these commands is then enabled. If the value of the Sector Count register is not a supported block count, an ABORTED COMMAND error is posted and the READ MULTIPLE and WRITE MULTIPLE commands are disabled.

If the contents of the Sector Count register is 0, when the SET MULTIPLE MODE command is issued, the READ MULTIPLE and WRITE MULTIPLE commands are disabled.

When the SET MULTIPLE MODE command operation is completed, the device clears the BSY bit and generates an interrupt.

At command issuance (I/O registers setting contents)								
1F7 _H (CM)	1	1	0	0	0	1	1	0
1F6 _H (DH)	x	x	x	DV	xx			
1F5 _H (CH)	xx							
1F4 _H (CL)	xx							
1F3 _H (SN)	xx							
1F2 _H (SC)	Sector count/block							
1F1 _H (FR)	xx							

After power-on the READ MULTIPLE and WRITE MULTIPLE command operation are disabled as the default mode.

At command completion (I/O registers contents to be read)					
1F7 _H (ST)	Status information				
1F6 _H (DH)	x	x	x	DV	xx
1F5 _H (CH)	xx				
1F4 _H (CL)	xx				
1F3 _H (SN)	xx				
1F2 _H (SC)	Sector count/block				
1F1 _H (ER)	Error information				

(21) READ DMA (X'C8' or X'C9')

This command operates similarly to the READ SECTOR(S) command except for following events.

- The data transfer starts at the timing of DMARQ signal assertion.
- The device controls the assertion or negation timing of the DMARQ signal.
- The device posts a status as the result of command execution only once at completion of the data transfer.

When an error, such as an unrecoverable medium error, that the command execution cannot be continued is detected, the data transfer is stopped without transferring data of sectors after the erred sector. The device generates an interrupt using the INTRQ signal and posts a status to the host system. The format of the error information is the same as the READ SECTOR(S) command.

In LBA mode

The logical block address is specified using the start head No., start cylinder No., and first sector No. fields. At command completion, the logical block address of the last sector and remaining number of sectors of which data was not transferred, like in the CHS mode, are set.

The host system can select the DMA transfer mode by using the SET FEATURES command.

- Multiword DMA transfer mode 0 to 2
- Ultra DMA transfer mode 0 to 5

At command issuance (I/O registers setting contents)							
1F7 _H (CM)	1	1	0	0	1	0	0 R
1F6 _H (DH)	x	L	x	DV	Start head No. / LBA [MSB]		
1F5 _H (CH)	Start cylinder No. [MSB] / LBA						
1F4 _H (CL)	Start cylinder No. [LSB] / LBA						
1F3 _H (SN)	Start sector No. / LBA [LSB]						
1F2 _H (SC)	Transfer sector count						
1F1 _H (FR)	xx						

At command completion (I/O registers contents to be read)					
1F7 _H (ST)	Status information				
1F6 _H (DH)	x	L	x	DV	End head No. / LBA [MSB]
1F5 _H (CH)	End cylinder No. [MSB] / LBA				
1F4 _H (CL)	End cylinder No. [LSB] / LBA				
1F3 _H (SN)	End sector No. / LBA [LSB]				
1F2 _H (SC)	00 (*1)				
1F1 _H (ER)	Error information				

- *1 If the command is terminated due to an error, the remaining number of sectors of which data was not transferred is set in this register.

(22) WRITE DMA (X'CA' or X'CB')

This command operates similarly to the WRITE SECTOR(S) command except for following events.

- The data transfer starts at the timing of DMARQ signal assertion.
- The device controls the assertion or negation timing of the DMARQ signal.
- The device posts a status as the result of command execution only once at completion of the data transfer or completion of processing in the device.
- The device posts a status as the result of command execution only once at completion of the data transfer.

When an error, such as an unrecoverable medium error, that the command execution cannot be continued is detected, the data transfer is stopped without transferring data of sectors after the erred sector. The device generates an interrupt using the INTRQ signal and posts a status to the host system. The format of the error information is the same as the WRITE SECTOR(S) command.

A host system can select the following transfer mode using the SET FEATURES command.

- Multiword DMA transfer mode 0 to 2
- Ultra DMA transfer mode 0 to 5

At command issuance (I/O registers setting contents)							
1F7 _H (CM)	1	1	0	0	1	0	1 R
1F6 _H (DH)	x	L	x	DV	Start head No. / LBA [MSB]		
1F5 _H (CH)	Start cylinder No. [MSB] / LBA						
1F4 _H (CL)	Start cylinder No. [LSB] / LBA						
1F3 _H (SN)	Start sector No. / LBA [LSB]						
1F2 _H (SC)	Transfer sector count						
1F1 _H (FR)	xx						

At command completion (I/O registers contents to be read)					
1F7 _H (ST)	Status information				
1F6 _H (DH)	x	L	x	DV	End head No. / LBA [MSB]
1F5 _H (CH)	End cylinder No. [MSB] / LBA				
1F4 _H (CL)	End cylinder No. [LSB] / LBA				
1F3 _H (SN)	End sector No. / LBA [LSB]				
1F2 _H (SC)	00 (*1)				
1F1 _H (ER)	Error information				

- *1 If the command is terminated due to an error, the remaining number of sectors of which data was not transferred is set in this register.

(23) READ BUFFER (X'E4')

The host system can read the current contents of the data buffer of the device by issuing this command. Upon receipt of this command, the device sets the BSY bit of Status register and sets up for a read operation. Then the device sets the DRQ bit of Status register, clears the BSY bit, and generates an interrupt. After that, the host system can read up to 512 bytes of data from the buffer.

At command issuance (I/O registers setting contents)						
1F7 _H (CM)	1	1	1	0	0	0
1F6 _H (DH)	x	x	x	DV	xx	
1F5 _H (CH)	xx					
1F4 _H (CL)	xx					
1F3 _H (SN)	xx					
1F2 _H (SC)	xx					
1F1 _H (FR)	xx					

At command completion (I/O registers contents to be read)						
1F7 _H (ST)	Status information					
1F6 _H (DH)	x	x	x	DV	xx	
1F5 _H (CH)	xx					
1F4 _H (CL)	xx					
1F3 _H (SN)	xx					
1F2 _H (SC)	xx					
1F1 _H (ER)	Error information					

(24) FLUSH CACHE (X'E7')

This command is used to order to write every write cache data stored by the device into the medium. BSY bit is held at "1" until every data has been written normally or an error has occurred. The device performs every error recovery so that the data are read correctly.

When executing this command, the reading of the data may take several seconds if much data are to be read.

In case a non-recoverable error has occurred while the data is being read, the error generation address is put into the command block register before ending the command. This error sector is deleted from the write cache data, and the remaining cache data is written into the medium by the execution of the next Flush Cache command.

At command issuance (I-O register contents)					
1F7 _h (CM)	1	1	1	0	0 1 1 1
1F6 _h (DH)	x	x	x	DV	xx
1F5 _h (CH)	xx				
1F4 _h (CL)	xx				
1F3 _h (SN)	xx				
1F2 _h (SC)	xx				
1F1 _h (FR)	xx				

At command completion (I-O register contents to be read)					
1F7 _h (ST)	Status information				
1F6 _h (DH)	x	x	x	DV	xx
1F5 _h (CH)	xx				
1F4 _h (CL)	xx				
1F3 _h (SN)	xx				
1F2 _h (SC)	xx				
1F1 _h (ER)	Error information				

(25) WRITE BUFFER (X'E8')

The host system can overwrite the contents of the data buffer of the device with a desired data pattern by issuing this command. Upon receipt of this command, the device sets the BSY bit of the Status register. Then the device sets the DRQ bit of Status register and clears the BSY bit when the device is ready to receive the data. After that, 512 bytes of data is transferred from the host and the device writes the data to the buffer, then generates an interrupt.

At command issuance (I/O registers setting contents)							
1F7 _H (CM)	1	1	1	0	1	0	0
1F6 _H (DH)	x	x	x	DV	xx		
1F5 _H (CH)	xx						
1F4 _H (CL)	xx						
1F3 _H (SN)	xx						
1F2 _H (SC)	xx						
1F1 _H (FR)	xx						

At command completion (I/O registers contents to be read)							
1F7 _H (ST)	Status information						
1F6 _H (DH)	x	x	x	DV	xx		
1F5 _H (CH)	xx						
1F4 _H (CL)	xx						
1F3 _H (SN)	xx						
1F2 _H (SC)	xx						
1F1 _H (ER)	Error information						

(26) IDENTIFY DEVICE (X'EC')

The host system issues the IDENTIFY DEVICE command to read parameter information from the device. Upon receipt of this command, the drive sets the BSY bit to one, prepares to transfer the 256 words of device identification data to the host, sets the DRQ bit to one, clears the BSY bit to zero, and generates an interrupt. After that, the host system reads the information out of the sector buffer. Table 5.22 shows the values of the parameter words and the meaning in the buffer.

At command issuance (I/O registers setting contents)							
1F7 _H (CM)	1	1	1	0	1	1	0 0
1F6 _H (DH)	x	x	x	DV	xx		
1F5 _H (CH)	xx						
1F4 _H (CL)	xx						
1F3 _H (SN)	xx						
1F2 _H (SC)	xx						
1F1 _H (FR)	xx						

At command completion (I/O registers contents to be read)							
1F7 _H (ST)	Status information						
1F6 _H (DH)	x	x	x	DV	xx		
1F5 _H (CH)	xx						
1F4 _H (CL)	xx						
1F3 _H (SN)	xx						
1F2 _H (SC)	xx						
1F1 _H (ER)	Error information						

(27) IDENTIFY DEVICE DMA (X'EE')

When this command is not used to transfer data to the host in DMA mode, this command functions in the same way as the Identify Device command.

At command issuance (I/O registers setting contents)							
1F7 _H (CM)	1	1	1	0	1	1	0
1F6 _H (DH)	x	x	x	DV	xx		
1F5 _H (CH)	xx						
1F4 _H (CL)	xx						
1F3 _H (SN)	xx						
1F2 _H (SC)	xx						
1F1 _H (FR)	xx						

At command completion (I/O registers contents to be read)							
1F7 _H (ST)	Status information						
1F6 _H (DH)	x	x	x	DV	xx		
1F5 _H (CH)	xx						
1F4 _H (CL)	xx						
1F3 _H (SN)	xx						
1F2 _H (SC)	xx						
1F1 _H (ER)	Error information						

Table 5.22 Information to be read by IDENTIFY DEVICE command (1 of 2)

Word	Value	Description
0	X'045A'	General Configuration *1
1	X'3FFF'	Number of Logical cylinders *2
2	X'xxxx'	Detailed Configuration *3
3	X'10'	Number of Logical Heads *2
4-5	X'0000'	Undefined
6	X'3F'	Number of Logical sectors per Logical track *2
7-9	X'0000'	Undefined
10-19	Set by a device	Serial number (ASCII code, 20 characters, right)
20	X'0003'	Undefined
21	X'xxxx'	Buffer Size (1 LSB: 512 Bytes) ex. Buffer Size=8MBytes: X'4000'
22	X'0000'	Reserved
23-26	–	Firmware revision (ASCII code, 8 characters, left)
27-46	Set by a device	Model name (ASCII code, 40 characters, left)
47	X'8010'	Maximum number of sectors per interrupt on READ/WRITE MULTIPLE command
48	X'0000'	Reserved
49	X'2B00'	Capabilities *4
50	X'400x'	Capabilities *5
51	X'0200'	PIO data transfer mode *6
52	X'0200'	Reserved
53	X'0007'	Enable/disable setting of words 54-58 and 64-70, 88 *7
54	(Variable)	Number of current Cylinders
55	(Variable)	Number of current Head
56	(Variable)	Number of current sectors per track
57-58	(Variable)	Total number of current sectors
59	*8	Transfer sector count currently set by READ/WRITE MULTIPLE command *8
60-61	*2	Total number of user addressable sectors (LBA mode only) *2
62	X'0000'	Reserved
63	X'xx07'	Multiword DMA transfer mode *9
64	X'0003'	Advance PIO transfer mode support status *10

Table 5.22 Information to be read by IDENTIFY DEVICE command (2 of 2)

Word	Value	Description
65	X'0078'	Minimum multiword DMA transfer cycle time per word: 120 [ns]
66	X'0078'	Manufacturer's recommended DMA transfer cycle time: 120 [ns]
67	X'00F0'	Minimum PIO transfer cycle time without IORDY flow control: 240 [ns]
68	X'0078'	Minimum PIO transfer cycle time with IORDY flow control: 120 [ns]
69-79	X'0000'	Reserved
80	X'00FC'	Major version number *11
81	X'0021'	Minor version number
82	X'346B'	Support of command sets *12
83	X'5B29'	Support of command sets *13
84	X'40xx'	Support of command sets/function *14
85	*15	Valid of command sets/function *15
86	*16	Valid of command sets/function *16
87	*17	Default of command sets/function *17
88	X'xx3F'	Ultra DMA transfer mode *18
89	Set by a device	Security Erase Unit execution time (1 LSB: 2 min.) *19
90	X'0000'	Enhanced Security Erase Unit execution time (1 LSB: 2 min.)
91	(Variable)	Advance power management level
92	(Variable)	Master password revision
93	*20	Hardware configuration *20
94	(Variable)	Acoustic Management level *21
95-99	X'0000'	Reserved
100-103	X'xx'	Total number of sectors accessible by users in the 48-bit LBA mode *22
104-127	X'00'	Reserved
128	X'0xxx'	Security status *23
129-159	X'xxxx'	Undefined
160-254	X'0000'	Reserved
255	X'xxA5'	Check sum (The 2 complement of the lower order byte resulting from summing bits 7 to 0 of word 0 to 254 and word 255, in byte units.)

*1 Word 0: General configuration

Bit 15: ATA device = 0, ATAPI device = 1

- Bit 14-8: Undefined
- Bit 7: Removable disk drive = 1
- Bit 6: Fixed drive = 1
- Bit 5-3: Undefined
- Bit 2: IDENTIFY DEVICE Valid = 0
- Bit 1-0: Reserved

*2 Word 1, 3, 6, 60-61

Word	MHW2060AC	MHW2040AC
1	X ' 3FFF '	X ' 3FFF '
3	X ' 10 '	X ' 10 '
6	X ' 3F '	X ' 3F '
60-61	X ' 6FC7C80 '	X ' 4A85300 '

*3 Status of the Word 2 Identify information is shown as follows:

- 37C8h The device requires the SET FEATURES sub-command after the power-on sequence in order to spin-up. The Identify information is incomplete.
- 738Ch The device requires the SET FEATURES sub-command after the power-on sequence in order to spin-up. The Identify information is incomplete.
- 8C73h The device requires the SET FEATURES sub-command after the power-on sequence in order to spin-up. The Identify information is incomplete.
- C837h The device requires the SET FEATURES sub-command after the power-on sequence in order to spin-up. The Identify information is incomplete.
- Others Reserved

*4 Word 49: Capabilities

- Bit 15-14: Reserved
- Bit 13: 1 = Support the standby timer the same as the ATA standard.
- Bit 12: Reserved
- Bit 11: 1 = Supported
- Bit 10: 0 = Disable inhibition
- Bit 7-0: Undefined
- Bit 8: 1 = LBA Supported
- Bit 9: 1 = DMA Supported

-
- *5 Word 50: Device capability
 - Bit 15: 0
 - Bit 14: 1
 - Bit 13 to 1 Reserved
 - Bit 0 Standby timer value '1' = Standby timer value of the device is the smallest value.
 - *6 Word 51: PIO data transfer mode
 - Bit 15-8: PIO data transfer mode X'02'=PIO mode 2
 - Bit 7-0: Undefined
 - *7 Word 53: Enable/disable setting of word 54-58 and 64-70
 - Bit 15-3: Reserved
 - Bit 2: 1 = Enable the word 88
 - Bit 1: 1 = Enable the word 64-70
 - Bit 0: 1 = Enable the word 54-58
 - *8 Word 59: Transfer sector count currently set by READ/WRITE MULTIPLE command
 - Bit 15-9: Reserved
 - Bit 8: 1 = Enable the multiple sector transfer
 - Bit 7-0: Transfer sector count currently set by READ/WRITE MULTIPLE command without interrupt supports 2, 4, 8 and 16 sectors.
 - *9 Word 63: Multiword DMA transfer mode
 - Bit 15-11: Reserved
 - Bit 10: '1' = multiword DMA mode 2 is selected.
 - Bit 9: '1' = multiword DMA mode 1 is selected.
 - Bit 8: '1' = multiword DMA mode 0 is selected.
 - Bit 7-3: Reserved
 - Bit 2: 1 = Multiword DMA mode 2, 1, and 0 supported (Bit 1,0 = '1,1')
 - Bit 1: 1 = Multiword DMA mode 1, and 0 supported (Bit 0 = '1')
 - Bit 0: 1 = Mode 0

*10 Word 64: Advance PIO transfer mode support status

- Bit 15-8: Reserved
- Bit 7-0: Advance PIO transfer mode
- Bit 1: 1 = Mode 4 (Bit 0 = '1')
- Bit 0: 1 = Mode 3

*11 WORD 80

- Bit 15-8: Reserved
- Bit 7: 1 = ATA/ATAPI-7 supported
- Bit 6: 1 = ATA/ATAPI-6 supported
- Bit 5: 1 = ATA/ATAPI-5 supported
- Bit 4: 1 = ATA/ATAPI-4 supported
- Bit 3: 1 = ATA-3 supported
- Bit 2: 1 = ATA-2 supported
- Bit 1-0: Undefined

*12 WORD 82

- Bit 15: Undefined
- Bit 14: '1' = Supports the NOP command.
- Bit 13: '1' = Supports the READ BUFFER command.
- Bit 12: '1' = Supports the WRITE BUFFER command.
- Bit 11: Undefined
- Bit 10: '1' = Supports the Host Protected Area feature set.
- Bit 9: '1' = Supports the DEVICE RESET command.
- Bit 8: '1' = Supports the SERVICE interrupt.
- Bit 7: '1' = Supports the release interrupt.
- Bit 6: '1' = Supports the read cache function.
- Bit 5: '1' = Supports the write cache function.
- Bit 4: '1' = Supports the PACKET command feature set.
- Bit 3: '1' = Supports the power management feature set.
- Bit 2: '1' = Supports the Removable Media feature set.
- Bit 1: '1' = Supports the Security Mode feature set.
- Bit 0: '1' = Supports the SMART feature set.

***13 WORD 83**

- Bit 15: = 0
- Bit 14: = 1
- Bit 13: * '1' = FLUSH CACHE EXT command supported.
- Bit 12: '1' = FLUSH CACHE command supported.
- Bit 11: '1' = Device Configuration Overlay feature set supported.
- Bit 10:* '1' = 48 bit LBA feature set.
- Bit 9: '1' = Automatic Acoustic Management feature set.
- Bit 8: '1' = Supports the SET MAX Security extending command.
- Bit 7: Reserved
- Bit 6: '1' = When the power is turned on, spin is started by the SET FEATURES sub-command.
- Bit 5: '1' = Supports the Power-Up In Standby set.
- Bit 4: '1' = Supports the Removable Media Status Notification feature set.
- Bit 3: '1' = Supports the Advanced Power Management feature set.
- Bit 2: '1' = Supports the CFA (Compact Flash Association) feature set.
- Bit 1: '1' = Supports the READ/WRITE DMA QUEUED command.
- Bit 0: '1' = Supports the DOWNLOAD MICROCODE command.

*: Option (customizing)

***14 WORD 84**

- Bit 15: = 0
- Bit 14: = 1
- Bit 13: '1' = Supports the IDLE IMMEDIATE with UNLOAD FEATURE
- Bit 12-11: Reserved
- Bit 10: '1' = URG bit supported for WRITE STREAM DMA EXT and WRITE STREAM EXT
- Bit 9: '1' = URG bit supported for READ STREAM DMA EXT and READ STREAM EXT
- Bit 8: '1' = Supports the 64-bit World Wide Name
- Bit 7: '1' = Supports the WRITE DMA QUEUED FUA EXT command
- Bit 6: * '1' = Supports the WRITE DMA FUA EXT and WRITE MULTIPLE FUA EXT commands

- Bit 5: * '1' = Supports the General Purpose Logging feature set
- Bit 4: '1' = Supports the Streaming feature set
- Bit 3-2: Reserved
- Bit 1: '1' = Supports the SMART SELF-TEST.
- Bit 0: '1' = Supports the SMART Error Logging.

*: Option (customizing)

*15 WORD 85

- Bit 15: Undefined.
- Bit 14: '1' = Supports the NOP command.
- Bit 13: '1' = Supports the READ BUFFER command.
- Bit 12: '1' = Supports the WRITE BUFFER command.
- Bit 11: Undefined.
- Bit 10: '1' = Supports the Host Protected Area function.
- Bit 9: '1' = Supports the DEVICE RESET command.
- Bit 8: '1' = Enables the SERVICE interrupt. From the SET FEATURES command
- Bit 7: '1' = Enables the release interrupt. From the SET FEATURES command
- Bit 6: '1' = Enables the read cache function. From the SET FEATURES command
- Bit 5: '1' = Enables the write cache function.
- Bit 4: '1' = Enables the P PACKET command set.
- Bit 3: '1' = Supports the Power Management function.
- Bit 2: '1' = Supports the Removable Media function.
- Bit 1: '1' = From the SECURITY SET PASSWORD command
- Bit 0: '1' = From the SMART ENABLE OPERATION command

***16 WORD 86**

- Bit 15-14: Reserved
 - Bit 13: * '1' = FLUSH CACHE EXT command supported.
 - Bit 12: '1' = FLUSH CACHE command supported.
 - Bit 11: '1' = Device Configuration Overlay feature set supported.
 - Bit 10: * '1' = 48 bit LBA feature set.
 - Bit 9: '1' = Enables the Automatic Acoustic Management function.
From the SET FEATURES command
 - Bit 8: '1' = From the SET MAX SET PASSWORD command
 - Bit 7: Reserved
 - Bit 6: '1' = The SET FEATURES subcommand isn't necessary for Spin-up after power on.
 - Bit 5: '1' = Enables the Power-Up In Standby function.
 - Bit 4: '1' = Enables the Removable Media Status Notification function.
 - Bit 3: '1' = Enables the Advanced Power Management function.
 - Bit 2: '1' = Supports the CFA (Compact Flash Association) feature set.
 - Bit 1: * '1' = Supports the READ/WRITE DMA QUEUED command.
 - Bit 0: '1' = Supports the DOWNLOAD MICROCODE command.
- *: Option (customizing)

***17 WORD 87**

- Bit 15: = 0
- Bit 14: = 1
- Bit 13: '1' = Supports the IDLE IMMEDIATE with UNLOAD FEATURE
- Bit 12-11: Reserved
- Bit 10: '1' = URG bit supported for WRITE STREAM DMA EXT and WRITE STREAM EXT
- Bit 9: '1' = URG bit supported for READ STREAM DMA EXT and READ STREAM EXT
- Bit 8: '1' = Supports the 64-bit World Wide Name
- Bit 7: '1' = Supports the WRITE DMA QUEUED FUA EXT command
- Bit 6: * '1' = Supports the WRITE DMA FUA EXT and WRITE MULTIPLE FUA EXT commands
- Bit 5: * '1' = Supports the General Purpose Logging feature set

- Bit 4: '1' = Valid Configure Stream command has been executed
- Bit 3-2: Reserved
- Bit 1: '1' = Supports the SMART SELF-TEST.
- Bit 0: '1' = Supports the SMART Error Logging.

*18 WORD 88

- Bit 15-8: Currently used Ultra DMA transfer mode
 - Bit 13: '1' = Mode 5 is selected.
 - Bit 12: '1' = Mode 4 is selected.
 - Bit 11: '1' = Mode 3 is selected.
 - Bit 10: '1' = Mode 2 is selected.
 - Bit 9: '1' = Mode 1 is selected.
 - Bit 8: '1' = Mode 0 is selected.
- Bit 7-0: Supportable Ultra DMA transfer mode
 - Bit 5: '1' = Supports the Mode 5
 - Bit 4: '1' = Supports the Mode 4
 - Bit 3: '1' = Supports the Mode 3
 - Bit 2: '1' = Supports the Mode 2
 - Bit 1: '1' = Supports the Mode 1
 - Bit 0: '1' = Supports the Mode 0

*19 WORD 89 (Value × 2 minutes)

MHW2060AC = X'1E': 60 minutes

MHW2040AC = X'14': 40 minutes

*20 WORD 93

- Bits 15: = 0
- Bit 14: = '1'
- Bit 13: '1' = CBLID- is a higher level than VIH (80-conductor cable).
'0' = CBLID- is a lower level than VIL (40-conductor cable).

Bits 12-8: In the case of Device 1 (slave drive), a valid value is set.

Bit 12: Reserved

Bit 11: '1' = Device asserts PDIAG-.

Bit 10, 9: Method for deciding the device No. of Device 1.

'00' = Reserved

'01' = Using a jumper.

'10' = Using the CSEL signal.

'11' = Other method.

Bit 8: = '1' (In the case of device 1)

Bits 7-0: In the case of Device 0 (master drive), a valid value is set.

Bit 7: Reserved

Bit 6: '1' = Device 1 is selected, Device 0 responds.

Bit 5: '1' = Device 0, assertion of DASP- was detected.

Bit 4: '1' = Device 0, assertion of PDIAG- was detected.

Bit 3: '1' = Device 0, an error was not detected in the self-diagnosis.

Bit 2, 1: Method for deciding the device No. of Device 0.

'00' = Reserved

'01' = Using a jumper.

'10' = Using the CSEL signal.

'11' = Other method.

Bit 0: '1' = (In the case of device 0)

*21 WORD 94

Bit 15-8: X'FE' Recommended acoustic management value.

Bit 7-0: X'XX' Current set value.

FE-C0: Performance mode

BF-80: Acoustic mode

00: Acoustic management is unused it.
(It is same as "FE-CO")

*22 WORD 100-103

When "48 bit LBA" of the option (customize) is supported, same number of LBA as WORD 60-61 is displayed.

*23 WORD 128

- Bit 15-9: Reserved
- Bit 8: Security level. 0: High, 1: Maximum
- Bit 7-6: Reserved
- Bit 5: '1' = Enhanced security erase supported
- Bit 4: '1' = Security counter expired
- Bit 3: '1' = Security frozen
- Bit 2: '1' = Security locked
- Bit 1: '1' = Security enabled
- Bit 0: '1' = Security supported

(28) SET FEATURES (X'EF')

The host system issues the SET FEATURES command to set parameters in the Features register for the purpose of changing the device features to be executed.

Upon receipt of this command, the device sets the BSY bit of the Status register and saves the parameters in the Features register. Then, the device clears the BSY bit, and generates an interrupt.

If the value in the Features register is not supported or it is invalid, the device posts an ABORTED COMMAND error.

Table 5.23 lists the available values and operational modes that may be set in the Features register.

Table 5.23 Features register values and settable modes

Features Register	Drive operation mode
X'02'	Enables the write cache function.
X'03'	Set the data transfer mode. *1
X'05'	Enables the advanced power management function. *2
X'42'	Enables the Acoustic management function. *3
X'55'	Disables read cache function.
X'66'	Disables the reverting to power-on default settings after software reset. (*1)
X'82'	Disables the write cache function.
X'85'	Set the advanced power management mode to Mode-0.
X'AA'	Enables the read cache function.
X'BB'	Specifies the transfer of 4-byte ECC for READ LONG and WRITE LONG commands. (*1)
X'C2'	Disables the Acoustic management function.
X'CC'	Enables the reverting to power-on default settings after software reset. (*1)

*1 Although there is a response to the command, nothing is done.

At power-on or after hardware reset, the default mode is set as follows.

Write cache function	: Enabled
Transfer mode	: PIO Mode-4, Multiword DMA Mode-2
Advanced power management function	: Enabled (Mode-1)
Acoustic management function	: State keeping
Read cache function	: Enabled

At command issuance (I/O registers setting contents)							
1F7 _H (CM)	1	1	1	0	1	1	1
1F6 _H (DH)	x	x	x	DV	xx		
1F5 _H (CH)	xx						
1F4 _H (CL)	xx						
1F3 _H (SN)	xx						
1F2 _H (SC)	xx or *1~3						
1F1 _H (FR)	[See Table 5.5]						

At command completion (I/O registers contents to be read)					
1F7 _H (ST)	Status information				
1F6 _H (DH)	x	x	x	DV	xx
1F5 _H (CH)	xx				
1F4 _H (CL)	xx				
1F3 _H (SN)	xx				
1F2 _H (SC)	xx				
1F1 _H (ER)	Error information				

*1) Data Transfer Mode

The host sets X'03' to the Features register. By issuing this command with setting a value to the Sector Count register, the transfer mode can be selected. Upper 5 bits of the Sector Count register defines the transfer type and lower 3 bits specifies the binary mode value.

The IDD supports following values in the Sector Count register value. If other value than below is specified, an ABORTED COMMAND error is posted.

PIO default transfer mode	00000 000 (X'00')
PIO flow control transfer mode X	00001 000 (X'08': Mode 0)
	00001 001 (X'09': Mode 1)
	00001 010 (X'0A': Mode 2)
	00001 011 (X'0B': Mode 3)
	00001 100 (X'0C': Mode 4)

Multiword DMA transfer mode X	00100 000 (X'20': Mode 0)
	00100 001 (X'21': Mode 1)
	00100 010 (X'22': Mode 2)
Ultra DMA transfer mode X	01000 000 (X'40': Mode 0)
	01000 001 (X'41': Mode 1)
	01000 010 (X'42': Mode 2)
	01000 011 (X'43': Mode 3)
	01000 100 (X'44': Mode 4)
	01000 101 (X'45': Mode 5)

*2) Advanced Power Management (APM)

The host writes the Sector Count register with the desired power management level and executes this command with the Features register X'05', and then Advanced Power Management is enabled.

The drive automatically shifts to power saving mode up to the specified APM level when the drive does not receive any commands for a specific time. The sequence in which the power management level shifts is from Active Idle to Low Power Idle to Standby. The Mode-2 level requires the longest shifting time, depending on the APM level settings. The settings of the APM level revert to their default values (Mode-1) when power-on or a hardware reset occurs for the drive.

APM Level	Sector Count Register
Mode 0 Active Idle → Low Power Idle	C0h-FEh
Mode 1 Active Idle → Low Power Idle	80h-BFh
Mode 2 Active Idle → Low Power Idle → Standby	01h-7Fh
Reserve (State Keep)	00h, FFh

Active Idle: The spindle motor rotates, and the head is loaded on the most inner position on media.

Low Power Idle: The spindle motor rotates, and the head is unloaded.

Standby: The spindle motor stops, and the head is unloaded.

***3) Automatic Acoustic Management (AAM)**

The host writes to the Sector Count register with the requested acoustic management level and executes this command with subcommand code 42h, and then Automatic Acoustic Management is enabled. The AAM level setting is preserved by the drive across power on, hardware and software resets.

AAM Level	Sector Count Register
Performance mode (Fast Seek)	C0h-FEh
Acoustic mode (Slow Seek)	80h-BFh
Abort	01h-7Fh
Non Operate	00h, FFh

High-speed seek to which gives priority to the performance operates as for "Performance mode", and low-speed seek by which the seek sound is suppressed operates as for "Acoustic mode".

Setting the seek mode by this command is applied to the seek operation in all command processing.

(29) SECURITY SET PASSWORD (X'F1')

This command enables a user password or master password to be set.

The host transfers the 512-byte data shown in Table 5.24 to the device. The device determines the operation of the lock function according to the specifications of the Identifier bit and Security level bit in the transferred data. (Table 5.25)

Issuing this command in LOCKED MODE or FROZEN MODE returns the Aborted Command error.

Table 5.24 Contents of SECURITY SET PASSWORD data

Word	Contents
0	Control word Bit 0 Identifier 0 = Sets a user password. 1 = Sets a master password. Bits 1 to 7 Reserved Bit 8 Security level 0 = High 1 = Maximum Bits 9 to 15 Reserved
1 to 16	Password (32 bytes)
17	Master password version number (Valid is Bit 0=1)
18 to 255	Reserved

Table 5.25 Relationship between combination of Identifier and Security level, and operation of the lock function

Identifier	Level	Description
User	High	The specified password is saved as a new user password. The lock function is enabled after the device is turned off and then on. LOCKED MODE can be canceled using the user password or the master password already set.
User	Maximum	The specified password is saved as a new user password. The lock function is enabled after the device is turned off and then on. LOCKED MODE can be canceled using the user password only. The master password already set cannot cancel LOCKED MODE.
Master	High or Maximum	The specified password is saved as a new master password. The lock function is not enabled.

At command issuance (I-O register contents)							
1F7 _h (CM)	1	1	1	1	0	0	1
1F6 _h (DH)	x	x	x	DV	xx		
1F5 _h (CH)	xx						
1F4 _h (CL)	xx						
1F3 _h (SN)	xx						
1F2 _h (SC)	xx						
1F1 _h (FR)	xx						

At command completion (I-O register contents)					
1F7 _h (ST)	Status information				
1F6 _h (DH)	x	x	x	DV	xx
1F5 _h (CH)	xx				
1F4 _h (CL)	xx				
1F3 _h (SN)	xx				
1F2 _h (SC)	xx				
1F1 _h (ER)	Error information				

(30) SECURITY UNLOCK(X'F2')

This command cancels LOCKED MODE.

The host transfers the 512-byte data shown in Table 5.26 to the device. Operation of the device varies as follows depending on whether the host specifies the master password.

- When the master password is selected

When the security level in LOCKED MODE is high, the password is compared with the master password already set. If the passwords are the same, LOCKED MODE is canceled. Otherwise, the Aborted Command error is returned. If the security level in LOCKED MODE is set to the highest level, the Aborted Command error is always returned.

- When the user password is selected

The password is compared with the user password already set. If the passwords are the same, LOCKED MODE is canceled. Otherwise, the Aborted Command error is returned.

If the password comparison fails, the device decrements the UNLOCK counter. The UNLOCK counter initially has a value of five. When the value of the UNLOCK counter reaches zero, this command or the SECURITY ERASE UNIT command causes the Aborted Command error until the device is turned off and then on, or until a hardware reset is executed. Issuing this command with LOCKED MODE canceled (in UNLOCK MODE) has no effect on the UNLOCK counter.

Issuing this command in FROZEN MODE returns the Aborted Command error.

At command issuance (I-O register contents)							
1F7 _h (CM)	1	1	1	1	0	0	1 0
1F6 _h (DH)	x	x	x	DV	xx		
1F5 _h (CH)	xx						
1F4 _h (CL)	xx						
1F3 _h (SN)	xx						
1F2 _h (SC)	xx						
1F1 _h (FR)	xx						

At command completion (I-O register contents)					
1F7 _h (ST)	Status information				
1F6 _h (DH)	x	x	x	DV	xx
1F5 _h (CH)	xx				
1F4 _h (CL)	xx				
1F3 _h (SN)	xx				
1F2 _h (SC)	xx				
1F1 _h (ER)	Error information				

(31) SECURITY ERASE PREPARE (X'F3')

The SECURITY ERASE UNIT command feature is enabled by issuing the SECURITY ERASE PREPARE command and then the SECURITY ERASE UNIT command. The SECURITY ERASE PREPARE command prevents data from being erased unnecessarily by the SECURITY ERASE UNIT command.

Issuing this command during FROZEN MODE returns the Aborted Command error.

At command issuance (I-O register contents)							
1F7 _h (CM)	1	1	1	1	0	0	1 1
1F6 _h (DH)	x	x	x	DV	xx		
1F5 _h (CH)	xx						
1F4 _h (CL)	xx						
1F3 _h (SN)	xx						
1F2 _h (SC)	xx						
1F1 _h (FR)	xx						

At command completion (I-O register contents)							
1F7 _h (ST)	Status information						
1F6 _h (DH)	x	x	x	DV	xx		
1F5 _h (CH)	xx						
1F4 _h (CL)	xx						
1F3 _h (SN)	xx						
1F2 _h (SC)	xx						
1F1 _h (ER)	Error information						

(32) SECURITY ERASE UNIT (X'F4')

This command erases all user data. This command also invalidates the user password and releases the lock function.

The host transfers the 512-byte data shown in Table 5.26 to the device. The device compares the user password or master password in the transferred data with the user password or master password already set. The device erases user data, invalidates the user password, and releases the lock function if the passwords are the same.

Although this command invalidates the user password, the master password is retained. To recover the master password, issue the SECURITY SET PASSWORD command and reset the user password.

If the SECURITY ERASE PREPARE command is not issued immediately before this command is issued, the Aborted Command error is returned.

Issuing this command while in FROZEN MODE returns the Aborted Command error.

At command issuance (I-O register contents)						
1F7 _h (CM)	1	1	1	1	0	1 0 0
1F6 _h (DH)	x	x	x	DV	xx	
1F5 _h (CH)	xx					
1F4 _h (CL)	xx					
1F3 _h (SN)	xx					
1F2 _h (SC)	xx					
1F1 _h (FR)	xx					

At command completion (I-O register contents)						
1F7 _h (ST)	Status information					
1F6 _h (DH)	x	x	x	DV	xx	
1F5 _h (CH)	xx					
1F4 _h (CL)	xx					
1F3 _h (SN)	xx					
1F2 _h (SC)	xx					
1F1 _h (ER)	Error information					

(33) SECURITY FREEZE LOCK (X'F5')

This command puts the device into FROZEN MODE. The following commands used to change the lock function return the Aborted Command error if the device is in FROZEN MODE.

- SECURITY SET PASSWORD
- SECURITY UNLOCK
- SECURITY ERASE PREPARE
- SECURITY ERASE UNIT
- SECURITY DISABLE PASSWORD

FROZEN MODE is canceled when the power is turned off, or when hardware is resented. If this command is reissued in FROZEN MODE, the command is completed and FROZEN MODE remains unchanged.

Issuing this command during LOCKED MODE returns the Aborted Command error.

The following medium access commands return the Aborted Command error when the device is in LOCKED MODE:

- EREAD SECTORS (EXT)
- WRITE SECTORS (EXT)
- WRITE VERIFY
- READ VERIFY SECTORS (EXT)
- READ MULTIPLE (EXT)
- WRITE MULTIPLE (EXT/FUA EXT)
- READ DMA (EXT)
- WRITE DMA (EXT/FUA EXT)
- DEVICE CONFIGURAION RESTORE
- DEVICE CONFIGURAION SET
- SECURITY SET PASSWORD
- SECURITY FREEZE LOCK
- SECURITY DISABLE PASSWORD
- FLUSH CACHE (EXT)
- SET MAX ADDRESS (EXT)

At command issuance (I-O register contents)						
1F7 _h (CM)	1	1	1	1	0	1 0 1
1F6 _h (DH)	x	x	x	DV	xx	
1F5 _h (CH)	xx					
1F4 _h (CL)	xx					
1F3 _h (SN)	xx					
1F2 _h (SC)	xx					
1F1 _h (FR)	xx					

At command completion (I-O register contents)						
1F7 _h (ST)	Status information					
1F6 _h (DH)	x	x	x	DV	xx	
1F5 _h (CH)	xx					
1F4 _h (CL)	xx					
1F3 _h (SN)	xx					
1F2 _h (SC)	xx					
1F1 _h (ER)	Error information					

(34) SECURITY DISABLE PASSWORD (X'F6')

This command invalidates the user password already set and releases the lock function.

The host transfers the 512-byte data shown in Table 5.26 to the device. The device compares the user password or master password in the transferred data with the user password or master password already set, and releases the lock function if the passwords are the same.

Although this command invalidates the user password, the master password is retained. To recover the master password, issue the SECURITY SET PASSWORD command and reset the user password.

If the user password or master password transferred from the host does not match, the Aborted Command error is returned.

Issuing this command while in LOCKED MODE or FROZEN MODE returns the Aborted Command error.

(The section about the SECURITY FREEZE LOCK command describes LOCKED MODE and FROZEN MODE.)

Table 5.26 Contents of security password

Word	Contents
0	Control word Bit 0: Identifier 0 = Compares the user passwords. 1 = Compares the master passwords. Bits 1 to 15: Reserved
1 to 16	Password (32 bytes)
17 to 255	Reserved

At command issuance (I-O register contents))								
1F7 _h (CM)	1	1	1	1	0	1	1	0
1F6 _h (DH)	x	x	x	DV	xx			
1F5 _h (CH)	xx							
1F4 _h (CL)	xx							
1F3 _h (SN)	xx							
1F2 _h (SC)	xx							
1F1 _h (FR)	xx							

At command completion (I-O register contents)					
1F7 _h (ST)	Status information				
1F6 _h (DH)	x	x	x	DV	xx
1F5 _h (CH)	xx				
1F4 _h (CL)	xx				
1F3 _h (SN)	xx				
1F2 _h (SC)	xx				
1F1 _h (ER)	Error information				

(35) READ NATIVE MAX ADDRESS (X'F8')

This command posts the maximum address intrinsic to the device, which can be set by the SET MAX ADDRESS command. Upon receipt of this command, the device sets the BSY bit and indicates the maximum address in the DH, CH, CL and SN registers. Then, it clears BSY and generates an interrupt.

At command issuance (I/O registers setting contents)							
1F7 _H (CM)	1	1	1	1	1	0	0
1F6 _H (DH)	x	L	x	DV	xx		
1F5 _H (CH)	xx						
1F4 _H (CL)	xx						
1F3 _H (SN)	xx						
1F2 _H (SC)	xx						
1F1 _H (FR)	xx						

At command completion (I/O registers contents to be read)					
1F7 _H (ST)	Status information				
1F6 _H (DH)	x	x	x	DV	Max head/LBA [MSB]
1F5 _H (CH)	Max. cylinder [MSB]/Max. LBA				
1F4 _H (CL)	Max. cylinder [LSB]/Max. LBA				
1F3 _H (SN)	Max. sector/Max. LBA [LSB]				
1F2 _H (SC)	xx				
1F1 _H (ER)	Error information				

(36) SET MAX (X'F9')

SET MAX features register values

Value	Command
00h	Obsolete
01h	SET MAX SET PASSWORD
02h	SET MAX LOCK
03h	SET MAX UNLOCK
04h	SET MAX FREEZE LOCK
05h - FFh	Reserved

- **SET MAX ADDRESS**

A successful READ NATIVE MAX ADDRESS command shall immediately precede a SET MAX ADDRESS command.

This command allows the maximum address accessible by the user to be set in LBA or CHS mode. Upon receipt of the command, the device sets the BSY bit and saves the maximum address specified in the DH, CH, CL and SN registers. Then, it clears BSY and generates an interrupt.

The new address information set by this command is reflected in Words 1, 54, 57, 58, 60 and 61 of IDENTIFY DEVICE information. If an attempt is made to perform a read or write operation for an address beyond the new address space, an ID Not Found error will result.

When SC register bit 0, VV (Value Volatile), is 1, the value set by this command is held even after power on and the occurrence of a hard reset. When the VV bit is 0, the value set by this command becomes invalid when the power is turned on or a hard reset occurs, and the maximum address returns to the value most lately set when VV bit = 1. (The value by VV bit = 0 is held in case that this command with VV bit = 1 has not been issued or had set the default value, and hard reset occurs.)

After power on and the occurrence of a hard reset, the host can issue this command only once when VV bit = 1. If this command with VV bit = 1 is issued twice or more, any command following the first time will result in an Aborted Command error.

When the SET MAX ADDRESS EXT command is executed, all SET MAX ADDRESS commands are aborted. The address value returns to the origin when the SET MAX ADDRESS EXT command is executed using the address value returned by the READ NATIVE MAX ADDRESS command.

At command issuance (I/O registers setting contents)								
1F7 _H (CM)	1	1	1	1	1	0	0	1
1F6 _H (DH)	x	L	x	DV	Max head/LBA [MSB]			
1F5 _H (CH)	Max. cylinder [MSB]/Max. LBA							
1F4 _H (CL)	Max. cylinder [LSB]/Max. LBA							
1F3 _H (SN)	Max. sector/Max. LBA [LSB]							
1F2 _H (SC)	xx						VV	
1F1 _H (FR)	xx							

At command completion (I/O registers contents to be read)							
1F7 _H (ST)	Status information						
1F6 _H (DH)	x	x	x	DV	Max head/LBA [MSB]		
1F5 _H (CH)	Max. cylinder [MSB]/Max. LBA						
1F4 _H (CL)	Max. cylinder [LSB]/Max. LBA						
1F3 _H (SN)	Max. sector/Max. LBA [LSB]						
1F2 _H (SC)	xx						
1F1 _H (ER)	Error information						

- SET MAX SET PASSWORD (FR = 01h)

This command requests a transfer of 1 sector of data from the host, and defines the contents of SET MAX password. The password is retained by the device until the next power cycle.

The READ NATIVE MAX ADDRESS command is not executed just before this command. The command is the SET MAX ADDRESS command if it is the command just after the READ NATIVE MAX ADDRESS command is executed.

At command issuance (I/O registers setting contents)								
1F7 _H (CM)	1	1	1	1	1	0	0	1
1F6 _H (DH)	x	x	x	DV	xx			
1F5 _H (CH)	xx							
1F4 _H (CL)	xx							
1F3 _H (SN)	xx							
1F2 _H (SC)	xx							
1F1 _H (FR)	01							

At command completion (I/O registers contents to be read)	
1F7 _H (ST)	Status information
1F6 _H (DH)	xx
1F5 _H (CH)	xx
1F4 _H (CL)	xx
1F3 _H (SN)	xx
1F2 _H (SC)	xx
1F1 _H (ER)	Error information

Password information

Words	Contents
0	Reserved
1 to 16	Password (32 bytes)
17 to 255	Reserved

- SET MAX LOCK (FR = 02h)

The SET MAX LOCK command sets the device into SET_MAX_LOCK state.

After this command is completed, any other SET MAX commands except SET MAX UNLOCK and SET MAX FREEZE LOCK commands are rejected. And the device returns command aborted.

The device remains in the SET MAX LOCK state until a power cycle or the acceptance of SET MAX UNLOCK or SET MAX FREEZE LOCK command.

The READ NATIVE MAX ADDRESS command is not executed just before this command. The command is the SET MAX ADDRESS command if it is the command just after the READ NATIVE MAX ADDRESS command is executed.

At command issuance (I/O registers setting contents)								
1F7 _H (CM)	1	1	1	1	1	0	0	1
1F6 _H (DH)	x	x	x	DV	xx			
1F5 _H (CH)	xx							
1F4 _H (CL)	xx							
1F3 _H (SN)	xx							
1F2 _H (SC)	xx							
1F1 _H (FR)	02							

At command completion (I/O registers contents to be read)	
1F7 _H (ST)	Status information
1F6 _H (DH)	xx
1F5 _H (CH)	xx
1F4 _H (CL)	xx
1F3 _H (SN)	xx
1F2 _H (SC)	xx
1F1 _H (ER)	Error information

- **SET MAX UNLOCK (FR = 03h)**

This command requests a transfer of single sector of data from the host, and defines the contents of SET MAX ADDRESS password.

The password supplied in the sector of data transferred shall be compared with the stored password.

If the password compare fails, the device returns command aborted and decrements the Unlock counter, and remains in the Set Max Lock state. On the acceptance of the SET MAX LOCK command, the Unlock counter is set to a value of five. When this counter reaches zero, then SET MAX UNLOCK command returns command aborted until a power cycle.

If the password compare matches, then the device makes a transition to the Set Max Unlocked state and all SET MAX commands will be accepted.

The READ NATIVE MAX ADDRESS command is not executed just before this command. The command is the SET MAX ADDRESS command if it is the command just after the READ NATIVE MAX ADDRESS command is executed.

At command issuance (I/O registers setting contents)								
1F7 _H (CM)	1	1	1	1	1	0	0	1
1F6 _H (DH)	x	x	x	DV	xx			
1F5 _H (CH)	xx							
1F4 _H (CL)	xx							
1F3 _H (SN)	xx							
1F2 _H (SC)	xx							
1F1 _H (FR)	03							

At command completion (I/O registers contents to be read)	
1F7 _H (ST)	Status information
1F6 _H (DH)	xx
1F5 _H (CH)	xx
1F4 _H (CL)	xx
1F3 _H (SN)	xx
1F2 _H (SC)	xx
1F1 _H (ER)	Error information

- **SET MAX FREEZE LOCK (FR = 04h)**

The Set MAX FREEZE LOCK command sets the device to SET_MAX_Frozen state.

After the device made a transition to the Set Max Freeze Lock state, the following SET MAX commands are rejected, then the device returns command aborted:

- SET MAX ADDRESS
- SET MAX SET PASSWORD
- SET MAX LOCK
- SET MAX UNLOCK

If the Device is in the SET_MAX_UNLOCK state with the SET MAX FREEZE LOCK command, then the device returns command aborted.

The READ NATIVE MAX ADDRESS command is not executed just before this command. The command is the SET MAX ADDRESS command if it is the command just after the READ NATIVE MAX ADDRESS command is executed.

At command issuance (I/O registers setting contents)								
1F7 _H (CM)	1	1	1	1	1	0	0	1
1F6 _H (DH)	x	x	x	DV	xx			
1F5 _H (CH)	xx							
1F4 _H (CL)	xx							
1F3 _H (SN)	xx							
1F2 _H (SC)	xx							
1F1 _H (FR)	04							

At command completion (I/O registers contents to be read)	
1F7 _H (ST)	Status information
1F6 _H (DH)	xx
1F5 _H (CH)	xx
1F4 _H (CL)	xx
1F3 _H (SN)	xx
1F2 _H (SC)	xx
1F1 _H (ER)	Error information

(37) READ SECTOR(S) EXT (X'24'): Option (customizing)

- Description

This command is the extended command of the READ SECTOR(S) command. The LBA specification is increased from 28 bits to 48 bits, and the maximum number of sectors that can be transferred by a single command is changed from 100h to 10000h. Other command controls are the same as those of the READ SECTOR(S) command.

At command issuance (I/O registers setting contents)						
1F7 _h (CM)	0	0	1	0	0	1 0 0
1F6 _h (DH)	1	L	1	DV	xx	
1F5 _h (CH) P	LBA (47-40)					
1F5 _h (CH) C	LBA (23-16)					
1F4 _h (CL) P	LBA (39-32)					
1F4 _h (CL) C	LBA (15-8)					
1F3 _h (SN) P	LBA (31-24)					
1F3 _h (SN) C	LBA (7-0)					
1F2 _h (SC) P	Sector count (15-8)					
1F2 _h (SC) C	Sector count (7-0)					
1F1 _h (FR) P	xx					
1F1 _h (FR) C	xx					

C: Current
P: Previous

At command completion (I/O registers contents to be read)						
1F7 _h (ST)	Status information					
1F6 _h (DH)	1	L	1	DV	xx	
1F5 _h (CH) 1	LBA (47-40)					
1F5 _h (CH) 0	LBA (23-16)					
1F4 _h (CL) 1	LBA (39-32)					
1F4 _h (CL) 0	LBA (15-8)					
1F3 _h (SN) 1	LBA (31-24)					
1F3 _h (SN) 0	LBA (7-0)					
1F2 _h (SC) 1	xx					
1F2 _h (SC) 0	xx					
1F1 _h (ER)	Error information					

0: HOB=0
1: HOB=1

(38) READ DMA EXT (X'25'): Option (customizing)

- Description

This command is the extended command of the READ DMA command. The LBA specification is increased from 28 bits to 48 bits, and the maximum number of sectors that can be transferred by a single command is changed from 100h to 10000h. Other command controls are the same as those of the READ DMA command.

At command issuance (I/O registers setting contents)						
1F7 _h (CM)	0	0	1	0	0	1 0 1
1F6 _h (DH)	1	L	1	DV	xx	
1F5 _h (CH) P	LBA (47-40)					
1F5 _h (CH) C	LBA (23-16)					
1F4 _h (CL) P	LBA (39-32)					
1F4 _h (CL) C	LBA (15-8)					
1F3 _h (SN) P	LBA (31-24)					
1F3 _h (SN) C	LBA (7-0)					
1F2 _h (SC) P	Sector count (15-8)					
1F2 _h (SC) C	Sector count (7-0)					
1F1 _h (FR) P	xx					
1F1 _h (FR) C	xx					

C: Current
P: Previous

At command completion (I/O registers contents to be read)						
1F7 _h (ST)	Status information					
1F6 _h (DH)	1	L	1	DV	xx	
1F5 _h (CH) 1	LBA (47-40)					
1F5 _h (CH) 0	LBA (23-16)					
1F4 _h (CL) 1	LBA (39-32)					
1F4 _h (CL) 0	LBA (15-8)					
1F3 _h (SN) 1	LBA (31-24)					
1F3 _h (SN) 0	LBA (7-0)					
1F2 _h (SC) 1	xx					
1F2 _h (SC) 0	xx					
1F1 _h (ER)	Error information					

0: HOB=0
1: HOB=1

(39) READ NATIVE MAX ADDRESS EXT (X'27'): Option (customizing)

- Description

This command is used to assign the highest address that the device can initially set with the SET MAX ADDRESS EXT command. The maximum address is displayed in the CH, CL, SN registers of the device control register with HOB bit = 0, 1.

- Error reporting conditions

This command is issued with LBA = 0. (ST = 51h, ER= 04h: Aborted command)

At command issuance (I/O registers setting contents)						
1F7 _h (CM)	0	0	1	0	0	1 1 1
1F6 _h (DH)	1	L	1	DV	xx	
1F5 _h (CH) P	xx					
1F5 _h (CH) C	xx					
1F4 _h (CL) P	xx					
1F4 _h (CL) C	xx					
1F3 _h (SN) P	xx					
1F3 _h (SN) C	xx					
1F2 _h (SC) P	xx					
1F2 _h (SC) C	xx					
1F1 _h (FR) P	xx					
1F1 _h (FR) C	xx					

C: Current
P: Previous

At command completion (I/O registers contents to be read)						
1F7 _h (ST)	Status information					
1F6 _h (DH)	1	L	1	DV	xx	
1F5 _h (CH) 1	Native max address LBA (47-40)					
1F5 _h (CH) 0	Native max address LBA (23-16)					
1F4 _h (CL) 1	Native max address LBA (39-32)					
1F4 _h (CL) 0	Native max address LBA (15-8)					
1F3 _h (SN) 1	Native max address LBA (31-24)					
1F3 _h (SN) 0	Native max address LBA (7-0)					
1F2 _h (SC) 1	xx					
1F2 _h (SC) 0	xx					
1F1 _h (ER)	Error information					

0: HOB=0
1: HOB=1

(40) READ MULTIPLE EXT (X'29'): Option (customizing)

- Description

This command is the extended command of the READ MULTIPLE command. The LBA specification is increased from 28 bits to 48 bits, and the maximum number of sectors that can be transferred by a single command is changed from 100h to 10000h. Other command controls are the same as those of the READ MULTIPLE command.

At command issuance (I/O registers setting contents)						
1F7 _h (CM)	0	0	1	0	1	0 0 1
1F6 _h (DH)	1	L	1	DV	xx	
1F5 _h (CH) P	LBA (47-40)					
1F5 _h (CH) C	LBA (23-16)					
1F4 _h (CL) P	LBA (39-32)					
1F4 _h (CL) C	LBA (15-8)					
1F3 _h (SN) P	LBA (31-24)					
1F3 _h (SN) C	LBA (7-0)					
1F2 _h (SC) P	Sector count (15-8)					
1F2 _h (SC) C	Sector count (7-0)					
1F1 _h (FR) P	xx					
1F1 _h (FR) C	xx					

C: Current
P: Previous

At command completion (I/O registers contents to be read)						
1F7 _h (ST)	Status information					
1F6 _h (DH)	1	L	1	DV	xx	
1F5 _h (CH) 1	LBA (47-40)					
1F5 _h (CH) 0	LBA (23-16)					
1F4 _h (CL) 1	LBA (39-32)					
1F4 _h (CL) 0	LBA (15-8)					
1F3 _h (SN) 1	LBA (31-24)					
1F3 _h (SN) 0	LBA (7-0)					
1F2 _h (SC) 1	xx					
1F2 _h (SC) 0	xx					
1F1 _h (ER)	Error information					

0: HOB=0
1: HOB=1

(41) READ LOG EXT (X'2F') [Optional command (Customize)]

- Description

This command reads data from the general-purpose log of a device. The general-purpose log includes the extended SMART comprehensive error log, extended self-test log, SMART selective self-test log, and other logs. The types of logs available depend on the customize operation. For information on the DRQ, INTRQ, and BSY protocols related to the transfer of data, see Section 5.4.1.

When command is issued (I/O register setting values)					
1F7H (CM)	0	0	1	0	1 1 1 1
1F6H (DH)	x	x	x	DV	xx
1F5H (CH) P	xx				
1F5H (CH) C	xx				
1F4H (CL) P	Sector offset (15-8)				
1F4H (CL) C	Sector offset (7-0)				
1F3H (SN) P	xx				
1F3H (SN) C	Log address				
1F2H (SC) P	Sector count (15-8)				
1F2H (SC) C	Sector count (7-0)				
1F1H (FR) P	xx				
1F1H (FR) C	xx				

C: Current
P: Previous

When command is completed (read data in I/O register)					
1F7 _H (ST)	Status information				
1F6 _H (DH)	x	x	x	DV	xx
1F5 _H (CH) 1	xx				
1F5 _H (CH) 0	xx				
1F4 _H (CL) 1	xx				
1F4 _H (CL) 0	xx				
1F3 _H (SN) 1	xx				
1F3 _H (SN) 0	xx				
1F2 _H (SC) 1	xx				
1F2 _H (SC) 0	xx				
1F1 _H (ER)	xx				

0: HOB=0
1: HOB=1

Log address: Log number of the log to be read
Sector offset: First log sector subject to the data transfer
Sector count: Number of sectors to be read from the specified log

If the device does not support this command, the device shall return the Command Aborted error.

If the Log address value, the Sector count value, or the Sector offset value is invalid, the device shall return the Command Aborted error.

(42) WRITE SECTOR(S) EXT (X'34'): Option (customizing)

- Description

This command is the extended command of the WRITE SECTOR (S) command. The LBA specification is increased from 28 bits to 48 bits, and the maximum number of sectors that can be transferred by a single command is changed from 100h to 10000h. Other command controls are the same as those of the WRITE SECTOR (S) command.

At command issuance (I/O registers setting contents)						
1F7 _h (CM)	0	0	1	1	0	1 0 0
1F6 _h (DH)	1	L	1	DV	xx	
1F5 _h (CH) P	LBA (47-40)					
1F5 _h (CH) C	LBA (23-16)					
1F4 _h (CL) P	LBA (39-32)					
1F4 _h (CL) C	LBA (15-8)					
1F3 _h (SN) P	LBA (31-24)					
1F3 _h (SN) C	LBA (7-0)					
1F2 _h (SC) P	Sector count (15-8)					
1F2 _h (SC) C	Sector count (7-0)					
1F1 _h (FR) P	xx					
1F1 _h (FR) C	xx					

C: Current
P: Previous

At command completion (I/O registers contents to be read)						
1F7 _h (ST)	Status information					
1F6 _h (DH)	1	L	1	DV	xx	
1F5 _h (CH) 1	LBA (47-40)					
1F5 _h (CH) 0	LBA (23-16)					
1F4 _h (CL) 1	LBA (39-32)					
1F4 _h (CL) 0	LBA (15-8)					
1F3 _h (SN) 1	LBA (31-24)					
1F3 _h (SN) 0	LBA (7-0)					
1F2 _h (SC) 1	xx					
1F2 _h (SC) 0	xx					
1F1 _h (ER)	Error information					

0: HOB=0
1: HOB=1

(43) WRITE DMA EXT (X'35'): Option (customizing)

- Description

This command is the extended command of the WRITE DMA command. The LBA specification is increased from 28 bits to 48 bits, and the maximum number of sectors that can be transferred by a single command is changed from 100h to 10000h. Other command controls are the same as those of the WRITE DMA command.

At command issuance (I/O registers setting contents)						
1F7 _h (CM)	0	0	1	1	0	1 0 1
1F6 _h (DH)	1	L	1	DV	xx	
1F5 _h (CH) P	LBA (47-40)					
1F5 _h (CH) C	LBA (23-16)					
1F4 _h (CL) P	LBA (39-32)					
1F4 _h (CL) C	LBA (15-8)					
1F3 _h (SN) P	LBA (31-24)					
1F3 _h (SN) C	LBA (7-0)					
1F2 _h (SC) P	Sector count (15-8)					
1F2 _h (SC) C	Sector count (7-0)					
1F1 _h (FR) P	xx					
1F1 _h (FR) C	xx					

C: Current
P: Previous

At command completion (I/O registers contents to be read)						
1F7 _h (ST)	Status information					
1F6 _h (DH)	1	L	1	DV	xx	
1F5 _h (CH) 1	LBA (47-40)					
1F5 _h (CH) 0	LBA (23-16)					
1F4 _h (CL) 1	LBA (39-32)					
1F4 _h (CL) 0	LBA (15-8)					
1F3 _h (SN) 1	LBA (31-24)					
1F3 _h (SN) 0	LBA (7-0)					
1F2 _h (SC) 1	xx					
1F2 _h (SC) 0	xx					
1F1 _h (ER)	Error information					

0: HOB=0
1: HOB=1

(44) SET MAX ADDRESS EXT (X'37'): Option (customizing)

- Description

This command limits specifications so that the highest address that can be accessed by users can be specified only in LBA mode.

The address information specified with this command is set in words 1, 54, 57, 58, 60, 61, and 100 to 103 of the IDENTIFY DEVICE command response. If read or write processing is executed for an address that is outside of the new address space, an ID Not Found error occurs.

If the SC register bit is 0 and the value volatile (VV) bit is 1 when this command is executed, the specified values are maintained after a power-on reset. If the VV bit is 0 when the command is executed, the specified values are invalidated during the power-on sequence. If the VV bit is 1, the highest address value is defined as the last value specified. (If the VV bit is not set to 1, the highest address is the default value.)

After a power-on reset is performed, a host can issue the SET MAX ADDRESS (EXT) command only once if the VV bit is 1. If the SET MAX ADDRESS (EXT) command is issued twice or more, an ID Not Found error occurs.

When the SET MAX ADDRESS EXT command is executed, all SET MAX ADDRESS commands are aborted. The address value returns to the origin when the SET MAX ADDRESS EXT command is executed using the address value returned by the READ NATIVE MAX ADDRESS command.

- Error reporting conditions

- This command is issued twice or more in an operation sequence. (ST = 51h, ER = 10h, ID Not Found)
- The READ NATIVE MAX ADDRESS EXT command (27h) is not issued immediately before this command (ST = 51h, ER = 04h, Aborted) is issued.
- This command is issued while LBA = 0 (ST = 51h, ER = 04h, Aborted)
- The SET MAX ADDRESS command has already been issued.

At command issuance (I/O registers setting contents)					
1F7 _h (CM)	0	0	1	1	0 1 1 1
1F6 _h (DH)	1	L	1	DV	xx
1F5 _h (CH) P	SET MAX LBA (47-40)				
1F5 _h (CH) C	SET MAX LBA (23-16)				
1F4 _h (CL) P	SET MAX LBA (39-32)				
1F4 _h (CL) C	SET MAX LBA (15-8)				
1F3 _h (SN) P	SET MAX LBA (31-24)				
1F3 _h (SN) C	SET MAX LBA (7-0)				
1F2 _h (SC) P	xx				
1F2 _h (SC) C	xx				VV
1F1 _h (FR) P	xx				
1F1 _h (FR) C	xx				

C: Current
P: Previous

At command completion (I/O registers contents to be read)					
1F7 _h (ST)	Status information				
1F6 _h (DH)	1	L	1	DV	xx
1F5 _h (CH) 1	SET MAX LBA (47-40)				
1F5 _h (CH) 0	SET MAX LBA (23-16)				
1F4 _h (CL) 1	SET MAX LBA (39-32)				
1F4 _h (CL) 0	SET MAX LBA (15-8)				
1F3 _h (SN) 1	SET MAX LBA (31-24)				
1F3 _h (SN) 0	SET MAX LBA (7-0)				
1F2 _h (SC) 1	xx				
1F2 _h (SC) 0	xx				
1F1 _h (ER)	Error information				

0: HOB=0
1: HOB=1

(45) WRITE MULTIPLE EXT (X'39'): Option (customizing)

- Description

This command is the extended command of the WRITE MULTIPLE command. The LBA specification is increased from 28 bits to 48 bits, and the maximum number of sectors that can be transferred by a single command is changed from 100h to 10000h. Other command controls are the same as those of the WRITE MULTIPLE command.

At command issuance (I/O registers setting contents)						
1F7 _h (CM)	0	0	1	1	1	0 0 1
1F6 _h (DH)	1	L	1	DV	xx	
1F5 _h (CH) P	LBA (47-40)					
1F5 _h (CH) C	LBA (23-16)					
1F4 _h (CL) P	LBA (39-32)					
1F4 _h (CL) C	LBA (15-8)					
1F3 _h (SN) P	LBA (31-24)					
1F3 _h (SN) C	LBA (7-0)					
1F2 _h (SC) P	Sector count (15-8)					
1F2 _h (SC) C	Sector count (7-0)					
1F1 _h (FR) P	xx					
1F1 _h (FR) C	xx					

C: Current
P: Previous

At command completion (I/O registers contents to be read)						
1F7 _h (ST)	Status information					
1F6 _h (DH)	1	L	1	DV	xx	
1F5 _h (CH) 1	LBA (47-40)					
1F5 _h (CH) 0	LBA (23-16)					
1F4 _h (CL) 1	LBA (39-32)					
1F4 _h (CL) 0	LBA (15-8)					
1F3 _h (SN) 1	LBA (31-24)					
1F3 _h (SN) 0	LBA (7-0)					
1F2 _h (SC) 1	xx					
1F2 _h (SC) 0	xx					
1F1 _h (ER)	Error information					

0: HOB=0
1: HOB=1

(46) WRITE DMA FUA EXT (X'3D'): Option (customizing)

- Description

The WRITE DMA FUA EXT command has the difference that reports on status after write to media is completed regardless of the setting of present Write cache though WRITE DMA EXT command and basic operation are the same.

At command issuance (I/O registers setting contents)						
1F7 _h (CM)	0	0	1	1	1	1 0 1
1F6 _h (DH)	1	L	1	DV	xx	
1F5 _h (CH) P	LBA (47-40)					
1F5 _h (CH) C	LBA (23-16)					
1F4 _h (CL) P	LBA (39-32)					
1F4 _h (CL) C	LBA (15-8)					
1F3 _h (SN) P	LBA (31-24)					
1F3 _h (SN) C	LBA (7-0)					
1F2 _h (SC) P	Sector count (15-8)					
1F2 _h (SC) C	Sector count (7-0)					
1F1 _h (FR) P	xx					
1F1 _h (FR) C	xx					

C: Current

P: Previous

At command completion (I/O registers contents to be read)						
1F7 _h (ST)	Status information					
1F6 _h (DH)	1	L	1	DV	xx	
1F5 _h (CH) 1	LBA (47-40)					
1F5 _h (CH) 0	LBA (23-16)					
1F4 _h (CL) 1	LBA (39-32)					
1F4 _h (CL) 0	LBA (15-8)					
1F3 _h (SN) 1	LBA (31-24)					
1F3 _h (SN) 0	LBA (7-0)					
1F2 _h (SC) 1	xx					
1F2 _h (SC) 0	xx					
1F1 _h (ER)	Error information					

0: HOB=0

1: HOB=1

(47) WRITE LOG EXT (X'3F') [Optional command (Customize)]

- Description

This command writes data to the general-purpose log of a device. The general-purpose log includes the extended SMART comprehensive error log, extended self-test log, SMART selective self-test log, and other logs. However, some of these logs are read-only logs. The types of logs available depend on the customize operation. For information on the DRQ, INTRQ, and BSY protocols related to the transfer of data, see Section 5.4.1.

When command is issued (I/O register setting values)								
1F7H (CM)	0	0	1	1	1	1	1	1
1F6H (DH)	x	x	x	DV	xx			
1F5H (CH) P	xx							
1F5H (CH) C	xx							
1F4H (CL) P	Sector offset (15-8)							
1F4H (CL) C	Sector offset (7-0)							
1F3H (SN) P	xx							
1F3H (SN) C	Log address							
1F2H (SC) P	Sector count (15-8)							
1F2H (SC) C	Sector count (7-0)							
1F1H (FR) P	xx							
1F1H (FR) C	xx							

C: Current
P: Previous

When command is completed (read data in I/O register)					
1F7 _H (ST)	Status information				
1F6 _H (DH)	x	x	x	DV	xx
1F5 _H (CH) 1	xx				
1F5 _H (CH) 0	xx				
1F4 _H (CL) 1	xx				
1F4 _H (CL) 0	xx				
1F3 _H (SN) 1	xx				
1F3 _H (SN) 0	xx				
1F2 _H (SC) 1	xx				
1F2 _H (SC) 0	xx				
1F1 _H (ER)	xx				

0: HOB=0
1: HOB=1

Log address: Log number of the log to be written
Sector offset: First log sector subject to the data transfer
Sector count: Number of sectors to be written to the specified log

If the device does not support this command, the device shall return the Command Aborted error.

If the Log address value, the Sector count value, or the Sector offset value is invalid, the device shall return the Command Aborted error.

(48) READ VERIFY SECTOR(S) EXT (X'42): Option (customizing)

- Description

This command is the extended command of the READ VERIFY SECTOR(S) command. The LBA specification is increased from 28 bits to 48 bits, and the maximum number of sectors that can be transferred by a single command is changed from 100h to 10000h. Other command controls are the same as those of the READ VERIFY SECTOR(S) command.

At command issuance (I/O registers setting contents)						
1F7 _h (CM)	0	1	0	0	0	0 1 0
1F6 _h (DH)	1	L	1	DV	xx	
1F5 _h (CH) P	LBA (47-40)					
1F5 _h (CH) C	LBA (23-16)					
1F4 _h (CL) P	LBA (39-32)					
1F4 _h (CL) C	LBA (15-8)					
1F3 _h (SN) P	LBA (31-24)					
1F3 _h (SN) C	LBA (7-0)					
1F2 _h (SC) P	Sector count (15-8)					
1F2 _h (SC) C	Sector count (7-0)					
1F1 _h (FR) P	xx					
1F1 _h (FR) C	xx					

C: Current
P: Previous

At command completion (I/O registers contents to be read)						
1F7 _h (ST)	Status information					
1F6 _h (DH)	1	L	1	DV	xx	
1F5 _h (CH) 1	LBA (47-40)					
1F5 _h (CH) 0	LBA (23-16)					
1F4 _h (CL) 1	LBA (39-32)					
1F4 _h (CL) 0	LBA (15-8)					
1F3 _h (SN) 1	LBA (31-24)					
1F3 _h (SN) 0	LBA (7-0)					
1F2 _h (SC) 1	xx					
1F2 _h (SC) 0	xx					
1F1 _h (ER)	Error information					

0: HOB=0
1: HOB=1

(49) WRITE MULTIPLE FUA EXT (X'CE'): Option (customizing)

- Description

The WRITE MULTIPLE FUA EXT command has the difference that reports on status after write to media is completed regardless of the setting of present Write cache though WRITE MULTIPLE EXT command and basic operation are the same.

At command issuance (I/O registers setting contents)						
1F7 _h (CM)	1	1	0	0	1	1 1 0
1F6 _h (DH)	1	L	1	DV	xx	
1F5 _h (CH) P	LBA (47-40)					
1F5 _h (CH) C	LBA (23-16)					
1F4 _h (CL) P	LBA (39-32)					
1F4 _h (CL) C	LBA (15-8)					
1F3 _h (SN) P	LBA (31-24)					
1F3 _h (SN) C	LBA (7-0)					
1F2 _h (SC) P	Sector count (15-8)					
1F2 _h (SC) C	Sector count (7-0)					
1F1 _h (FR) P	xx					
1F1 _h (FR) C	xx					

C: Current
P: Previous

At command completion (I/O registers contents to be read)						
1F7 _h (ST)	Status information					
1F6 _h (DH)	1	L	1	DV	xx	
1F5 _h (CH) 1	LBA (47-40)					
1F5 _h (CH) 0	LBA (23-16)					
1F4 _h (CL) 1	LBA (39-32)					
1F4 _h (CL) 0	LBA (15-8)					
1F3 _h (SN) 1	LBA (31-24)					
1F3 _h (SN) 0	LBA (7-0)					
1F2 _h (SC) 1	xx					
1F2 _h (SC) 0	xx					
1F1 _h (ER)	Error information					

0: HOB=0
1: HOB=1

(50) FLUSH CACHE EXT (X'EA'): Option (customizing)

- Description

This command executes the same operation as the Flush Cache command (E7h) but only LBA = 1 can be specified.

- Error reporting conditions

This command is issued with LBA = 0. (ST = 51h, ER= 10h: Aborted)

At command issuance (I/O registers setting contents)							
1F7 _h (CM)	1	1	1	0	1	0	1 0
1F6 _h (DH)	1	L	1	DV	xx		
1F5 _h (CH) P	xx						
1F5 _h (CH) C	xx						
1F4 _h (CL) P	xx						
1F4 _h (CL) C	xx						
1F3 _h (SN) P	xx						
1F3 _h (SN) C	xx						
1F2 _h (SC) P	xx						
1F2 _h (SC) C	xx						
1F1 _h (FR) P	xx						
1F1 _h (FR) C	xx						

C: Current
P: Previous

At command completion (I/O registers contents to be read)					
1F7 _h (ST)	Status information				
1F6 _h (DH)	1	L	1	DV	xx
1F5 _h (CH) 1	xx				
1F5 _h (CH) 0	xx				
1F4 _h (CL) 1	xx				
1F4 _h (CL) 0	xx				
1F3 _h (SN) 1	xx				
1F3 _h (SN) 0	xx				
1F2 _h (SC) 1	xx				
1F2 _h (SC) 0	xx				
1F1 _h (ER)	Error information				

0: HOB=0
1: HOB=1

5.3.3 Error posting

Table 5.27 lists the defined errors that are valid for each command.

Table 5.27 Command code and parameters (1 of 2)

COMMAND NAME	Error Register (X '1F1')					Status Register (X '1F7')		
	ICRC	UNC	IDNF	ABRT	TK0NF	DRDY	DWF	ERR
RECALIBRATE				V	V	V	V	V
READ SECTOR(S)		V	V	V		V	V	V
WRITE SECTOR(S)			V	V		V	V	V
WRITE VERIFY		V	V	V		V	V	V
READ VERIFY SECTOR(S)		V	V	V		V	V	V
SEEK			V	V		V	V	V
EXECUTE DEVICE DIAGNOSTIC	*1	*1	*1	*1	*1			
INITIALIZE DEVICE PARAMETERS				V		V	V	V
DOWNLOAD MICROCODE				V		V	V	V
STANDBY IMMEDIATE				V		V	V	V
IDLE (UNLOAD) IMMEDIATE				V		V	V	V
STANDBY				V		V	V	V
IDLE				V		V	V	V
CHECK POWER MODE				V		V	V	V
SLEEP				V		V	V	V
SMART			V	V		V	V	V
DEVICE CONFIGURATION				V		V	V	V
READ MULTIPLE		V	V	V		V	V	V
WRITE MULTIPLE			V	V		V	V	V
SET MULTIPLE MODE				V		V	V	V
READ DMA	V*2	V	V	V		V	V	V
WRITE DMA	V*2		V	V		V	V	V
READ BUFFER				V		V	V	V
FLUSH CACHE			V	V		V	V	V
WRITE BUFFER				V		V	V	V
IDENTIFY DEVICE				V		V	V	V
IDENTIFY DEVICE DMA				V		V	V	V
SET FEATURES				V		V	V	V
SECURITY SET PASSWORD				V		V	V	V
SECURITY UNLOCK				V		V	V	V
SECURITY ERASE PREPARE				V		V	V	V
SECURITY ERASE UNIT				V		V	V	V
SECURITY FREEZE LOCK				V		V	V	V
SECURITY DISABLE PASSWORD				V		V	V	V
READ NATIVE MAX ADDRESS				V		V	V	V
SET MAX			V	V		V	V	V

Table 5.27 Command code and parameters (2 of 2)

COMMAND NAME	Error Register (X '1F1')					Status Register (X '1F7')		
	ICRC	UNC	IDNF	ABRT	TKONF	DRDY	DWF	ERR
READ SECTOR(S) EXT *O		V	V	V		V	V	V
READ DMA EXT *O	V *2	V	V	V		V	V	V
READ NATIVE MAX ADDRESS EXT *O				V		V	V	V
READ MULTIPLE EXT *O		V	V	V		V	V	V
READ LOG EXT *O		V	V	V		V	V	V
WRITE SECTOR(S) EXT *O			V	V		V	V	V
WRITE DMA EXT *O	V *2		V	V		V	V	V
SET MAX ADDRESS EXT *O			V	V		V	V	V
WRITE MULTIPLE EXT *O			V	V		V	V	V
WRITE DMA FUA EXT *O	V *2		V	V		V	V	V
WRITE LOG EXT *O			V	V		V	V	V
READ VERIFY SECTOR(S) EXT *O		V	V	V		V	V	V
WRITE MULTIPLE FUA EXT *O			V	V		V	V	V
FLUSH CACHE EXT *O			V	V		V	V	V
INVALID COMMAND				V		V	V	V

- V: Valid on this command
*1: See the command descriptions.
*2: Valid only for Ultra DMA command.
*O: Option (customizing)

5.4 Command Protocol

The host should confirm that the BSY bit of the Status register of the device is 0 prior to issue a command. If BSY bit is 1, the host should wait for issuing a command until BSY bit is cleared to 0.

Commands can be executed only when the DRDY bit of the Status register is 1. However, the following commands can be executed even if DRDY bit is 0.

- EXECUTE DEVICE DIAGNOSTIC
- INITIALIZE DEVICE PARAMETERS

5.4.1 PIO Data transferring commands from device to host

The execution of the following commands involves data transfer from the device to the host.

- READ SECTOR (S) (EXT)
- SMART READ DATA
- SMART READ LOG
- DEVICE CONFIGURATION IDENTIFY
- READ BUFFER
- IDENTIFY DEVICE
- READ LOG EXT

The execution of these commands includes the transfer one or more sectors of data from the device to the host. Following shows the protocol outline.

- a) The host writes any required parameters to the Features, Sector Count, Sector Number, Cylinder, and Device/Head registers.
- b) The host writes a command code to the Command register.
- c) The device sets the BSY bit of the Status register and prepares for data transfer.
- d) When one sector of data is available for transfer to the host, the device sets DRQ bit and clears BSY bit. The drive then asserts INTRQ signal.
- e) After detecting the INTRQ signal assertion, the host reads the Status register. The host reads one sector of data via the Data register. In response to the Status register being read, the device negates the INTRQ signal.

- f) The drive clears DRQ bit to 0. If transfer of another sector is requested, the device sets the BSY bit and steps d) and after are repeated.

Even if an error is encountered, the device prepares for data transfer by setting the DRQ bit. Whether or not to transfer the data is determined for each host. In other words, the host should receive the relevant sector of data (512 bytes of uninsured dummy data) or release the DRQ status by resetting.

Figure 5.3 shows an example of READ SECTOR(S) command protocol, and Figure 5.4 shows an example protocol for command abort.

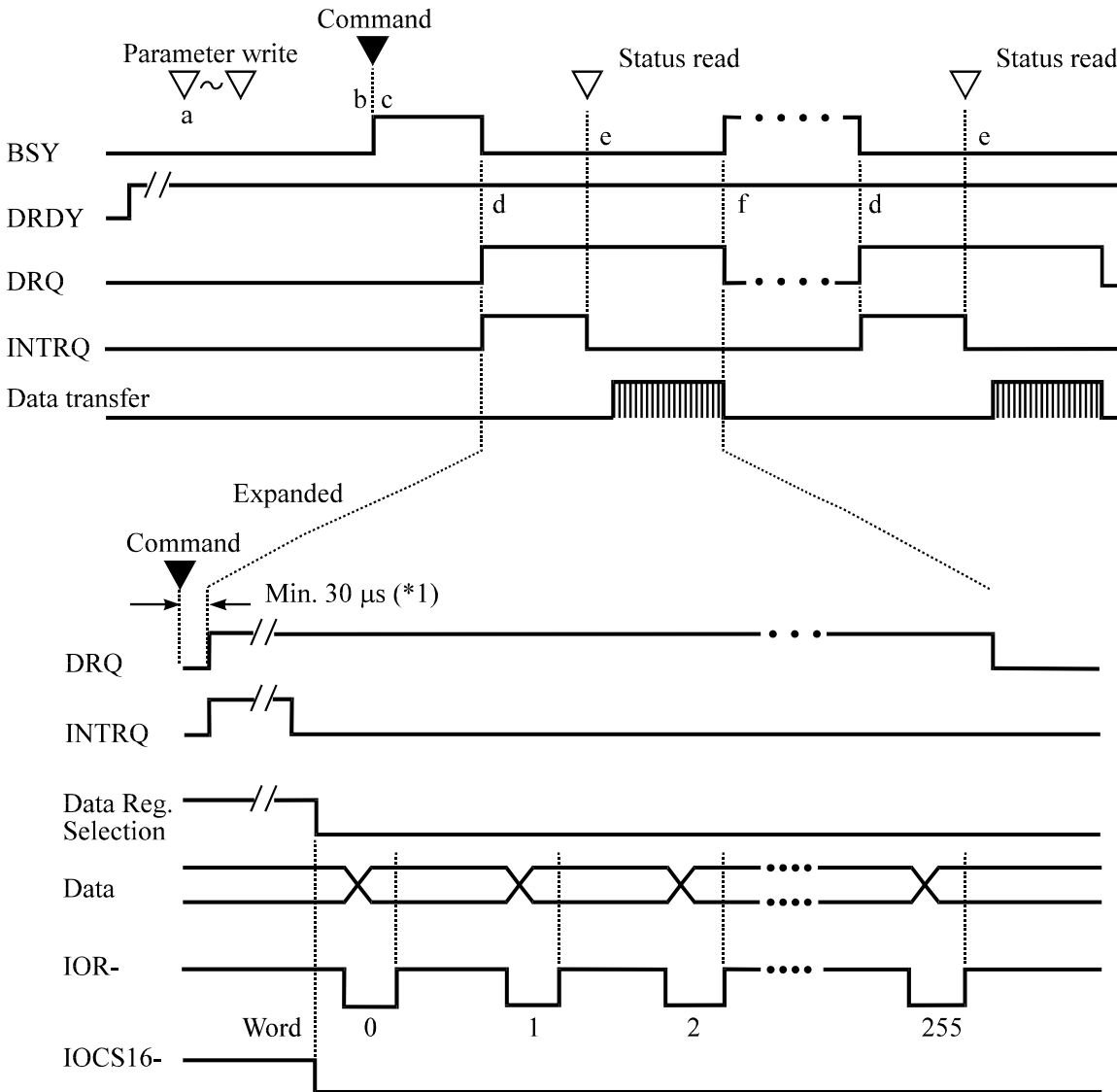

*1 When the IDD receives a command that hits the cache data during read-ahead, and transfers data from the buffer without reading from the disk medium.

Figure 5.3 READ SECTOR(S) COMMAND protocol

IMPORTANT

For transfer of a sector of data, the host needs to read Status register (X'1F7') in order to clear INTRQ (interrupt) signal. The Status register should be read within a period from the DRQ setting by the device to starting of the sector data transfer. Note that the host does not need to read the Status register for the reading of a single sector or the last sector in multiple-sector reading. If the timing to read the Status register does not meet above condition, normal data transfer operation is not guaranteed.

When the host new command even if the device requests the data transfer (setting in DRQ bit), the correct device operation is not guaranteed.

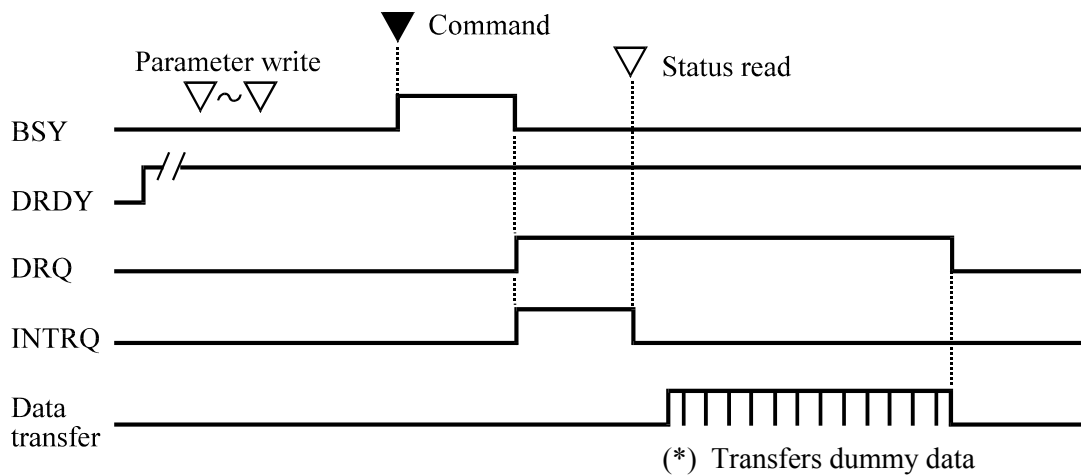

*: The host should receive 512-byte dummy data or release the DRQ set state by resetting.

Figure 5.4 Protocol for command abort

5.4.2 PIO Data transferring commands from host to device

The execution of the following commands involves Data transfer from the host to the drive.

- WRITE SECTOR(S) (EXT)
- WRITE VERIFY
- DOWNLOAD MICROCODE
- SMART WRITE LOG
- DEVICE OCNFIGURATION SET
- WRITE BUFFER
- SECURITY SET PASSWORD
- SECURITY UNCLOK
- SECURITY ERASE UNIT
- SECURITY DISABLE PASSWORD
- WRITE LOG EXT

The execution of these commands includes the transfer one or more sectors of data from the host to the device. Following shows the protocol outline.

- a) The host writes any required parameters to the Features, Sector Count, Sector Number, Cylinder, and Device/Head registers.
- b) The host writes a command code in the Command register. The drive sets the BSY bit of the Status register.
- c) When the device is ready to receive the data of the first sector, the device sets DRQ bit and clears BSY bit.
- d) The host writes one sector of data through the Data register.
- e) The device clears the DRQ bit and sets the BSY bit.
- f) When the drive completes transferring the data of the sector, the device clears BSY bit and asserts INTRQ signal. If transfer of another sector is requested, the drive sets the DRQ bit.
- g) After detecting the INTRQ signal assertion, the host reads the Status register.
- h) The device resets INTRQ (the interrupt signal).
- i) If transfer of another sector is requested, steps d) and after are repeated.

Figure 5.5 shows an example of WRITE SECTOR(S) command protocol.

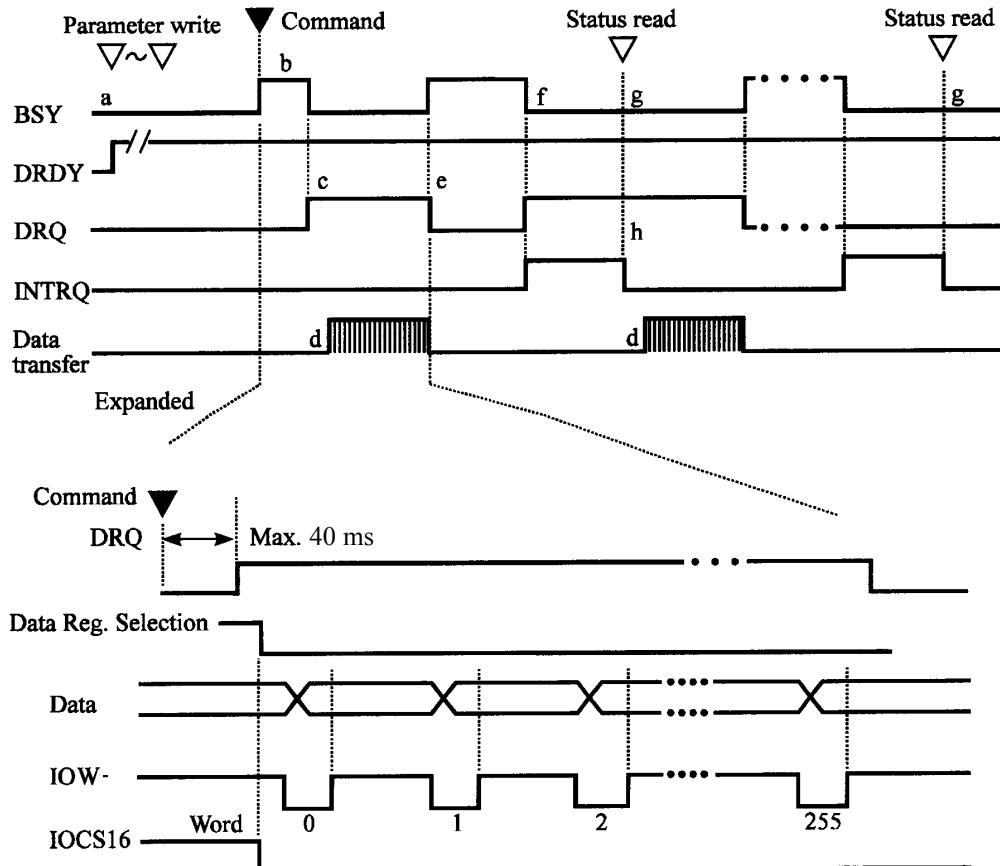

Figure 5.5 WRITE SECTOR(S) command protocol

IMPORTANT

For transfer of a sector of data, the host needs to read Status register (X'1F7') in order to clear INTRQ (interrupt) signal. The Status register should be read within a period from the DRQ setting by the device to starting of the sector data transfer. Note that the host does not need to read the Status register for the first and the last sector to be transferred. If the timing to read the Status register does not meet above condition, normal data transfer operation is not assured guaranteed.

When the host issues the command even if the drive requests the data transfer (DRQ bit is set), or when the host executes resetting, the device correct operation is not guaranteed.

5.4.3 Commands without data transfer

Execution of the following commands does not involve data transfer between the host and the device.

- RECABLIBRATE
- READY VERIFY SECTOR(S) (EXT)
- SEEK
- EXECUTE DEVICE DIAGNOSTIC
- INITIALIZE DEVICE PARAMETERS
- STANDBY IMMEDIATE
- IDLE (UNLOAD) IMMEDIATE
- STANDBY
- IDLE
- CHECK POWER MODE
- SLEEP
- SMART ENABLE/DISABLE AUTOSAVE
- SMART EXECUTE OFFLINE IMMEDIATE
- SMART ENABLE OPERATION
- SMART DISABLE OPERATION
- SMART RETURN STATUS
- DEVICE CONFIGURATION RESTORE
- DEVICE CONFIGURAION FREEZE LOCK
- SET MULTIPLE MODE
- FLUSH CACHE (EXT)
- SET FEATURES
- SECURITY ERASE PREPARE
- SECURITY FREEZE LOCK
- READ NATIVE MAX ADDRESS (EXT)
- SET MAX ADDRESS (EXT)

Figure 5.6 shows the protocol for the command execution without data transfer.

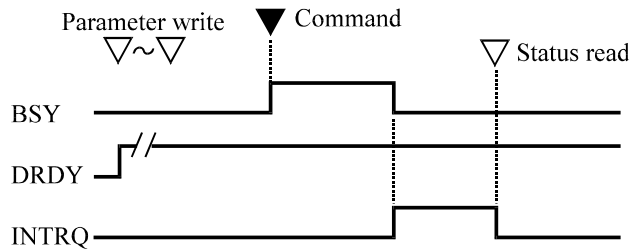

Figure 5.6 Protocol for the command execution without data transfer

5.4.4 Other commands

- READ MULTIPLE (EXT)
- WRITE MULTIPLE (EXT/FUA EXT)
- SLEEP

See the description of each command.

5.4.5 DMA data transfer commands

- READ DMA (EXT)
- WRITE DMA (EXT/FUA EXT)
- IDENTIFY DEVICE DMA

Starting the DMA transfer command is the same as the READ SECTOR(S) or WRITE SECTOR(S) command except the point that the host initializes the DMA channel preceding the command issuance.

Interrupt processing for DMA transfer does not issue interruptions in any intermediate sector when a multisector command is executed.

The following outlines the protocol:

The interrupt processing for the DMA transfer differs the following point.

- The interrupt processing for the DMA transfer differs the following point.
 - a) The host writes any parameters to the Features, Sector Count, Sector Number, Cylinder, and Device/Head register.
 - b) The host initializes the DMA channel
 - c) The host writes a command code in the Command register.
 - d) The device sets the BSY bit of the Status register.
 - e) The device asserts the DMARQ signal after completing the preparation of data transfer. The device asserts either the BSY bit or DRQ bit during DMA data transfer.

- f) When the command execution is completed, the device clears both BSY and DRQ bits and asserts the INTRQ signal. Then, the host reads the Status register.
- g) The host resets the DMA channel.

Figure 5.7 shows the correct DMA data transfer protocol.

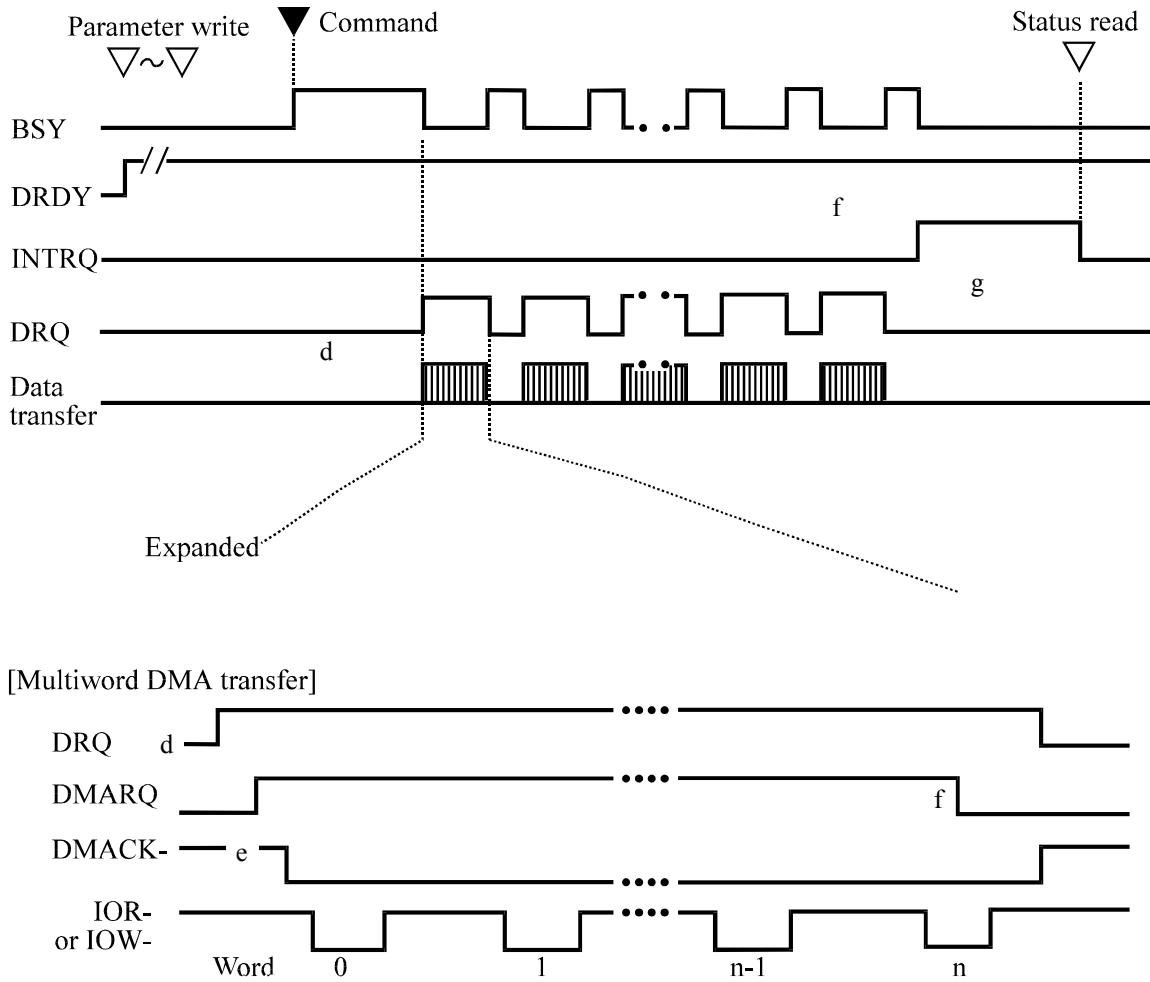

Figure 5.7 Normal DMA data transfer

5.5 Ultra DMA Feature Set

5.5.1 Overview

Ultra DMA is a data transfer protocol used with the READ DMA and WRITE DMA commands. When this protocol is enabled it shall be used instead of the Multiword DMA protocol when these commands are issued by the host. This protocol applies to the Ultra DMA data burst only. When this protocol is used there are no changes to other elements of the ATA protocol (e.g.: Command Block Register access).

Several signal lines are redefined to provide new functions during an Ultra DMA burst. These lines assume these definitions when 1) an Ultra DMA Mode is selected, and 2) a host issues a READ DMA or a WRITE DMA, command requiring data transfer, and 3) the host asserts DMACK-. These signal lines revert back to the definitions used for non-Ultra DMA transfers upon the negation of DMACK- by the host at the termination of an Ultra DMA burst. All of the control signals are unidirectional. DMARQ and DMACK- retain their standard definitions.

With the Ultra DMA protocol, the control signal (STROBE) that latches data from DD (15:0) is generated by the same agent (either host or device) that drives the data onto the bus. Ownership of DD (15:0) and this data strobe signal are given either to the device during an Ultra DMA data in burst or to the host for an Ultra DMA data out burst.

During an Ultra DMA burst a sender shall always drive data onto the bus, and after a sufficient time to allow for propagation delay, cable settling, and setup time, the sender shall generate a STROBE edge to latch the data. Both edges of STROBE are used for data transfers so that the frequency of STROBE is limited to the same frequency as the data.

Words in the IDENTIFY DEVICE data indicate support of the Ultra DMA feature and the Ultra DMA Modes the device is capable of supporting. The Set transfer mode subcommand in the SET FEATURES command shall be used by a host to select the Ultra DMA Mode at which the system operates. The Ultra DMA Mode selected by a host shall be less than or equal to the fastest mode of which the device is capable. Only the Ultra DMA Mode shall be selected at any given time. All timing requirements for a selected Ultra DMA Mode shall be satisfied. Devices supporting Ultra DMA Mode 2 shall also support Ultra DMA Modes 0 and 1. Devices supporting Ultra DMA Mode 1 shall also support Ultra DMA Mode 0.

An Ultra DMA capable device shall retain its previously selected Ultra DMA Mode after executing a Software reset sequence. An Ultra DMA capable device shall clear any previously selected Ultra DMA Mode and revert to its default non-Ultra DMA Modes after executing a Power on or hardware reset.

Both the host and device perform a CRC function during an Ultra DMA burst. At the end of an Ultra DMA burst the host sends the its CRC data to the device. The device compares its CRC data to the data sent from the host. If the two values do not match the device reports an error in the error register at the end of the command. If an error occurs during one or more Ultra DMA bursts for any one command, at the end of the command, the device shall report the first error that occurred.

5.5.2 Phases of operation

An Ultra DMA data transfer is accomplished through a series of Ultra DMA data in or data out bursts. Each Ultra DMA burst has three mandatory phases of operation: the initiation phase, the data transfer phase, and the Ultra DMA burst termination phase. In addition, an Ultra DMA burst may be paused during the data transfer phase (see 5.5.3 and 5.5.4 for the detailed protocol descriptions for each of these phases, 5.6 defines the specific timing requirements). In the following rules DMARDY- is used in cases that could apply to either DDMARDY- or HDMARDY-, and STROBE is used in cases that could apply to either DSTROBE or HSTROBE. The following are general Ultra DMA rules.

- a) An Ultra DMA burst is defined as the period from an assertion of DMACK- by the host to the subsequent negation of DMACK-.
- b) A recipient shall be prepared to receive at least two data words whenever it enters or resumes an Ultra DMA burst.

5.5.3 Ultra DMA data in commands

5.5.3.1 Initiating an Ultra DMA data in burst

The following steps shall occur in the order they are listed unless otherwise specifically allowed (see 5.6.3.1 and 5.6.3.2 for specific timing requirements):

- 1) The host shall keep DMACK- in the negated state before an Ultra DMA burst is initiated.
- 2) The device shall assert DMARQ to initiate an Ultra DMA burst. After assertion of DMARQ the device shall not negate DMARQ until after the first negation of DSTROBE.
- 3) Steps (3), (4) and (5) may occur in any order or at the same time. The host shall assert STOP.
- 4) The host shall negate HDMARDY-.
- 5) The host shall negate CS0-, CS1-, DA2, DA1, and DA0. The host shall keep CS0-, CS1-, DA2, DA1, and DA0 negated until after negating DMACK- at the end of the burst.
- 6) Steps (3), (4) and (5) shall have occurred at least t_{ACK} before the host asserts DMACK-. The host shall keep DMACK- asserted until the end of an Ultra DMA burst.
- 7) The host shall release DD (15:0) within t_{AZ} after asserting DMACK-.

- 8) The device may assert DSTROBE t_{ZIORDY} after the host has asserted DMACK-. Once the device has driven DSTROBE the device shall not release DSTROBE until after the host has negated DMACK- at the end of an Ultra DMA burst.
- 9) The host shall negate STOP and assert HDMARDY- within t_{ENV} after asserting DMACK-. After negating STOP and asserting HDMARDY-, the host shall not change the state of either signal until after receiving the first transition of DSTROBE from the device (i.e., after the first data word has been received).
- 10) The device shall drive DD (15:0) no sooner than t_{ZAD} after the host has asserted DMACK-, negated STOP, and asserted HDMARDY-.
- 11) The device shall drive the first word of the data transfer onto DD (15:0). This step may occur when the device first drives DD (15:0) in step (10).
- 12) To transfer the first word of data the device shall negate DSTROBE within t_{FS} after the host has negated STOP and asserted HDMARDY-. The device shall negate DSTROBE no sooner than t_{DVS} after driving the first word of data onto DD (15:0).

5.5.3.2 The data in transfer

The following steps shall occur in the order they are listed unless otherwise specifically allowed (see 5.6.3.3 and 5.6.3.2 for specific timing requirements):

- 1) The device shall drive a data word onto DD (15:0).
- 2) The device shall generate a DSTROBE edge to latch the new word no sooner than t_{DVS} after changing the state of DD (15:0). The device shall generate a DSTROBE edge no more frequently than t_{CYC} for the selected Ultra DMA Mode. The device shall not generate two rising or two falling DSTROBE edges more frequently than $2t_{CYC}$ for the selected Ultra DMA mode.
- 3) The device shall not change the state of DD (15:0) until at least t_{DVH} after generating a DSTROBE edge to latch the data.
- 4) The device shall repeat steps (1), (2) and (3) until the data transfer is complete or an Ultra DMA burst is paused, whichever occurs first.

5.5.3.3 Pausing an Ultra DMA data in burst

The following steps shall occur in the order they are listed unless otherwise specifically allowed (see 5.6.3.4 and 5.6.3.2 for specific timing requirements).

- a) Device pausing an Ultra DMA data in burst
 - 1) The device shall not pause an Ultra DMA burst until at least one data word of an Ultra DMA burst has been transferred.
 - 2) The device shall pause an Ultra DMA burst by not generating DSTROBE edges.

NOTE - The host shall not immediately assert STOP to initiate Ultra DMA burst termination when the device stops generating

STROBE edges. If the device does not negate DMARQ, in order to initiate ULTRA DMA burst termination, the host shall negate HDMARDY- and wait t_{RP} before asserting STOP.

- 3) The device shall resume an Ultra DMA burst by generating a DSTROBE edge.
- b) Host pausing an Ultra DMA data in burst
 - 1) The host shall not pause an Ultra DMA burst until at least one data word of an Ultra DMA burst has been transferred.
 - 2) The host shall pause an Ultra DMA burst by negating HDMARDY-.
 - 3) The device shall stop generating DSTROBE edges within t_{RFS} of the host negating HDMARDY-.
 - 4) If the host negates HDMARDY- within t_{SR} after the device has generated a DSTROBE edge, then the host shall be prepared to receive zero or one additional data words. If the host negates HDMARDY- greater than t_{SR} after the device has generated a DSTROBE edge, then the host shall be prepared to receive zero, one or two additional data words. The additional data words are a result of cable round trip delay and t_{RFS} timing for the device.
 - 5) The host shall resume an Ultra DMA burst by asserting HDMARDY-.

5.5.3.4 Terminating an Ultra DMA data in burst

- a) Device terminating an Ultra DMA data in burst

The following steps shall occur in the order they are listed unless otherwise specifically allowed (see 5.6.3.5 and 5.6.3.2 for specific timing requirements):

- 1) The device shall initiate termination of an Ultra DMA burst by not generating DSTROBE edges.
- 2) The device shall negate DMARQ no sooner than t_{SS} after generating the last DSTROBE edge. The device shall not assert DMARQ again until after the Ultra DMA burst is terminated.
- 3) The device shall release DD (15:0) no later than t_{AZ} after negating DMARQ.
- 4) The host shall assert STOP within t_{LI} after the device has negated DMARQ. The host shall not negate STOP again until after the Ultra DMA burst is terminated.
- 5) The host shall negate HDMARDY- within t_{LI} after the device has negated DMARQ. The host shall continue to negate HDMARDY- until the Ultra DMA burst is terminated. Steps (4) and (5) may occur at the same time.
- 6) The host shall drive DD (15:0) no sooner than t_{ZAH} after the device has negated DMARQ. For this step, the host may first drive DD (15:0) with the result of its CRC calculation (see 5.5.5):
- 7) If DSTROBE is negated, the device shall assert DSTROBE within t_{LI} after the host has asserted STOP. No data shall be transferred during this

assertion. The host shall ignore this transition on DSTROBE. DSTROBE shall remain asserted until the Ultra DMA burst is terminated.

- 8) If the host has not placed the result of its CRC calculation on DD (15:0) since first driving DD (15:0) during (6), the host shall place the result of its CRC calculation on DD (15:0) (see 5.5.5).
 - 9) The host shall negate DMACK- no sooner than t_{MLI} after the device has asserted DSTROBE and negated DMARQ and the host has asserted STOP and negated HDMARDY-, and no sooner than t_{DVS} after the host places the result of its CRC calculation on DD (15:0).
 - 10) The device shall latch the host's CRC data from DD (15:0) on the negating edge of DMACK-.
 - 11) The device shall compare the CRC data received from the host with the results of its own CRC calculation. If a miscompare error occurs during one or more Ultra DMA bursts for any one command, at the end of the command the device shall report the first error that occurred (see 5.5.5).
 - 12) The device shall release DSTROBE within t_{IORDYZ} after the host negates DMACK-.
 - 13) The host shall not negate STOP no assert HDMARDY- until at least t_{ACK} after negating DMACK-.
 - 14) The host shall not assert DIOR-, CS0-, CS1-, DA2, DA1, or DA0 until at least t_{ACK} after negating DMACK.
- b) Host terminating an Ultra DMA data in burst

The following steps shall occur in the order they are listed unless otherwise specifically allowed (see 5.6.3.6 and 5.6.3.2 for specific timing requirements):

- 1) The host shall not initiate Ultra DMA burst termination until at least one data word of an Ultra DMA burst has been transferred.
- 2) The host shall initiate Ultra DMA burst termination by negating HDMARDY-. The host shall continue to negate HDMARDY- until the Ultra DMA burst is terminated.
- 3) The device shall stop generating DSTROBE edges within t_{RFS} of the host negating HDMARDY-.

- 4) If the host negates HDMARDY- within t_{SR} after the device has generated a DSTROBE edge, then the host shall be prepared to receive zero or one additional data words. If the host negates HDMARDY- greater than t_{SR} after the device has generated a DSTROBE edge, then the host shall be prepared to receive zero, one or two additional data words. The additional data words are a result of cable round trip delay and t_{RFS} timing for the device.
- 5) The host shall assert STOP no sooner than t_{RP} after negating HDMARDY-. The host shall not negate STOP again until after the Ultra DMA burst is terminated.
- 6) The device shall negate DMARQ within t_{LI} after the host has asserted STOP. The device shall not assert DMARQ again until after the Ultra DMA burst is terminated.
- 7) If DSTROBE is negated, the device shall assert DSTROBE within t_{LI} after the host has asserted STOP. No data shall be transferred during this assertion. The host shall ignore this transition on DSTROBE. DSTROBE shall remain asserted until the Ultra DMA burst is terminated.
- 8) The device shall release DD (15:0) no later than t_{AZ} after negating DMARQ.
- 9) The host shall drive DD (15:0) no sooner than t_{ZAH} after the device has negated DMARQ. For this step, the host may first drive DD (15:0) with the result of its CRC calculation (see 5.5.5).
- 10) If the host has not placed the result of its CRC calculation on DD (15:0) since first driving DD (15:0) during (9), the host shall place the result of its CRC calculation on DD (15:0) (see 5.5.5).
- 11) The host shall negate DMACK- no sooner than t_{MLI} after the device has asserted DSTROBE and negated DMARQ and the host has asserted STOP and negated HDMARDY-, and no sooner than t_{DVS} after the host places the result of its CRC calculation on DD (15:0).
- 12) The device shall latch the host's CRC data from DD (15:0) on the negating edge of DMACK-.
- 13) The device shall compare the CRC data received from the host with the results of its own CRC calculation. If a miscompare error occurs during one or more Ultra DMA burst for any one command, at the end of the command, the device shall report the first error that occurred (see 5.5.5).
- 14) The device shall release DSTROBE within t_{IORDYZ} after the host negates DMACK-.
- 15) The host shall neither negate STOP nor assert HDMARDY- until at least t_{ACK} after the host has negated DMACK-.
- 16) The host shall not assert DIOR-, CS0-, CS1-, DA2, DA1, or DA0 until at least t_{ACK} after negating DMACK.

5.5.4 Ultra DMA data out commands

5.5.4.1 Initiating an Ultra DMA data out burst

The following steps shall occur in the order they are listed unless otherwise specifically allowed (see 5.6.3.7 and 5.6.3.2 for specific timing requirements):

- 1) The host shall keep DMACK- in the negated state before an Ultra DMA burst is initiated.
- 2) The device shall assert DMARQ to initiate an Ultra DMA burst.
- 3) Steps (3), (4), and (5) may occur in any order or at the same time. The host shall assert STOP.
- 4) The host shall assert HSTROBE.
- 5) The host shall negate CS0-, CS1-, DA2, DA1, and DA0. The host shall keep CS0-, CS1-, DA2, DA1, and DA0 negated until after negating DMACK- at the end of the burst.
- 6) Steps (3), (4), and (5) shall have occurred at least t_{ACK} before the host asserts DMACK-. The host shall keep DMACK- asserted until the end of an Ultra DMA burst.
- 7) The device may negate DDMARDY- t_{ZIORDY} after the host has asserted DMACK-. Once the device has negated DDMARDY-, the device shall not release DDMARDY- until after the host has negated DMACK- at the end of an Ultra DMA burst.
- 8) The host shall negate STOP within t_{ENV} after asserting DMACK-. The host shall not assert STOP until after the first negation of HSTROBE.
- 9) The device shall assert DDMARDY- within t_{LI} after the host has negated STOP. After asserting DMARQ and DDMARDY- the device shall not negate either signal until after the first negation of HSTROBE by the host.
- 10) The host shall drive the first word of the data transfer onto DD (15:0). This step may occur any time during Ultra DMA burst initiation.
- 11) To transfer the first word of data: the host shall negate HSTROBE no sooner than t_{LI} after the device has asserted DDMARDY-. The host shall negate HSTROBE no sooner than t_{DVS} after the driving the first word of data onto DD (15:0).

5.5.4.2 The data out transfer

The following steps shall occur in the order they are listed unless otherwise specifically allowed (see 5.6.3.8 and 5.6.3.2 for specific timing requirements):

- 1) The host shall drive a data word onto DD (15:0).
- 2) The host shall generate an HSTROBE edge to latch the new word no sooner than t_{DVS} after changing the state of DD (15:0). The host shall generate an HSTROBE edge no more frequently than t_{CYC} for the selected Ultra DMA Mode. The host shall not generate two rising or falling HSTROBE edges more frequently than $2 t_{CYC}$ for the selected Ultra DMA mode.
- 3) The host shall not change the state of DD (15:0) until at least t_{DVH} after generating an HSTROBE edge to latch the data.
- 4) The host shall repeat steps (1), (2) and (3) until the data transfer is complete or an Ultra DMA burst is paused, whichever occurs first.

5.5.4.3 Pausing an Ultra DMA data out burst

The following steps shall occur in the order they are listed unless otherwise specifically allowed (see 5.6.3.9 and 5.6.3.2 for specific timing requirements).

- a) Host pausing an Ultra DMA data out burst
 - 1) The host shall not pause an Ultra DMA burst until at least one data word of an Ultra DMA burst has been transferred.
 - 2) The host shall pause an Ultra DMA burst by not generating an HSTROBE edge.

Note: The device shall not immediately negate DMARQ to initiate Ultra DMA burst termination when the host stops generating HSTROBE edges. If the host does not assert STOP, in order to initiate Ultra DMA burst termination, the device shall negate DDMARDY- and wait t_{RP} before negating DMARQ.

- 3) The host shall resume an Ultra DMA burst by generating an HSTROBE edge.
- b) Device pausing an Ultra DMA data out burst
 - 1) The device shall not pause an Ultra DMA burst until at least one data word of an Ultra DMA burst has been transferred.
 - 2) The device shall pause an Ultra DMA burst by negating DDMARDY-.
 - 3) The host shall stop generating HSTROBE edges within t_{RFS} of the device negating DDMARDY-.
 - 4) If the device negates DDMARDY- within t_{SR} after the host has generated an HSTROBE edge, then the device shall be prepared to receive zero or one additional data words. If the device negates DDMARDY- greater than t_{SR} after the host has generated an HSTROBE edge, then the device shall be prepared to receive zero, one or two additional data words. The additional data words are a result of cable round trip delay and t_{RFS} timing for the host.
 - 5) The device shall resume an Ultra DMA burst by asserting DDMARDY-.

5.5.4.4 Terminating an Ultra DMA data out burst

a) Host terminating an Ultra DMA data out burst

The following stops shall occur in the order they are listed unless otherwise specifically allowed (see 5.6.3.10 and 5.6.3.2 for specific timing requirements):

- 1) The host shall initiate termination of an Ultra DMA burst by not generating HSTROBE edges.
- 2) The host shall assert STOP no sooner than t_{SS} after it last generated an HSTROBE edge. The host shall not negate STOP again until after the Ultra DMA burst is terminated.
- 3) The device shall negate DMARQ within t_{LI} after the host asserts STOP. The device shall not assert DMARQ again until after the Ultra DMA burst is terminated.
- 4) The device shall negate DDMARDY- with t_{LI} after the host has negated STOP. The device shall not assert DDMARDY- again until after the Ultra DMA burst termination is complete.
- 5) If HSTROBE is negated, the host shall assert HSTROBE with t_{LI} after the device has negated DMARQ. No data shall be transferred during this assertion. The device shall ignore this transition on HSTROBE. HSTROBE shall remain asserted until the Ultra DMA burst is terminated.
- 6) The host shall place the result of its CRC calculation on DD (15:0) (see 5.5.5)
- 7) The host shall negate DMACK- no sooner than t_{MLI} after the host has asserted HSTROBE and STOP and the device has negated DMARQ and DDMARDY-, and no sooner than t_{DVS} after placing the result of its CRC calculation on DD (15:0).
- 8) The device shall latch the host's CRC data from DD (15:0) on the negating edge of DMACK-.
- 9) The device shall compare the CRC data received from the host with the results of its own CRC calculation. If a miscompare error occurs during one or more Ultra DMA bursts for any one command, at the end of the command, the device shall report the first error that occurred (see 5.5.5).
- 10) The device shall release DDMARDY- within t_{ORDYZ} after the host has negated DMACK-.
- 11) The host shall neither negate STOP nor negate HSTROBE until at least t_{ACK} after negating DMACK-.
- 12) The host shall not assert DIOW-, CS0-, CS1-, DA2, DA1, or DA0 until at least t_{ACK} after negating DMACK.

b) Device terminating an Ultra DMA data out burst

The following steps shall occur in the order they are listed unless otherwise specifically allowed (see 5.6.3.11 and 5.6.3.2 for specific timing requirements):

- 1) The device shall not initiate Ultra DMA burst termination until at least one data word of an Ultra DMA burst has been transferred.
- 2) The device shall initiate Ultra DMA burst termination by negating DDMARDY-.
- 3) The host shall stop generating an HSTROBE edges within t_{RFS} of the device negating DDMARDY-.
- 4) If the device negates DDMARDY- within t_{SR} after the host has generated an HSTROBE edge, then the device shall be prepared to receive zero or one additional data words. If the device negates DDMARDY- greater than t_{SR} after the host has generated an HSTROBE edge, then the device shall be prepared to receive zero, one or two additional data words. The additional data words are a result of cable round trip delay and t_{RFS} timing for the host.
- 5) The device shall negate DMARQ no sooner than t_{RP} after negating DDMARDY-. The device shall not assert DMARQ again until after the Ultra DMA burst is terminated.
- 6) The host shall assert STOP with t_{LI} after the device has negated DMARQ. The host shall not negate STOP again until after the Ultra DMA burst is terminated.
- 7) If HSTROBE is negated, the host shall assert HSTROBE with t_{LI} after the device has negated DMARQ. No data shall be transferred during this assertion. The device shall ignore this transition of HSTROBE. HSTROBE shall remain asserted until the Ultra DMA burst is terminated.
- 8) The host shall place the result of its CRC calculation on DD (15:0) (see 5.5.5).
- 9) The host shall negate DMACK- no sooner than t_{MLI} after the host has asserted HSTROBE and STOP and the device has negated DMARQ and DDMARDY-, and no sooner than t_{DVS} after placing the result of its CRC calculation on DD (15:0).
- 10) The device shall latch the host's CRC data from DD (15:0) on the negating edge of DMACK-.
- 11) The device shall compare the CRC data received from the host with the results of its own CRC calculation. If a miscompare error occurs during one or more Ultra DMA bursts for any one command, at the end of the command, the device shall report the first error that occurred (see 5.5.5).
- 12) The device shall release DDMARDY- within t_{ORDYZ} after the host has negated DMACK-.

- 13) The host shall neither negate STOP nor HSTROBE until at least t_{ACK} after negating DMACK-.
- 14) The host shall not assert DIOW-, CS0-, CS1-, DA2, DA1, or DA0 until at least t_{ACK} after negating DMACK.

5.5.5 Ultra DMA CRC rules

The following is a list of rules for calculating CRC, determining if a CRC error has occurred during an Ultra DMA burst, and reporting any error that occurs at the end of a command.

- a) Both the host and the device shall have a 16-bit CRC calculation function.
- b) Both the host and the device shall calculate a CRC value for each Ultra DMA burst.
- c) The CRC function in the host and the device shall be initialized with a seed of 4ABAh at the beginning of an Ultra DMA burst before any data is transferred.
- d) For each STROBE transition used for data transfer, both the host and the device shall calculate a new CRC value by applying the CRC polynomial to the current value of their individual CRC functions and the word being transferred. CRC is not calculated for the return of STROBE to the asserted state after the Ultra DMA burst termination request has been acknowledged.
- e) At the end of any Ultra DMA burst the host shall send the results of its CRC calculation function to the device on DD (15:0) with the negation of DMACK-.
- f) The device shall then compare the CRC data from the host with the calculated value in its own CRC calculation function. If the two values do not match, the device shall save the error and report it at the end of the command. A subsequent Ultra DMA burst for the same command that does not have a CRC error shall not clear an error saved from a previous Ultra DMA burst in the same command. If a miscompare error occurs during one or more Ultra DMA bursts for any one command, at the end of the command, the device shall report the first error that occurred.
- g) For READ DMA or WRITE DMA commands: When a CRC error is detected, it shall be reported by setting both ICRC and ABRT (bit 7 and bit 2 in the Error register) to one. ICRC is defined as the "Interface CRC Error" bit. The host shall respond to this error by re-issuing the command.
- h) A host may send extra data words on the last Ultra DMA burst of a data out command. If a device determines that all data has been transferred for a command, the device shall terminate the burst. A device may have already received more data words than were required for the command. These extra words are used by both the host and the device to calculate the CRC, but, on an Ultra DMA data out burst, the extra words shall be discarded by the device.

- i) The CRC generator polynomial is : $G(X) = X^{16} + X^{12} + X^5 + 1$.

Note: Since no bit clock is available, the recommended approach for calculating CRC is to use a word clock derived from the bus strobe. The combinational logic shall then be equivalent to shifting sixteen bits serially through the generator polynomial where DD0 is shifted in first and DD15 is shifted in last.

5.5.6 Series termination required for Ultra DMA

Series termination resistors are required at both the host and the device for operation in any of the Ultra DMA Modes. The following table describes recommended values for series termination at the host and the device.

Table 5.28 Recommended series termination for Ultra DMA

Signal	Host Termination	Device Termination
DIOR-:HDMARDY-:HSTROBE	22 ohm	82 ohm
DIOW-:STOP	22 ohm	82 ohm
CS0-, CS1-	33 ohm	82 ohm
DA0, DA1, DA2	33 ohm	82 ohm
DMACK-	22 ohm	82 ohm
DD15 through DD0	33 ohm	33 ohm
DMARQ	82 ohm	22 ohm
INTRQ	82 ohm	22 ohm
IORDY:DDMARDY-:DSTROBE	82 ohm	22 ohm
RESET-	33 ohm	82 ohm

Note: Only those signals requiring termination are listed in this table. If a signal is not listed, series termination is not required for operation in an Ultra DMA Mode. For signals also requiring a pull-up or pull-down resistor at the host see Figure 5.8.

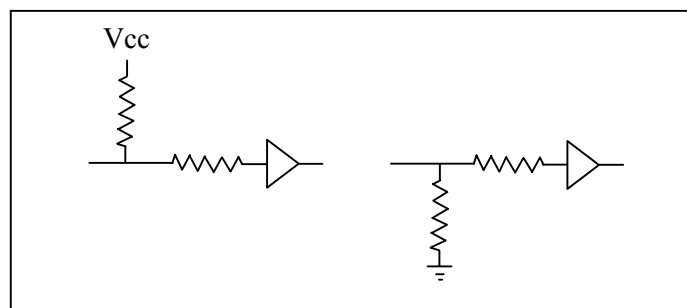
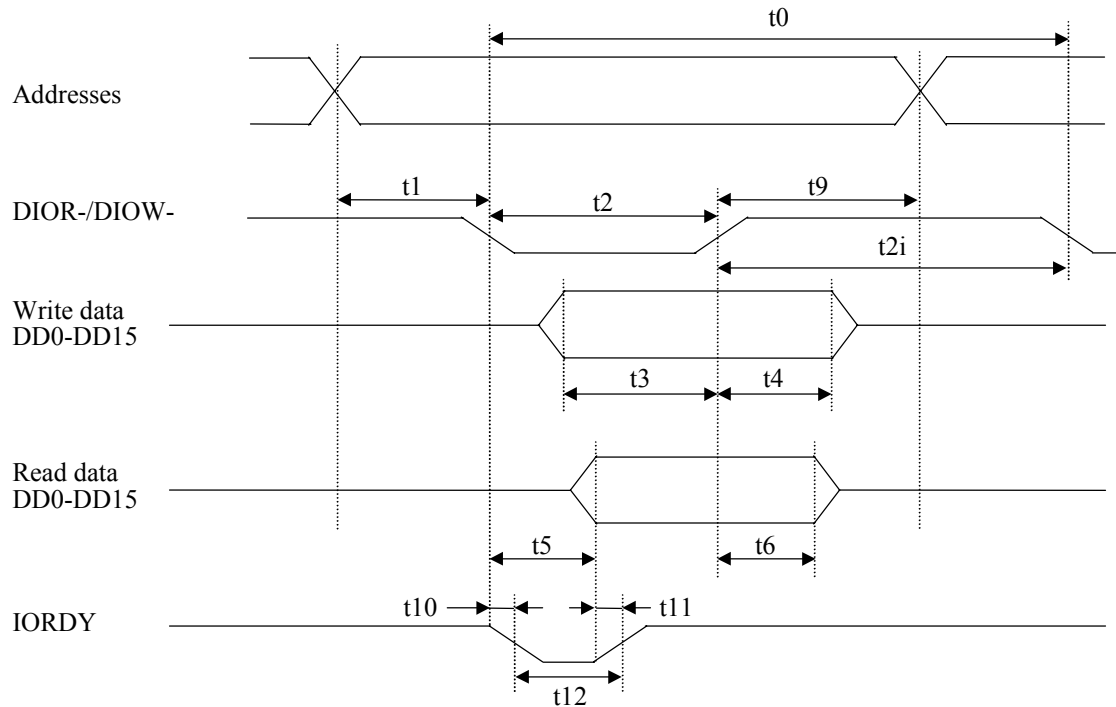

Figure 5.8 Ultra DMA termination with pull-up or pull-down

5.6 Timing

5.6.1 PIO data transfer

Figure 5.9 shows of the data transfer timing between the device and the host system.



Symbol	Timing parameter	Min.	Max.	Unit
t0	Cycle time	120	—	ns
t1	Data register selection setup time for DIOR-/DIOW-	25	—	ns
t2	Pulse width of DIOR-/DIOW-	70	—	ns
t2i	Recovery time of DIOR-/DIOW-	25	—	ns
t3	Data setup time for DIOW-	20	—	ns
t4	Data hold time for DIOW-	10	—	ns
t5	Time from DIOR- assertion to read data available	—	50	ns
t6	Data hold time for DIOR-	5	—	ns
t9	Data register selection hold time for DIOR-/DIOW-	10	—	ns
t10	Time from DIOR-/DIOW- assertion to IORDY "low" level	—	35	ns
t11	Time from validity of read data to IORDY "high" level	0	—	ns
t12	Pulse width of IORDY	—	1,250	ns

Figure 5.9 PIO data transfer timing

5.6.2 Multiword data transfer

Figure 5.10 shows the multiword DMA data transfer timing between the device and the host system.

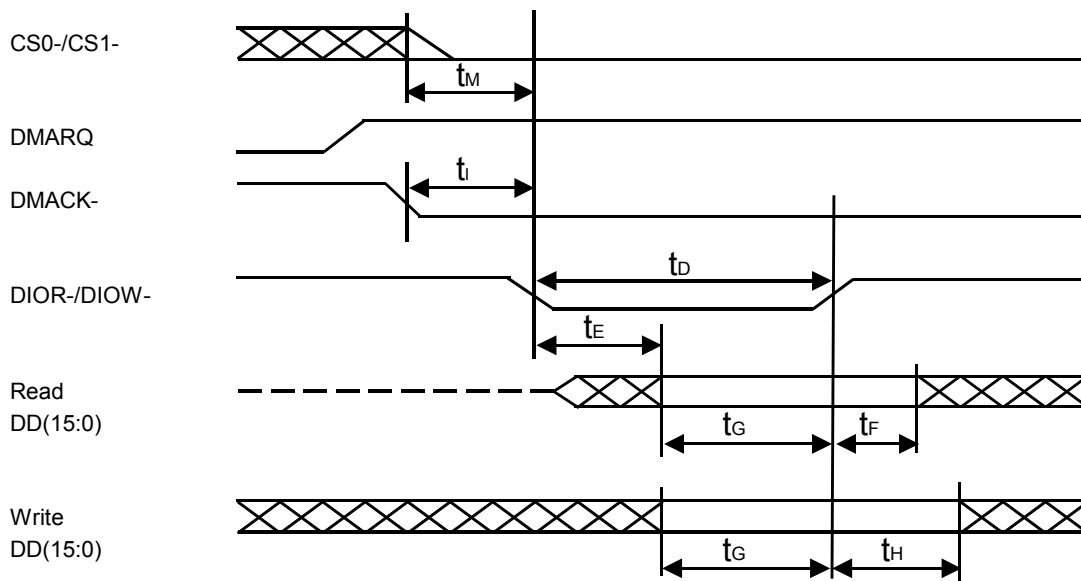

Symbol	Timing parameter	Min.	Max.	Unit
t_D	Pulse width of DIOR-/DIOW-	70	—	ns
t_E	Data Access time for DIOR-	—	50	ns
t_F	Data hold time for DIOR-	5	—	ns
t_G	Data setup time for DIOR-/DIOW-	20	—	ns
t_H	Data hold time for DIOW-	10	—	ns
t_i	DMACK setup time for DIOR-/DIOW-	0	—	ns
t	CS (1:0) Available time for DIOR-/DIOW-	25	—	ns

Figure 5.10 Multiword DMA data transfer timing (mode 2)

5.6.3 Ultra DMA data transfer

Figures 5.11 through 5.20 define the timings associated with all phases of Ultra DMA bursts.

Table 5.23 contains the values for the timings for each of the Ultra DMA Modes.

5.6.3.1 Initiating an Ultra DMA data in burst

5.6.3.2 contains the values for the timings for each of the Ultra DMA Modes.

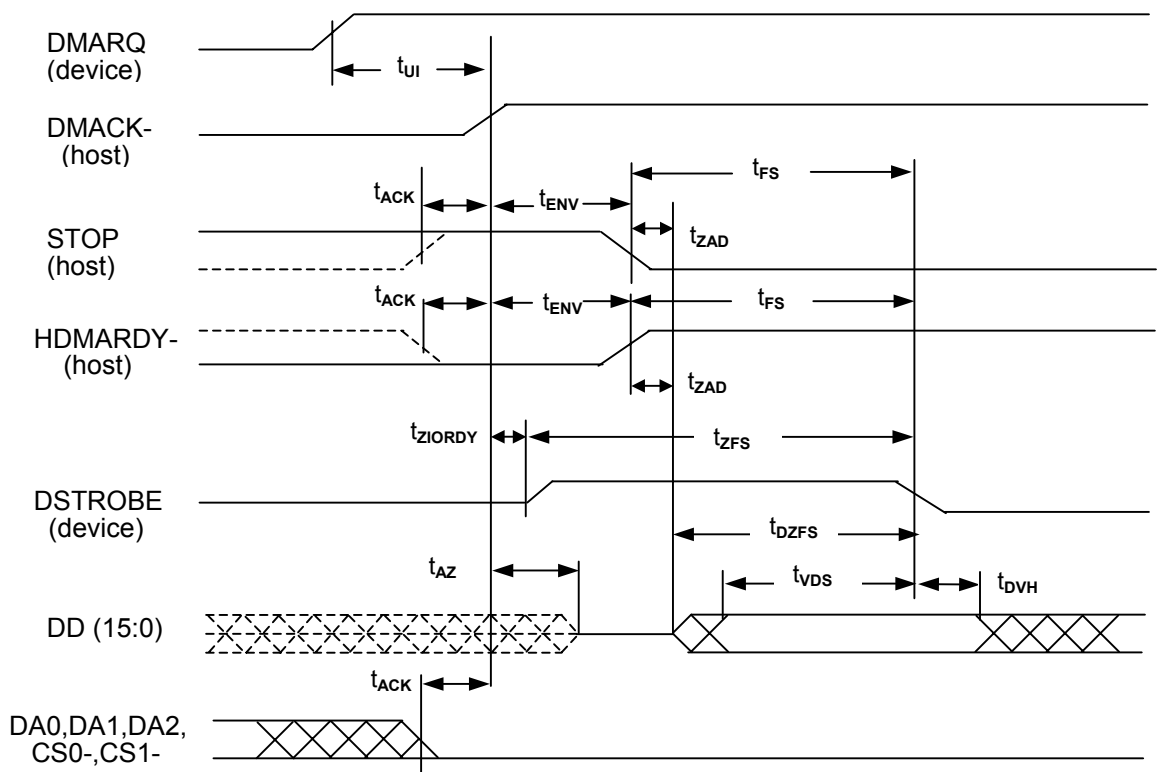

Note:

The definitions for the STOP, HDMARDY- and DSTROBE signal lines are not in effect until DMARQ and DMACK- are asserted.

Figure 5.11 Initiating an Ultra DMA data in burst

5.6.3.2 Ultra DMA data burst timing requirements

Table 5.29 Ultra DMA data burst timing requirements (1 of 2)

NAME	MODE 0 (in ns)		MODE 1 (in ns)		MODE 2 (in ns)		MODE 3 (in ns)		MODE 4 (in ns)		MODE 5 (in ns)		COMMENT
	MIN	MAX	MIN	MAX	MIN	MAX	MIN	MAX	MIN	MAX	MIN	MAX	
$t_{2CYCTYP}$	240		160		120		90		60		40		Typical sustained average two cycle time
t_{CYC}	112		73		54		39		25		16.8		Cycle time allowing for asymmetry and clock variations (from STROBE edge to STROBE edge)
t_{2CYC}	230		153		115		86		57		38		Two cycle time allowing for clock variations (from rising edge to next rising edge or from falling edge to next falling edge of STROBE)
t_{DS}	15		10		7		7		5		4		Data setup time at recipient (from data valid until STROBE edge) (*2), (*5)
t_{DH}	5		5		5		5		5		4.6		Data hold time at recipient (from STROBE edge until data may become invalid) (*2), (*5)
t_{DVS}	70		48		31		20		6.7		4.8		Data valid setup time at sender (from data valid until STROBE edge) (*3)
t_{DVH}	6.2		6.2		6.2		6.2		6.2		4.8		Data valid hold time at sender (from STROBE edge until data may become invalid) (*3)
t_{CS}	15		10		7		7		5		5		CRC word setup time at device (*2)
t_{CH}	5		5		5		5		5		5		CRC word hold time device (*2)
t_{CVS}	70		48		31		20		6.7		10		CRC word valid setup time at host (from CRC valid until DMACK-negation) (*3)
t_{CVH}	6.2		6.2		6.2		6.2		6.2		10		CRC word valid hold time at sender (from DMACK-negation until CRC may become invalid) (*3)
t_{ZFS}	0		0		0		0		0		35		Time from STROBE output released-to-driving until the first transition of critical timing
t_{DZFS}	70		48		31		20		6.7		25		Time from data output released-to-driving until the first transition of critical timing
t_{FS}		230		200		170		130		120		90	First STROBE time (for device to first negate DSTROBE from STOP during a data in burst)

Table 5.29 Ultra DMA data burst timing requirements (2 of 2)

NAME	MODE 0 (in ns)		MODE 1 (in ns)		MODE 2 (in ns)		MODE 3 (in ns)		MODE 4 (in ns)		MODE 5 (in ns)		COMMENT
	MIN	MAX	MIN	MAX	MIN	MAX	MIN	MAX	MIN	MAX	MIN	MAX	
t_{LI}	0	150	0	150	0	150	0	100	0	100	0	75	Limited interlock time (*1)
t_{MLI}	20		20		20		20		20		20		Interlock time with minimum (*1)
T_{UI}	0		0		0		0		0		0		Unlimited interlock time (*1)
t_{AZ}		10		10		10		10		10		10	Maximum time allowed for output drivers to release (from asserted or negated)
t_{ZAH}	20		20		20		20		20		20		Minimum delay time required for output
t_{ZAD}	0		0		0		0		0		0		Drivers to assert or negate (from released)
t_{ENV}	20	70	20	70	20	70	20	55	20	55	20	50	Envelope time (from DMACK- to STOP and HDMARDY- during data in burst initiation and from DMACK to STOP during data out burst initiation)
t_{RFS}		75		70		60		60		60		50	Ready-to-final-STROBE time (no STROBE edges shall be sent this long after negation of DMARDY-)
t_{RP}	160		125		100		100		100		85		Ready-to-pause time (that recipient shall wait to pause after negating DMARDY-)
t_{IORDYZ}		20		20		20		20		20		20	Maximum time before releasing IORDY
t_{ZIORDY}	0		0		0		0		0		0		Minimum time before driving IORDY (*4)
t_{ACK}	20		20		20		20		20		20		Setup and hold times for DMACK- (before assertion or negation)
t_{SS}	50		50		50		50		50		50		Time from STROBE edge to negation of DMARQ or assertion of STOP (when sender terminates a burst)
<p>*1: Except for some instances of t_{MLI} that apply to host signals only, the parameters t_{UI}, t_{MLI} and t_{LI} indicate sender-to-recipient or recipient-to-sender interlocks, i.e., one agent (either sender or recipient) is waiting for the other agent to respond with a signal before proceeding. t_{UI} is an unlimited interlock that has no maximum time value. t_{MLI} is a limited time-out that has a defined minimum. t_{LI} is a limited time-out that has a defined maximum.</p> <p>*2: 80-conductor cabling shall be required in order to meet setup (t_{DS}, t_{CS}) and hold (t_{DH}, t_{CH}) times in modes greater than 2.</p> <p>*3: Timing for t_{DVS}, t_{DVH}, t_{CVS} and t_{CVH} shall be met for lumped capacitive loads of 15 and 40 pF at the connector where all signals (Data and STROBE) have the same capacitive load value. Due to reflections on the cable, the measurement of these timings is not valid in a normally functioning system.</p> <p>*4: For all modes the parameter t_{ZIORDY} may be greater than t_{ENV} due to the fact that the host has a pull up on IORDY- giving it a known state when not actively driven.</p> <p>*5: The parameters t_{DS}, and t_{DH} for mode 5 is defined for a recipient at the end of the cable only in a configuration with one device at the end of the cable.</p> <p>Note: All timing measurement switching points (low to high and high to low) shall be taken at 1.5V.</p>													

Table 5.30 Ultra DMA sender and recipient timing requirements

NAME	MODE 0 (in ns)		MODE 1 (in ns)		MODE 2 (in ns)		MODE 3 (in ns)		MODE 4 (in ns)		MODE 5 (in ns)		COMMENT
	MIN	MAX	MIN	MAX	MIN	MAX	MIN	MAX	MIN	MAX	MIN	MAX	
t_{DSIC}	14.7		9.7		6.8		6.8		4.8		2.3		Recipient IC data setup time (from data valid until STROBE edge) (*1)
t_{DHIC}	4.8		4.8		4.8		4.8		4.8		2.8		Recipient IC data hold time (from STROBE edge until data may become invalid) (*1)
t_{DVSIC}	72.9		50.9		33.9		22.6		9.5		6		Sender IC data valid setup time (from data valid until STROBE edge) (*2)
t_{DVHIC}	9		9		9		9		9		6		Sender IC data valid hold time (from STROBE edge until data may become invalid) (*2)
<p>*1: The correct data value shall be captured by the recipient given input data with a slew rate of 0.4 V/ns rising and falling and the input STROBE with a slew rate of 0.4 V/ns rising and falling at t_{DSIC} and t_{DHIC} timing (as measured through 1.5V).</p> <p>*2: The parameters t_{DVSIC} and t_{DVHIC} shall be met for lumped capacitive loads of 15 and 40 pf at the IC where all signals have the same capacitive load value. Noise that may couple onto the output signals from external sources in a normally functioning system has not been included in these values.</p> <p>Note: All timing measurement switching points (low to high and high to low) shall be taken at 1.5V.</p>													

5.6.3.3 Sustained Ultra DMA data in burst

5.6.3.2 contains the values for the timings for each of the Ultra DMA Modes.

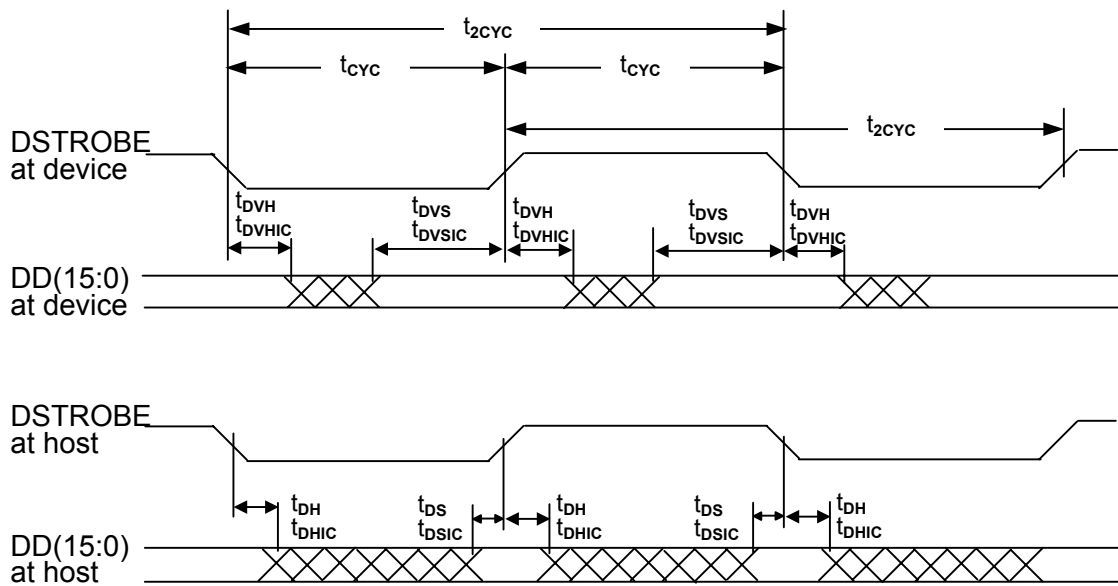

Note:

DD (15:0) and DSTROBE signals are shown at both the host and the device to emphasize that cable setting time as well as cable propagation delay shall not allow the data signals to be considered stable at the host until some time after they are driven by the device.

Figure 5.12 Sustained Ultra DMA data in burst

5.6.3.4 Host pausing an Ultra DMA data in burst

5.6.3.2 contains the values for the timings for each of the Ultra DMA Modes.

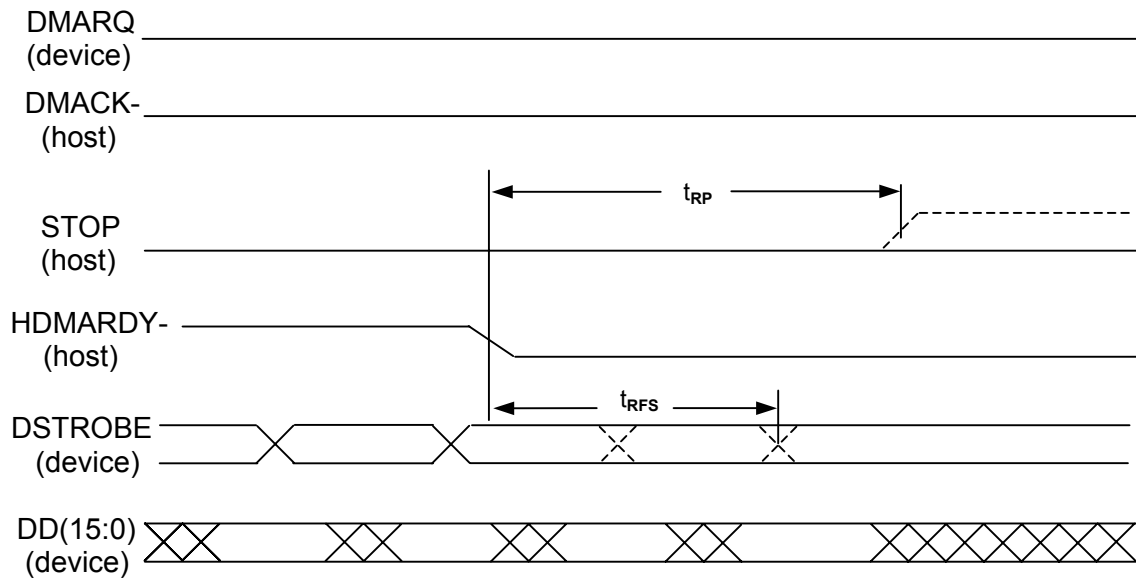

Notes:

- 1) The host may assert STOP to request termination of the Ultra DMA burst no sooner than t_{RP} after HDMARDY- is negated.
- 2) After negating HDMARDY-, the host may receive zero, one, two or three more data words from the device.

Figure 5.13 Host pausing an Ultra DMA data in burst

5.6.3.5 Device terminating an Ultra DMA data in burst

5.6.3.2 contains the values for the timings for each of the Ultra DMA Modes.

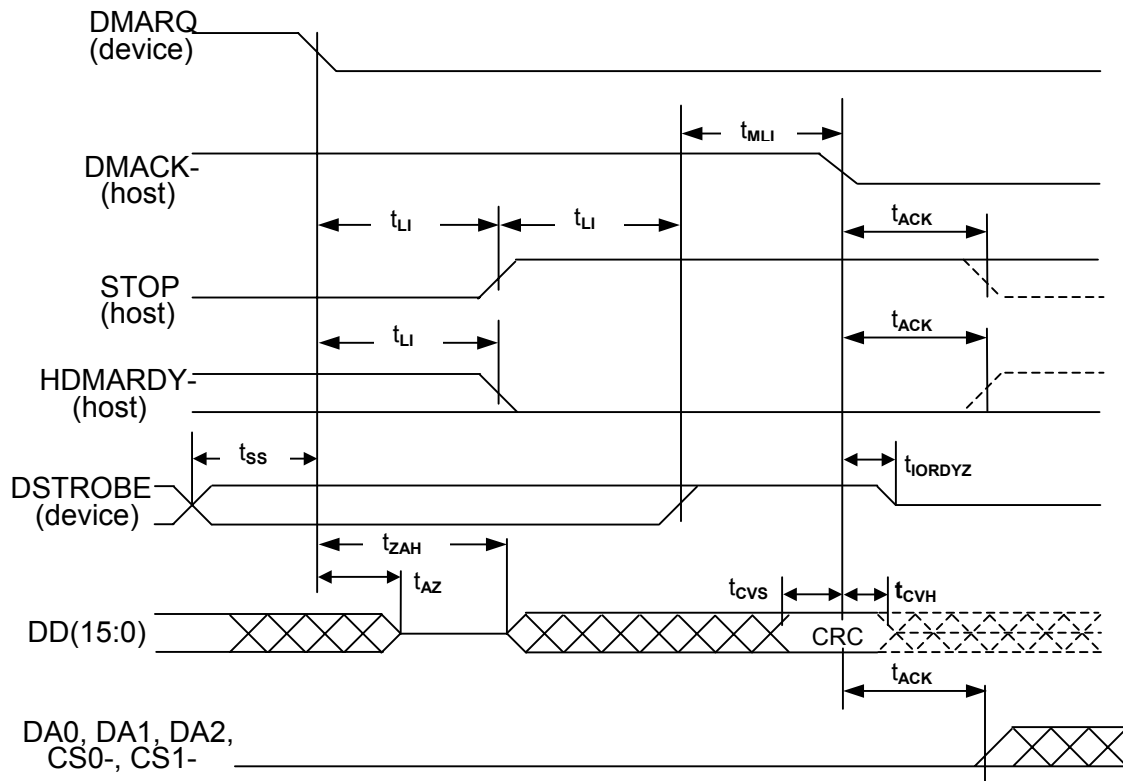

Note:

The definitions for the STOP, HDMARDY- and DSTROBE signal lines are no longer in effect after DMARQ and DMACK- are negated.

Figure 5.14 Device terminating an Ultra DMA data in burst

5.6.3.6 Host terminating an Ultra DMA data in burst

5.6.3.2 contains the values for the timings for each of the Ultra DMA Modes.

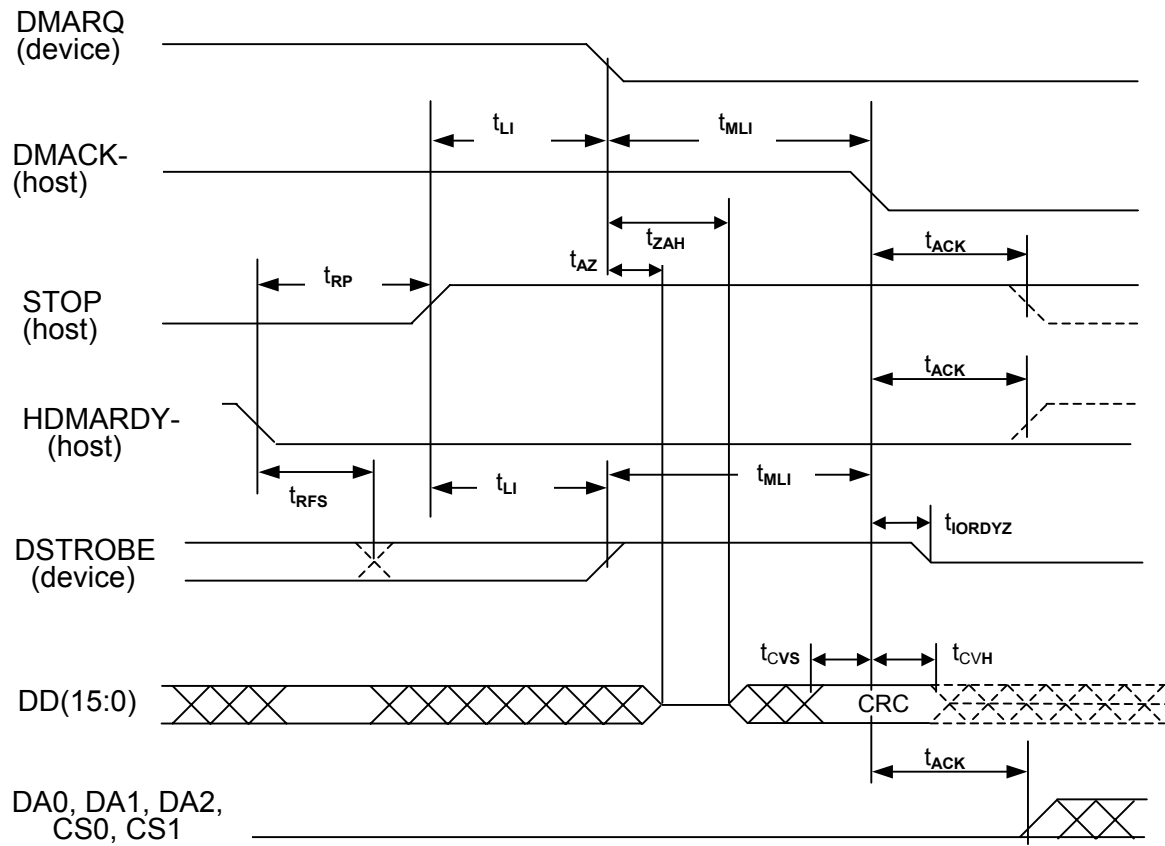

Note:

The definitions for the STOP, HDMARDY- and DSTROBE signal lines are no longer in effect after DMARQ and DMACK- are negated.

Figure 5.15 Host terminating an Ultra DMA data in burst

5.6.3.7 Initiating an Ultra DMA data out burst

5.6.3.2 contains the values for the timings for each of the Ultra DMA Modes.

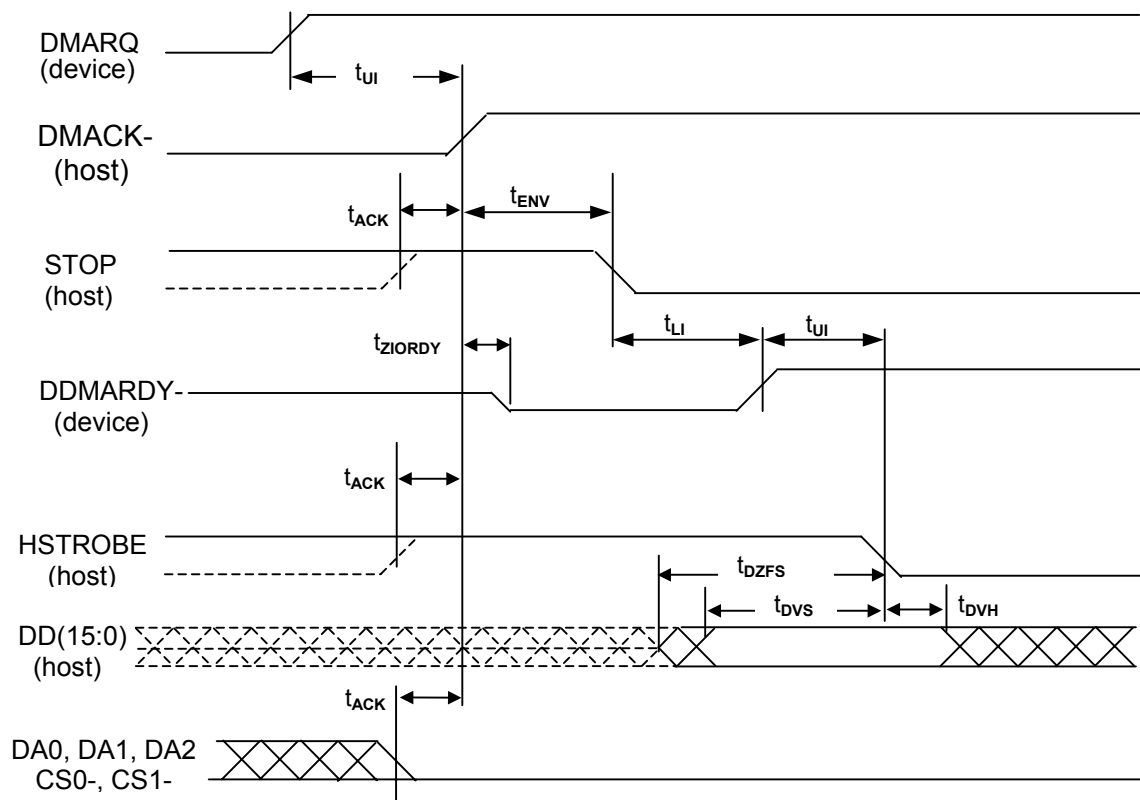

Note:

The definitions for the STOP, DDMARDY- and HSTROBE signal lines are not in effect until DMARQ and DMACK- are asserted.

Figure 5.16 Initiating an Ultra DMA data out burst

5.6.3.8 Sustained Ultra DMA data out burst

5.6.3.2 contains the values for the timings for each of the Ultra DMA Modes.

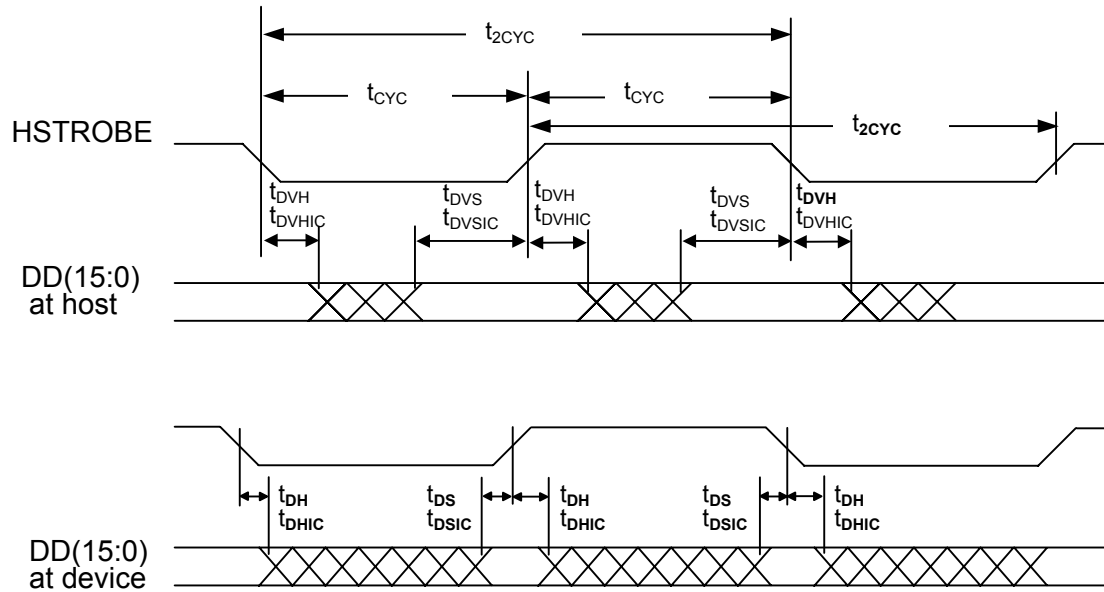

Note:

DD (15:0) and HSTROBE signals are shown at both the device and the host to emphasize that cable setting time as well as cable propagation delay shall not allow the data signals to be considered stable at the device until some time after they are driven by the host.

Figure 5.17 Sustained Ultra DMA data out burst

5.6.3.9 Device pausing an Ultra DMA data out burst

5.6.3.2 contains the values for the timings for each of the Ultra DMA Modes.

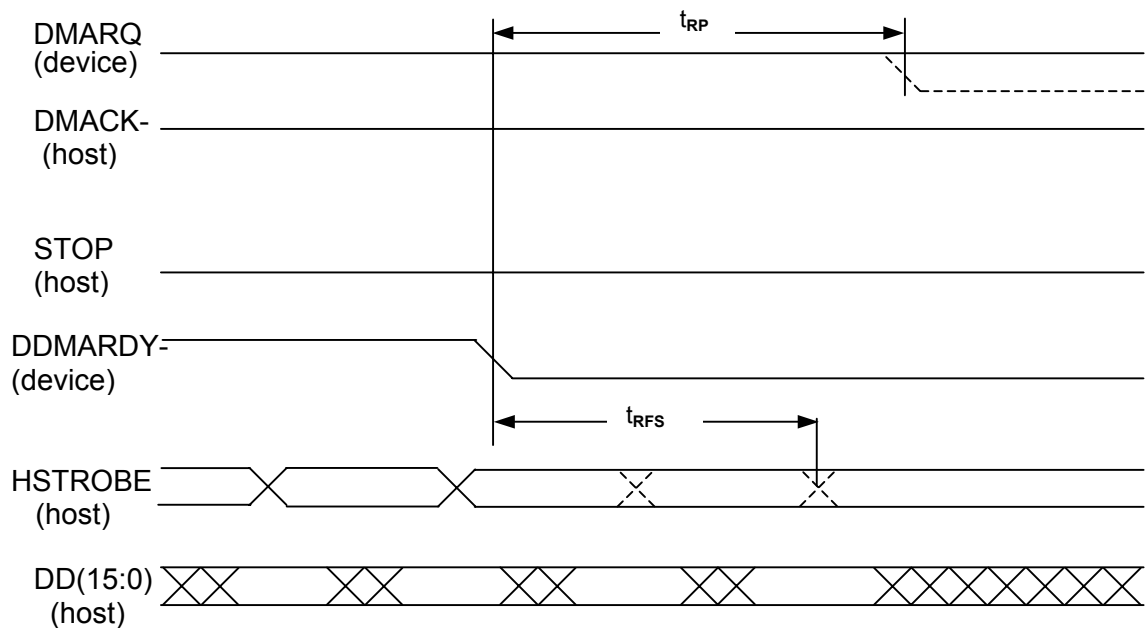

Notes:

- 1) The device may negate DMARQ to request termination of the Ultra DMA burst no sooner than t_{RP} after DDMARDY- is negated.
- 2) After negating DDMARDY-, the device may receive zero, one two or three more data words from the host.

Figure 5.18 Device pausing an Ultra DMA data out burst

5.6.3.10 Host terminating an Ultra DMA data out burst

5.6.3.2 contains the values for the timings for each of the Ultra DMA Modes.

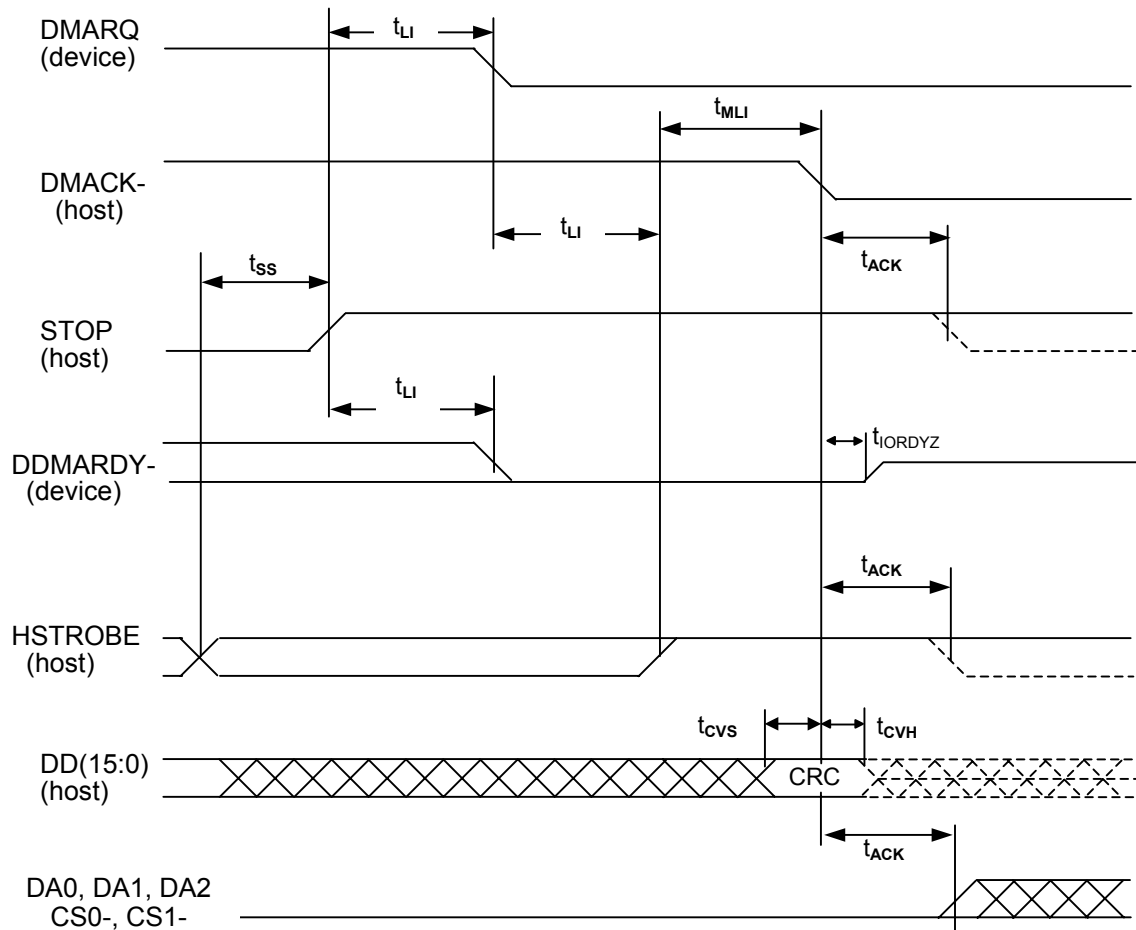

Note:

The definitions for the STOP, DDMARDY- and HSTROBE signal lines are no longer in effect after DMARQ and DMACK- are negated.

Figure 5.19 Host terminating an Ultra DMA data out burst

5.6.3.11 Device terminating an Ultra DMA data out burst

5.6.3.2 contains the values for the timings for each of the Ultra DMA Modes.

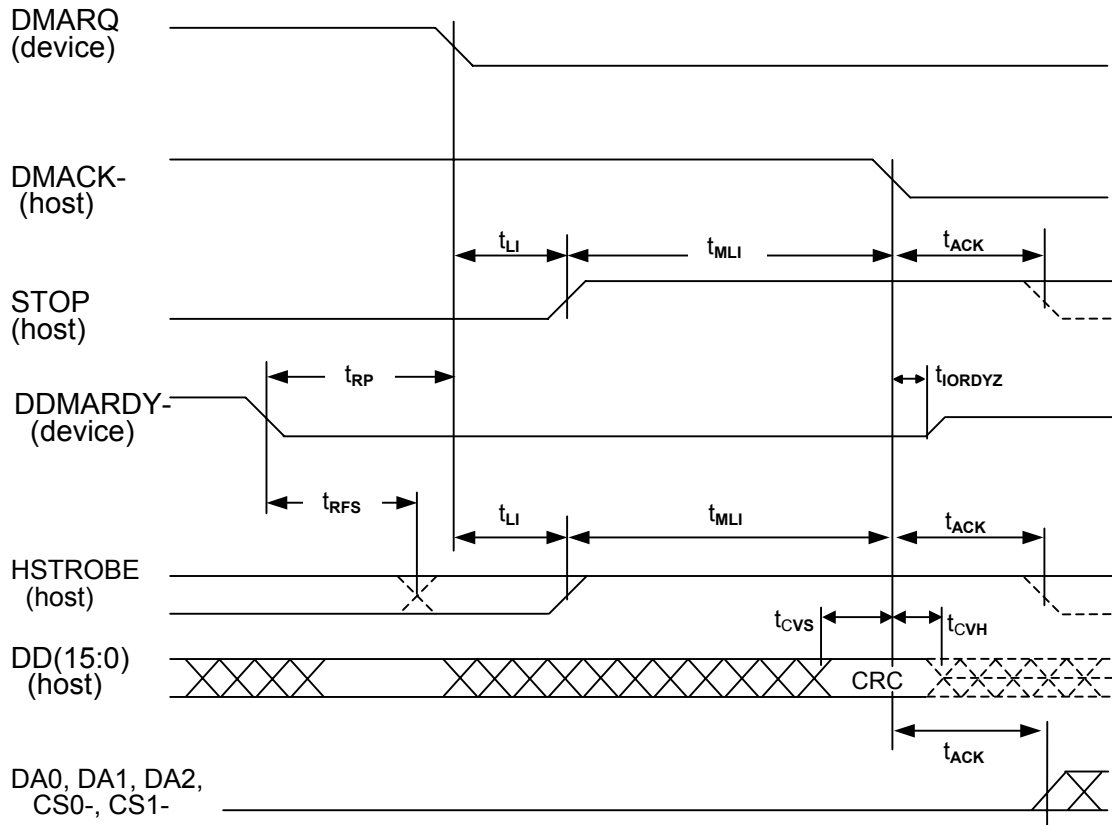

Note:

The definitions for the STOP, DDMARDY- and HSTROBE signal lines are no longer in effect after DMARQ and DMACK- are negated.

Figure 5.20 Device terminating an Ultra DMA data out burst

5.6.4 Power-on and reset

Figure 5.21 shows power-on and reset (hardware and software reset) timing.

(1) Only master device is present

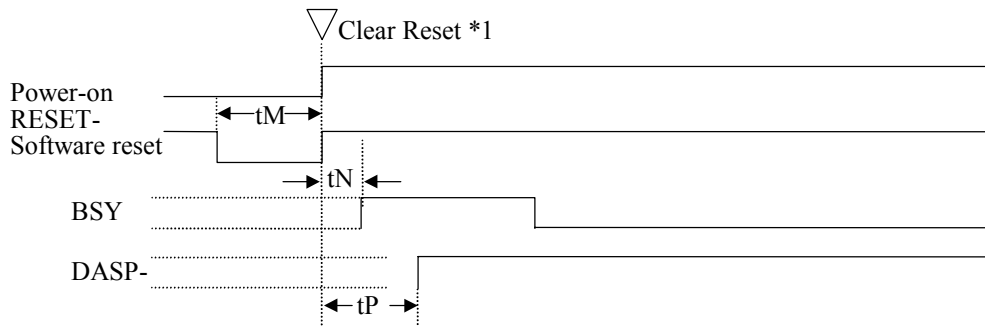

*1: Reset means including Power-on-Reset, Hardware Reset (RESET-), and Software Reset.

(2) Master and slave devices are present (2-drives configuration)

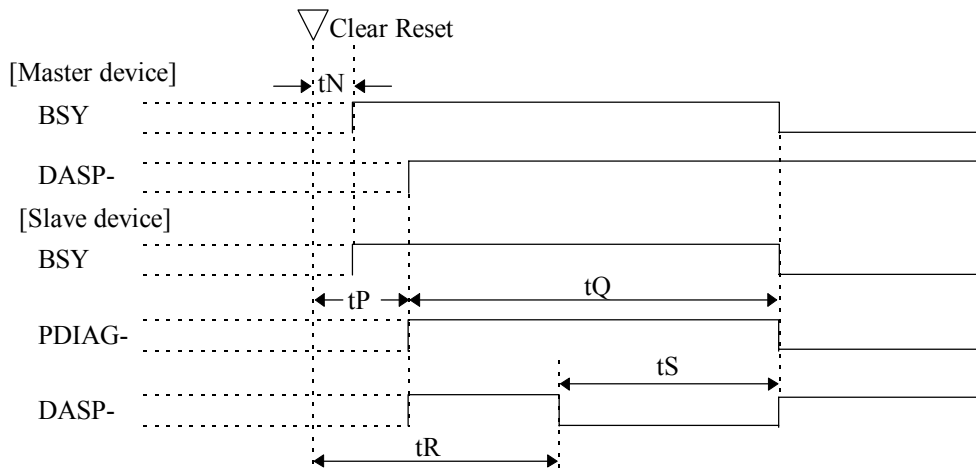

Symbol	Timing parameter	Min.	Max.	Unit
t_M	Pulse width of RESET-	25	—	μs
t_N	Time from RESET- negation to BSY set	—	400	ns
t_P	Time from RESET- negation to DASP- or DIAG- negation	—	1	ms
t_Q	Self-diagnostics execution time	—	30	s
t_R	Time from RESET- negation to DASP- assertion (slave device)	—	400	ms
t_S	Duration of DASP- assertion	—	31	s

Figure 5.21 Power-on reset timing

CHAPTER 6 Operations

- 6.1 Device Response to the Reset
- 6.2 Power Save
- 6.3 Defect Processing
- 6.4 Read-ahead Cache
- 6.5 Write Cache

6.1 Device Response to the Reset

This section describes how the PDIAG- and DASP- signals responds when the power of the IDD is turned on or the IDD receives a reset or diagnostic command.

6.1.1 Response to power-on

After the master device (device 0) releases its own power-on reset state, the master device shall check a DASP- signal for least 500 ms to confirm presence of a slave device (device 1). The master device recognizes presence of the slave device when it confirms assertion of the DASP- signal. Then, the master device checks a PDIAG- signal to see if the slave device has successfully completed the power-on diagnostics.

If the master device cannot confirm assertion of the DASP- signal within 500 ms, the master device recognizes that no slave device is connected.

After the slave device (device 1) releases its own power-on reset state, the slave device shall report its presence and the result of power-on diagnostics to the master device as described below:

DASP- signal: Asserted within 450 ms.

PDIAG- signal: Negated within 1 ms and asserted within 30 seconds.

The asserted PDIAG-signal is negated 30 seconds after it is asserted if the command is not received.

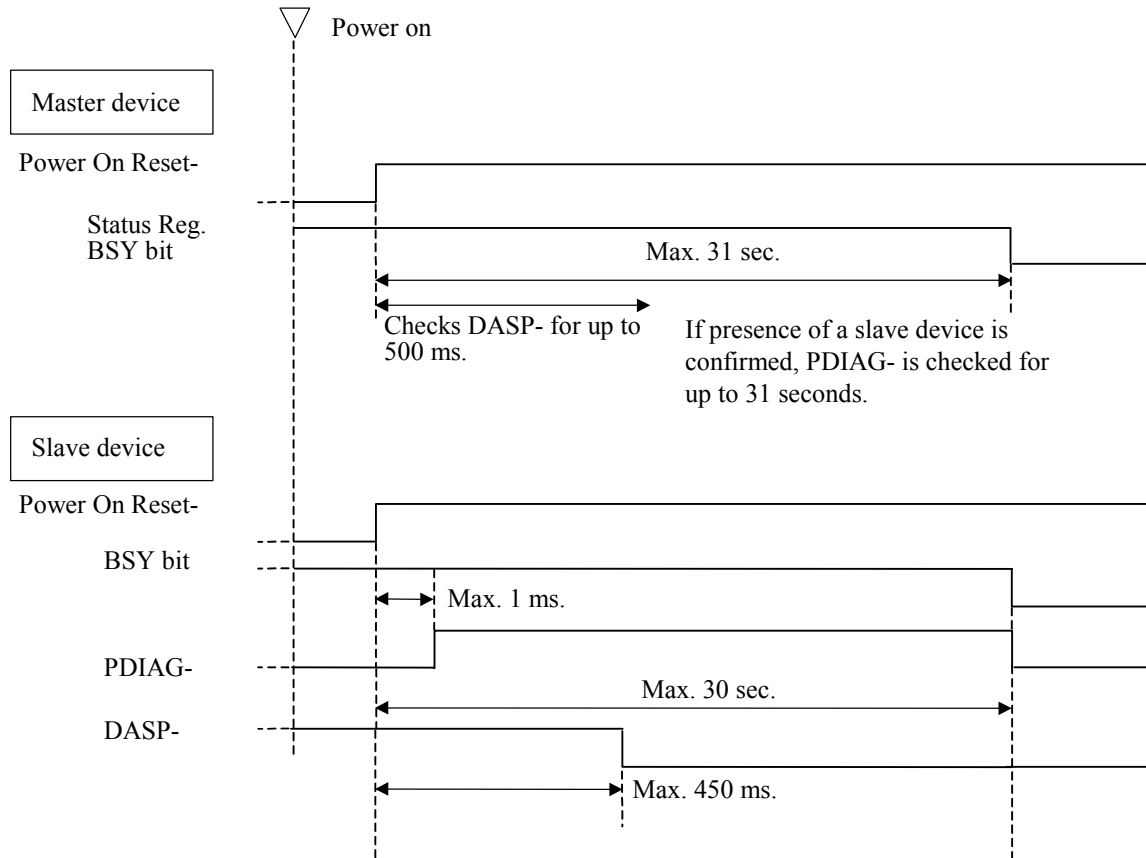

Figure 6.1 Response to power-on

Note: Figure 6.1 has an assumption that the device is kept on the power-off condition for more than 5 sec before the device power is turned on.

6.1.2 Response to hardware reset

Response to RESET- (hardware reset through the interface) is similar to the power-on reset.

Upon receipt of hardware reset, the master device checks a DASP- signal for up to 500 ms to confirm presence of a slave device. The master device recognizes the presence of the slave device when it confirms assertion of the DASP- signal. Then the master device checks a PDIAG- signal to see if the slave device has successfully completed the self-diagnostics.

If the master device cannot confirm assertion of the DASP- signal within 450 ms, the master device recognizes that no slave device is connected.

After the slave device receives the hardware reset, the slave device shall report its presence and the result of the self-diagnostics to the master device as described below:

DASP- signal: Asserted within 450 ms.

PDIAG- signal: Negated within 1 ms and asserted within 30 seconds.

The asserted PDIAG-signal is negated 30 seconds after it is asserted if the command is not received.

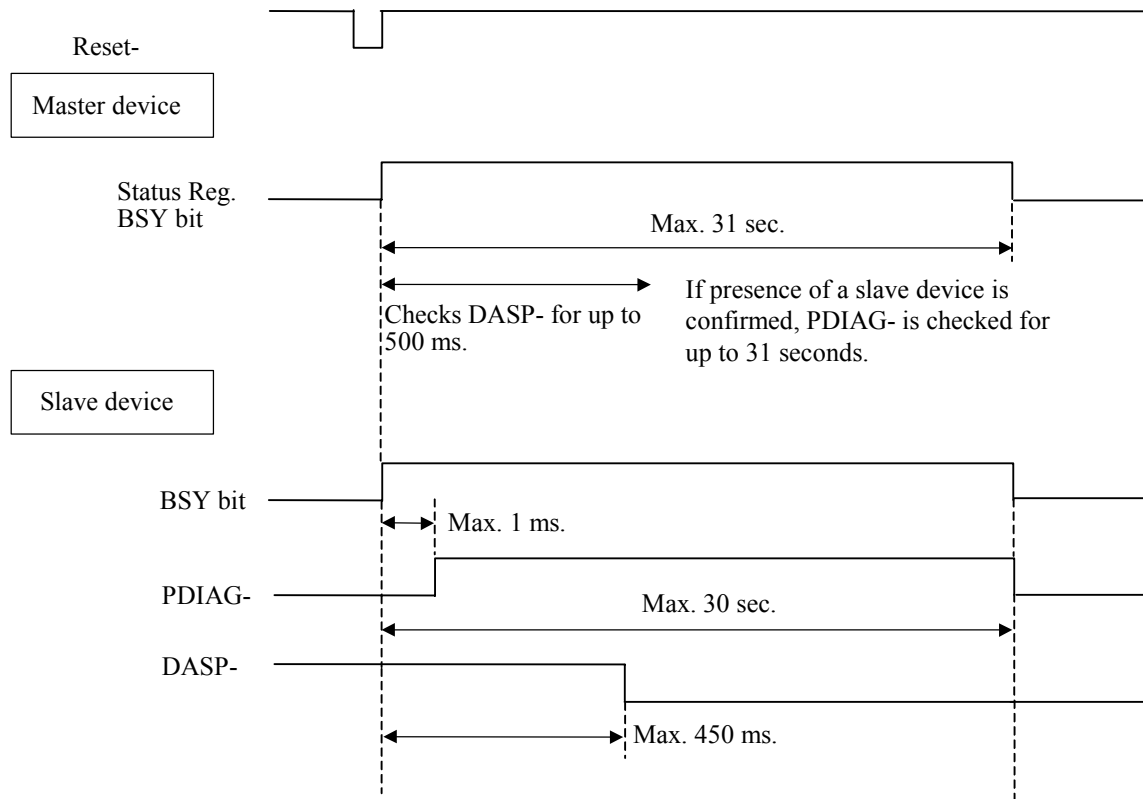

Figure 6.2 Response to hardware reset

Note: Master Device does not check the DASP signal assertion for 2ms upon receipt of hardware reset.

6.1.3 Response to software reset

The master device does not check the DASP- signal for a software reset. If a slave device is present, the master device checks the PDIAG- signal for up to 15 seconds to see if the slave device has completed the self-diagnosis successfully.

After the slave device receives the software reset, the slave device shall report its presence and the result of the self-diagnostics to the master device as described below:

PDIAG- signal: negated within 1 ms and asserted within 30 seconds

The asserted PDIAG-signal is negated 30 seconds after it is asserted if the command is not received.

When the IDD is set to a slave device, the IDD asserts the DASP- signal when negating the PDIAG- signal.

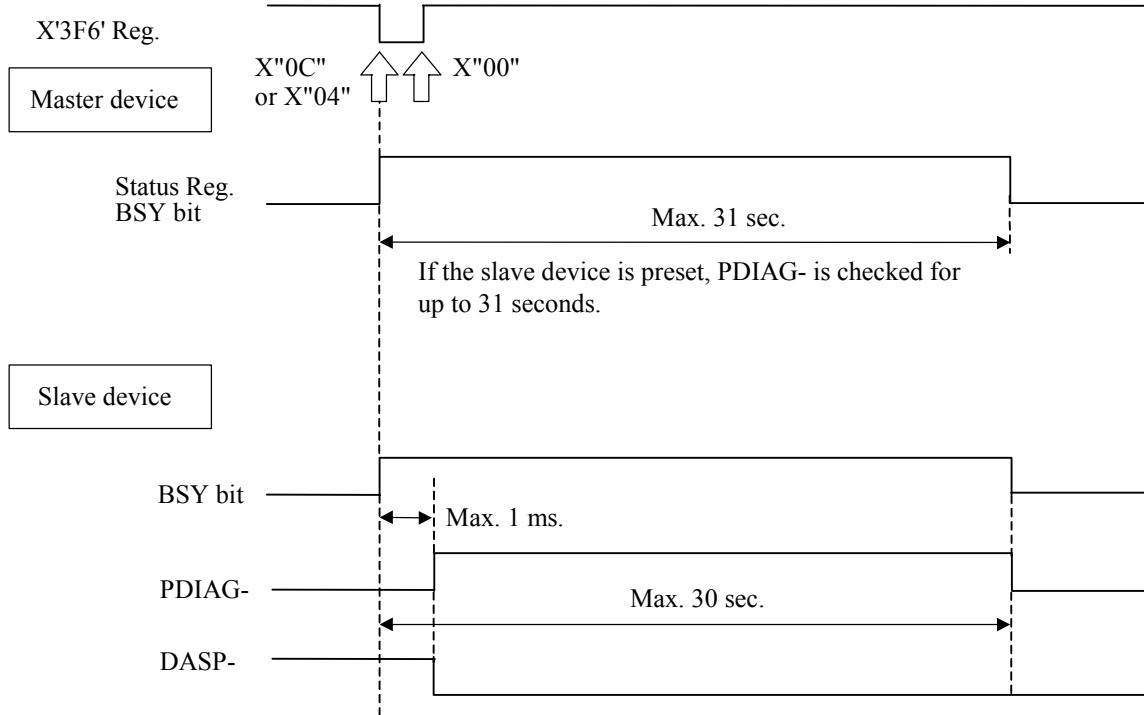

Figure 6.3 Response to software reset

6.1.4 Response to diagnostic command

When the master device receives an EXECUTE DEVICE DIAGNOSTIC command and the slave device is present, the master device checks the PDIAG- signal for up to 6 seconds to see if the slave device has completed the self-diagnosis successfully.

The master device does not check the DASP- signal.

After the slave device receives the EXECUTE DEVICE DIAGNOSTIC command, it shall report the result of the self-diagnostics to the master device as described below:

PDIAG- signal: negated within 1 ms and asserted within 5 seconds

The asserted PDIAG-signal is negated 5 seconds after it is asserted if the command is not received. If the command is received, the PDIAG-signal is negated according to timing at which the command is received.

When the IDD is set to a slave device, the IDD asserts the DASP- signal when negating the PDIAG- signal.

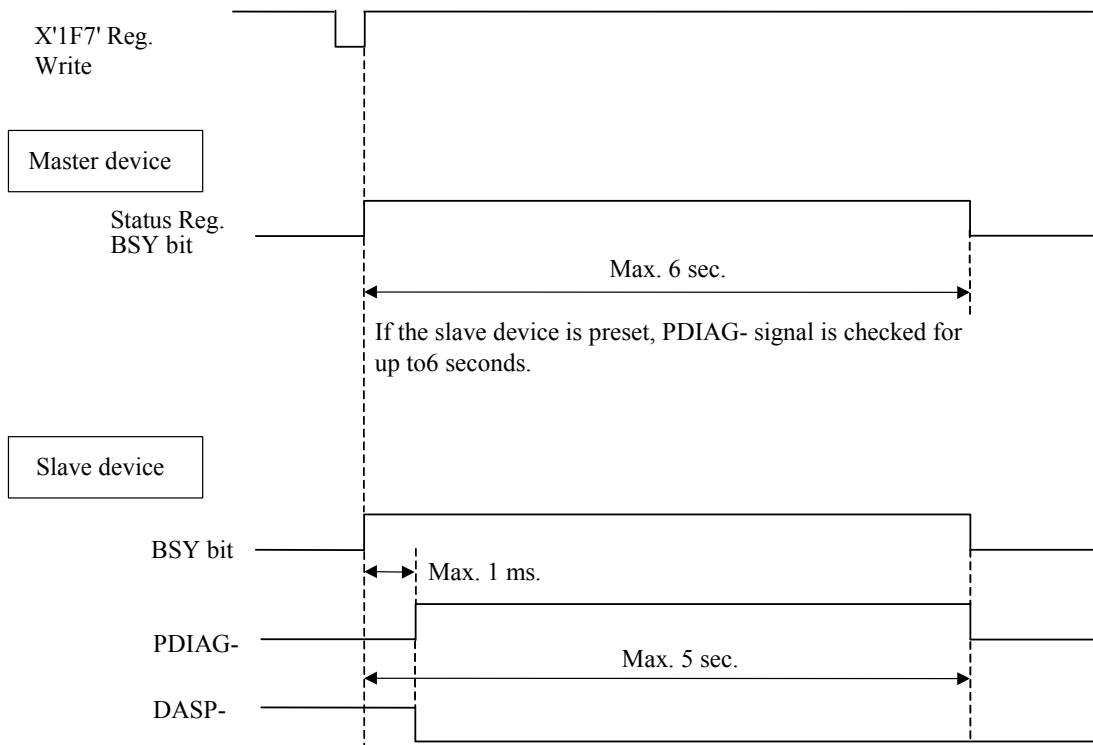

Figure 6.4 Response to diagnostic command

6.2 Power Save

The host can change the power consumption state of the device by issuing a power command to the device.

6.2.1 Power save mode

There are five types of power consumption state of the device including active mode where all circuits are active.

- Active mode
- Active idle mode
- Low power idle mode
- Standby mode
- Sleep mode

The device enters the active idle mode by itself. The device also enters the idle mode in the same way after power-on sequence is completed. The subsequent mode transition changes depending on the APM setting.

(1) Active mode

In this mode, all the electric circuit in the device are active or the device is under seek, read or write operation.

A device enters the active mode under the following conditions:

- The media access system is received.

(2) Active idle mode

In this mode, circuits on the device are set to power save mode.

The device enters the Active idle mode under the following conditions:

- After completion of the command execution other than SLEEP and STANDBY commands.

(3) Low power idle mode

Sets circuits on the device to the power save mode. The heads are disabled in the safe state.

The device enters the low power mode under the following conditions:

- After certain amount of time has elapsed in the active idle state (APM Mode 0, Mode 1 and Mode 2)
- Upon completion of the power-on sequence
- Upon receipt of a hard reset

- Upon receipt of Idle/Idle Intermediate

(4) Standby mode

In this mode, the spindle motor has stopped from the low power idle state.

The device can receive commands through the interface. However if a command with disk access is issued, response time to the command under the standby mode takes longer than the active, active idle, or low power idle mode because the access to the disk medium cannot be made immediately.

The drive enters the standby mode under the following conditions:

- A STANDBY or STANDBY IMMEDIATE command is issued.
- A certain amount of time has elapsed in the low power idle state. (APM Mode 2)
- The time specified by the STANDBY or IDLE command has elapsed after completion of the command.
- A reset is issued in the sleep mode.

When one of following commands is issued, the command is executed normally and the device is still stayed in the standby mode.

- Reset (hardware or software)
- STANDBY command
- STANDBY IMMEDIATE command
- INITIALIZE DEVICE PARAMETERS command
- CHECK POWER MODE command

(5) Sleep mode

The power consumption of the drive is minimal in this mode. The drive enters only the standby mode from the sleep mode. The only method to return from the standby mode is to execute a software or hardware reset.

The drive enters the sleep mode under the following condition:

- A SLEEP command is issued.

In this mode, the device does not accept the command. (It is ignored.)

6.2.2 Power commands

The following commands are available as power commands.

- IDLE
- IDLE IMMEDIATE
- STANDBY
- STANDBY IMMEDIATE
- SLEEP
- CHECK POWER MODE
- SET FEATURES (APM setting)

6.3 Defect Processing

This device performs alternating processing where the defective sector is alternated with the spare area depending on media defect location information. The media defect location information is registered in the system space specified for the user area according to the format at shipment of the media from the plant.

6.3.1 Spare area

The following type of area is prepared as the spare area in user areas:

- 1) Spare cylinder for alternate assignment: This cylinder is used during automatic alternating processing for defective sector. More than 2000 sectors/drive.

6.3.2 Alternating processing for defective sectors

The following two types of technology are used for alternating processing:

(1) Sector slip processing

In this method, defective sectors are not used (thereby avoiding the effects of defects), and each defective sector is assigned to the next contiguous sector that is normal.

Depending on the format defined at shipment from the plant, this processing is performed for defective sectors.

Figure 6.5 shows an example where sector (physical) 5 with cylinder 0 and head 0 is defective.

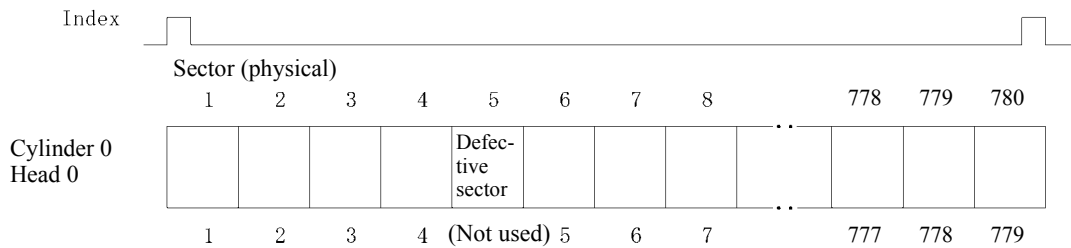

Note: When an access request for sector 5 is issued, physical sector 6 must be accessed instead of physical sector 5.

Figure 6.5 Sector slip processing

(2) Track slip processing

In this method, defective tracks not used (there by avoiding the effects of defects), and each defective track is assigned to the next contiguous track that is normal.

Depending on the format defined at shipment from the plant, this processing is performed for defective tracks.

(3) Automatic alternating processing

This technology assigns a defective sector to a spare sector of a spare cylinder for alternate assignment.

This device performs automatic alternating processing in the event of any of the following errors.

- Automatic alternating processing is attempted for read error recovery by reaching the specified retry cycle while a read error retry is in progress.

Before attempting automatic alternating processing, writing and reading of already corrected data is repeated for the sector in which an error occurred. If a read error does not occur during this reading operation, automatic alternating processing is not performed.

- If error recovery is not successful even if a write fault error retry is executed, automatic alternating processing is performed.

Figure 6.6 shows an example where automatic alternating processing is applied to sector (physical) 5 with cylinder 0 and head 0.

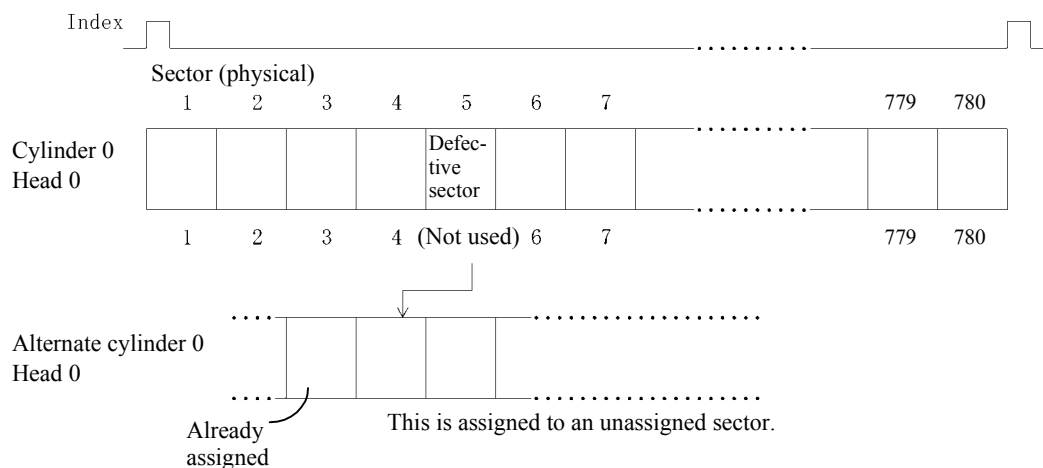

Notes:

1. The alternate cylinder is assigned to an inner cylinder in each zone.
2. When an access request for sector 5 is issued, the sector assigned for alternating processing of the alternate cylinder must be accessed instead of physical sector 5.

If an access request for sectors after sector 5 is issued, seek is executed to cylinder 0, head 0 in order to continue processing.

Figure 6.6 Automatic alternating processing

6.4 Read-ahead Cache

Read-ahead Cache is the function for automatically reading data blocks upon completion of the read command in order to read data from disk media and save data block on a data buffer.

If a subsequent command requests reading of the read-ahead data, data on the data buffer can be transferred without accessing the disk media. As the result, faster data access becomes possible for the host.

6.4.1 DATA buffer structure

This device contains a data buffer. This buffer is divided into two areas: one area is used for MPU work, and the other is used as a read cache for another command. (See Figure 6.7)

8MB buffer (8,388,608 bytes)

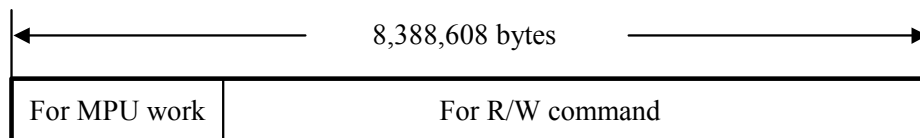

Figure 6.7 Data buffer structure

The read-ahead operation is done by the following commands.

- READ SECTOR(S) (EXT)
- READ MULTIPLE (EXT)
- READ DMA (EXT)
- READ SECTOR(S) EXT
- READ DMA EXT
- READ MULTIPLE EXT

6.4.2 Caching operation

The caching operation is performed only when the commands listed below are received. If any of the following data are stored on the data buffer, the data is sent to the host system.

- All of the sector data that this command processes.
- A part of the sector data including the start sector, that this command processes.

If part of the data to be processed is stored on the data buffer, the remaining data is read from disk media and sent to the host system.

(1) Commands that are targets of caching

The commands that are targets of caching are as follows:

- READ SECTOR(s)
- READ MULTIPLE
- READ DMA
- READ SECTOR(s) EXT
- READ DMA EXT
- READ MULTIPLE EXT

However, if the caching function is prohibited by the SET FEATURES command, the caching operation is not performed.

(2) Data that is a target of caching

The data that is a target of caching are as follows:

- 1) Read-ahead data that is read from disk media and saved to the data buffer upon completion of execution of a command that is a target of caching.
- 2) Pre-read data that is read from disk media and saved to the data buffer before execution of a command that is a target of caching.
- 3) Data required by a command that is a target of caching and has been sent to the host system one. If the sector data requested by the host has not been completely stored in the read cache portion of the buffer, this data does not become a target of caching. Also, if sequential hits occur continuously, the caching-target data required by the host becomes invalid because that data is overwritten by new data.

(3) Invalidating caching-target data

Data that is a target of caching on the data buffer is invalidated under the following conditions:

1)-1 Any command other than the following commands is issued. (All caching-target data is invalidated.)

RECALIBRATE

IDLE IMMEDIATE

DOWNLOAD MICROCODE

DEVICE CONFIGURATION

READ BUFFER

WRITE BUFFER

SET FEATURES

SECURITY ERASE UNIT

READ LOG EXT

WRITE LOG EXT

UNSUPPORT COMMAND (INVALID COMMAND)

1)-2 Commands that partially invalidate caching data

(When data in the buffer or on media is overwritten, the overwritten data is invalidated.)

READ SECTOR (s) / READ MULTIPLE / READ DMA

READ SECTOR (s) EXT / READ DMA EXT / READ MULTIPLE EXT

WRITE SECTOR(s) / WRITE MULTIPLE / WRITE DMA

WRITE SECTOR (s) EXT / WRITE DMA EXT / WRITE MULTIPLE EXT

WRITE DMA FUA EXT / WRITE MULTIPLE FUA EXT

SMART

2) A hard reset is issued or the power is turned off.

3) When ICRC (Interface CRC) Error has occurred.

6.4.3 Using the read segment buffer

Methods of using the read segment buffer are explained for following situations.

6.4.3.1 Miss-hit

In this situations, the top block of read requested data is not stored at all in the data buffer. As a result, all of the read requested data is read from disk media.

- 1) HAP (host address pointer) and DAP (disk address pointer) are defined in the head of the segment allocated from Buffer. (If pre-read is executed, HAP is set at the requested data reading position.)

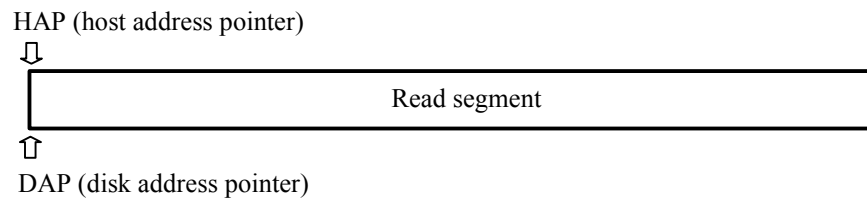

- 2) During reading of read requested data, the request data that has already been read is sent to the host system.

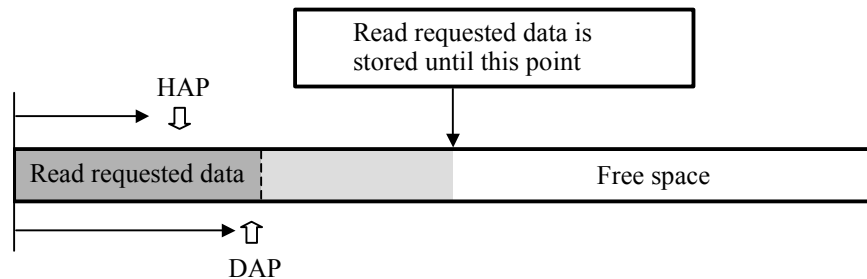

- 3) When reading of read requested data is completed and transfer of the read requested data to the host system is completed, reading of the disk continues until a certain amount of data is stored.

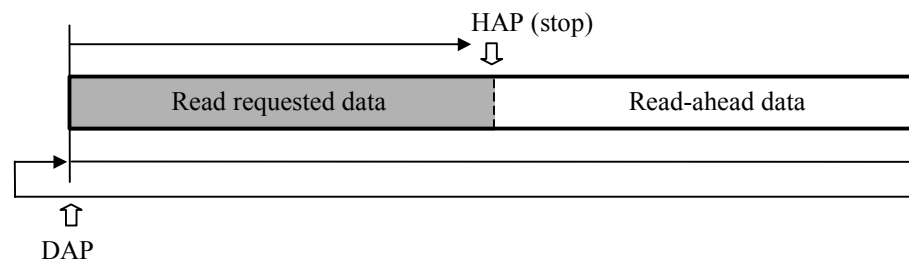

- 4) The following cache valid data is for the read command that is executed next:

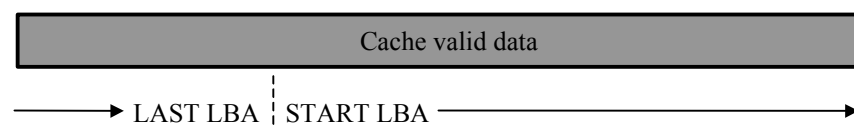

6.4.3.2 Sequential hit

When the read command that is targeted at a sequential address is received after execution of the read commands is completed, the read command transmits the Read requested data to the host system continuing read-ahead without newly allocating the buffer for read.

- 1) When the sequential read command is received, HAP is set in the sequential address of the last read command, and DAP is set at a present read position as it is.

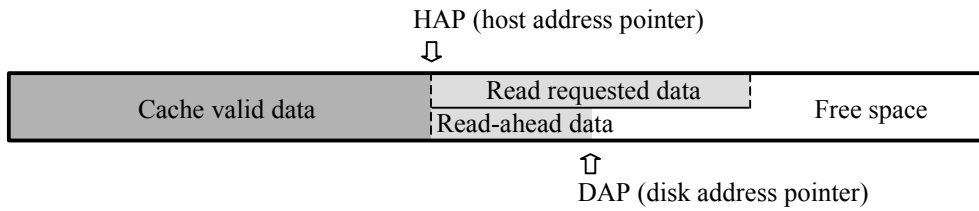

- 2) During reading of read requested data, the request data that has already been read is sent to the host system.

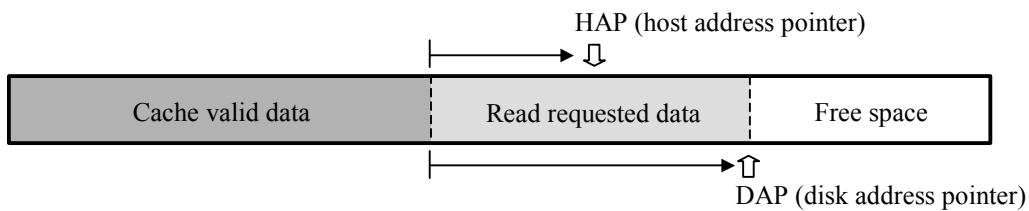

- 3) When reading of read requested data is completed and transfer of the read requested data to the host system is completed, the read-ahead operation continues until a certain amount of data is stored.

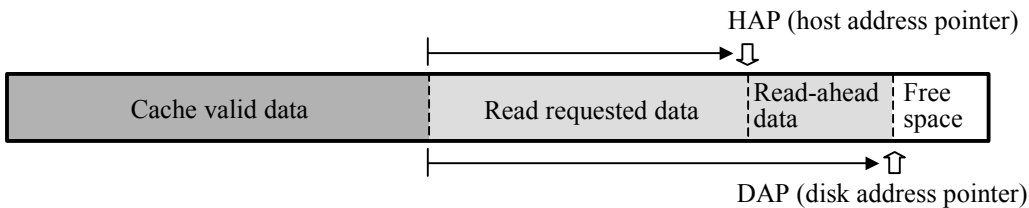

- 4) The following cache valid data is for the read command that is executed next:

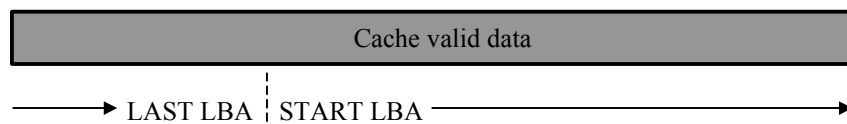

6.4.3.3 Full hit

In this situation, all read requested data is stored in the data buffer. Transfer of the read requested data is started from the location where hit data is stored. For data that is a target of caching and remains before a full hit, the data is retained when execution of the command is completed. This is done so that a new read-ahead operation is not performed. If the full hit command is received during the read-ahead operation, a transfer of the read requested data starts while the read-ahead operation is in progress.

- 1) An example is the state shown below where the previous read command is executing sequential reading. First, HAP is set at the location where hit data is stored.

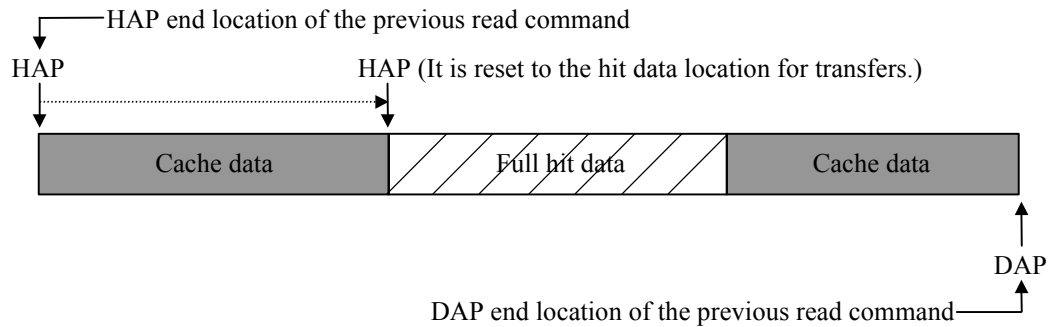

- 2) The read requested data is transferred, and a new read-ahead operation is not performed.

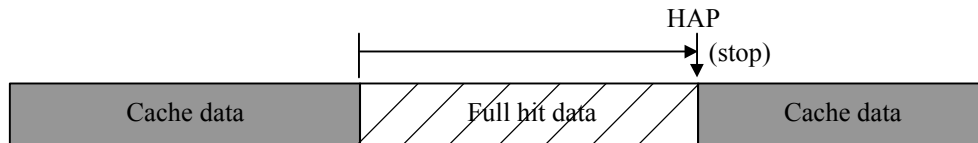

6.5 Write Cache

Write Cache is the function for reducing the command processing time by separating command control to disk media from write control to disk media. When Write Cache is permitted, the write command can keep receiving as long as the space available for data transfers remains free on the data buffer. Because of this function, command processing appears to be completed swiftly from the viewpoint of the host. It improves system throughput.

The disk drive has a drive-specific function. When the temperature becomes about -20°C or lower, the function disables the Write cache function, writes data into user areas, and automatically performs the data verify operation (Read check) for those areas. When writing data and verifying the area are completed during this operation, the busy state is canceled. (When the temperature is about -20°C or higher, the disk drive operates depending on whether the SET FEATURES command caching function is enabled or disabled, and only the normal write operation is performed.)

6.5.1 Cache operation

(1) Command that are targets of caching

The Commands that are targets of caching are as follows:

- WRITE SECTOR (S)
- WRITE MULTIPLE
- WRITE DMA
- WRITE SECTOR (S) EXT
- WRITE MULTIPLE EXT
- WRITE DMA EXT

However, the caching operation is not performed when the caching function is prohibited by the SET FEATURES command.

(2) Invalidation of cached data

If an error occurs during writing onto media, write processing is repeated up to as many times as specified for retry processing. If retry fails for a sector because the retry limit is reached, automatic alternate sector processing is executed for the sector. If the automatic alternate sector processing fails, the data in the sector for which automatic alternate sector processing failed is invalidated without being guaranteed.

If data remains in sectors following a sector for which automatic alternate sector processing failed, the data is invalidated without being guaranteed.

Moreover, when the command (clause 6.4.2(3)) is accepted and HOST CRC Error is generated, the caching data is invalidated.

<Exception>

- If a Reset or command is received while a transfer of one sector of data is in progress, data is not written in the sector of the media where the interruption occurred, and sectors accepted before interruption occurred is written in the medium.

(3) Status report in the event of an error

The status report concerning an error occurring during writing onto media is created when the next command is issued. Where the command reporting the error status is not executed, only the error status is reported. Only the status of an error that occurs during write processing is reported.

<Exceptions>

The error status is not reported in the following case:

- The reset command is received after an error has occurred during writing to media.
- Reset processing is performed as usual. The error status that has occurred during writing to media is not reported.

(4) Enabling and disabling

Enabling and disabling of the Write Cache function can be set only with the SET FEATURES command. The setting does not changed even when the error status is reported.

The initial setting is stored in the system area of media. System area information is loaded whenever the power is turned on.

(5) Reset response

When a reset is received while cached data is stored on the data buffer, data of the data buffer is written on the media, and reset processing is then performed. This is true for both a hard reset and soft reset.

(6) Caching function when power supply is turned on.

The caching function is invalid until Calibration is done after the power supply is turned on (about 7 or 8 sec). It is effective in Default after that as long as the caching function is not invalidly set by the SET FEATURES command.

IMPORTANT

If Write Cache is enabled, there is a possibility that data transferred from the host with the Write Cache enable command is not completely written on disk media before the normal end interrupt is issued.

If an unrecoverable error occurs while multiple commands that are targets of write caching are received, the host has difficulty determining which command caused the error. (An error report is not issued to the host if automatic alternating processing for the error is performed normally.) Therefore, the host cannot execute a retry for the unrecoverable error while Write Cache is enabled. Be very careful on this point when using this function.

If a write error occurs, an abort response is sent to all subsequent commands.

Glossary

Actuator

Head positioning assembly. The actuator consists of a voice coil motor and head arm. It positions the read-write (R-W) head.

AT bus

A bus between the host CPU and adapter board

ATA (AT Attachment) standard

The ATA standard is for a PC AT interface regulated to establish compatibility between products manufactured by different vendors. Interfaces based on this standard are called ATA interfaces.

CHS addressing for drives

The CHS addressing collectively refers to the parameters defined by BIOS of the host system, which, for example, include the number of cylinders, the number of heads, and the number of sectors per track in the drive. The physical specifications of the drive do not always correspond to these parameters.

The CHS addressing cannot make full use of the physical storage area of these drives. To make the best use of these drives, the use of LBA addressing is required.

Command

Commands are instructions to input data to and output data from a drive. Commands are written in command registers.

Data block

A data block is the unit used to transfer data. A data block normally indicates a single sector.

DE

Disk enclosure. The DE includes the disks, built-in spindle motor, actuator, heads, and air filter. The DE is sealed to protect these components from dust.

Master (Device 0)

The master is the first drive that can operate on the AT bus. The master is daisy-chained with the second drive which can operate in conformity with the ATA standard.

MTBF

Mean time between failures. The MTBF is calculated by dividing the total operation time (total power-on time) by the number of failures in the disk drive during operation.

MTTR

Mean time to repair. The MTTR is the average time required for a service person to diagnose and repair a faulty drive.

PIO (Programmed input-output)

Mode to transfer data under control of the host CPU

Positioning

Sum of the seek time and mean rotational delay

Power save mode

The power save modes are idle mode, standby mode, and sleep mode.

In idle mode, the drive is neither reading, writing, nor seeking data. In standby mode, the spindle motor is stopped and circuits other than the interface control circuit are sleeping. The drive enters sleep mode when the host issues the SLEEP command.

Reserved

Reserved bits, bytes, and fields are set to zero and unusable because they are reserved for future standards.

Rotational delay

Time delay due to disk rotation. The mean delay is the time required for half a disk rotation. The mean delay is the average time required for a head to reach a sector after the head is positioned on a track.

Seek time

The seek time is the time required for a head to move from the current track to another track. The seek time does not include the mean rotational delay.

Slave (Device 1)

The slave is a second drive that can operate on the AT bus. The slave is daisy-chained with the first drive operating in conformity with the ATA standard.

Status

The status is a piece of one-byte information posted from the drive to the host when command execution is ended. The status indicates the command termination state.

VCM

Voice coil motor. The voice coil motor is excited by one or more magnets. In this drive, the VCM is used to position the heads accurately and quickly.

This page is intentionally left blank.

Acronyms and Abbreviations

A		I	
ABRT	Aborted command	IDNF	ID not found
AIC	Automatic idle control	IRQ14	Interrupt request 14
AMNF	Address mark not found		
ATA	AT attachment	L	
AWG	American wire gage	LED	Light emitting diode
B		M	
BBK	Bad block detected	MB	Mega-byte
BIOS	Basic input-output system	MB/S	Mega-byte per seconds
		MPU	Micro processor unit
C		P	
CORR	Corrected data	PCA	Printed circuit assembly
CH	Cylinder high register	PIO	Programmed input-output
CL	Cylinder low register		
CM	Command register	R	
CSR	Current sense resistor	RLL	Run-length-limited
CSS	Current start/stop	RoHS	The Restrictions of the use of certain Hazardous Substances in electrical and electronic equipment
CY	Cylinder register		
D		S	
dB A	dB A-scale weighting	SA	System area
DE	Disk enclosure	SC	Sector count register
DH	Device/head register	SG	Signal ground
DRDY	Drive ready	SN	Sector number register
DRQ	Data request bit	ST	Status register
DSC	Drive seek complete		
DWF	Drive write fault	T	
E		TPI	Track per inches
ECC	Error checking and correction	TRONF	Track 0 not found
ER	Error register	Typ	Typical
ERR	Error		
EU	European Union	U	
F		UNC	Uncorrectable ECC error
FR	Feature register		
H		V	
HA	Host adapter	VCM	Voice coil motor
HDD	Hard disk drive		

This page is intentionally left blank.

Index

1 drive connection 2-3
2 drives configuration 2-4
2 drives connection 2-4
2MB buffer 6-12

A

A/D converter circuit 4-11
AAM 5-92
acceleration mode 4-19
acoustic noise 1-11
acoustic noise specification 1-11
active idle mode 6-7
active mode 6-7
actuator 2-2, 4-2
actuator motor control 4-18
adaptability 1-2
advanced power management 1-14,
1-15, 5-91
AGC circuit 4-10
air circulation system 2-2
air filter 4-3
alternate status register 5-13
alternating processing
for defective sector 6-10
ambient temperature 3-5
APM 1-14, 5-91
ATA interface 2-3
attribute ID 5-47
attribute value for the worst case so
far 5-48
automatic acoustic management 5-92
automatic alternating processing 6-11
average positioning time 1-2

B

blower 4-3
burst even1 4-17
burst even2 4-17
burst odd 4-17

C

cable connection 3-8, 3-9
cable connector specification 3-9
cache operation 6-18

caching function when power supply
is turned on 6-19
caching operation 6-13
CHECK POWER MODE 5-39, 6-9
CHECK POWER MODE command 6-8
check sum 5-51, 5-54, 5-55
circuit configuration 4-3, 4-5
command block register 5-8
command code and parameter 5-14, 5-15,
5-16, 5-127, 5-128
command data structure 5-54
command description 5-18
command processing during self-
calibration 4-8
command protocol 5-129
command register 5-13
command that are targets of caching 6-18
command without data transfer 5-134
command, target of caching 6-13
compact 1-2
compensating open loop gain 4-7
connection to ATA interface 1-3
contents of security password 5-101
contents of SECURITY SET
PASSWORD data 5-93
control block register 5-13
controller circuit 2-3, 4-4
CSEL setting 3-12
current and power dissipation 1-9
current attribute value 5-48
current fluctuation (Typ.) at +5 V
when power is turned on 1-10
current LBA under test 5-56
current requirements and power
dissipation 1-9
current span under test 5-56
cylinder high register 5-10
cylinder low register 5-10

D

D/A converter (DAC) 4-13
data area 4-15
data assurance in the event of power
failure 1-12
data buffer 1-3

- DATA buffer structure 6-12
data format of SMART
 comprehensive error log 5-54
data format of SMART summary
 error log 5-53
data format version number 5-47
data register 5-8
data transfer mode 5-90
data, target of caching 6-13
data-surface servo format 4-15
default function 5-34
defect processing 6-9
description 5-110, 5-111, 5-112,
 5-113, 5-114, 5-116, 5-117, 5-118,
 5-120, 5-121, 5-122, 5-124, 5-125,
 5-126
device configuration 2-1, 2-2
DEVICE CONFIGURATION 5-58
 FREEZE LOCK 5-59
 IDENTIFY 5-59
 IDENTIFY data structure 5-61, 5-62
 RESTORE 5-59
DEVICE CONFIGURATION SET 5-59
device connection 3-9
device connector 3-8
device control register 5-14
device overview 1-1
device pausing ultra DMA data
 out burst 5-161
device response to reset 6-2
device specification 1-4
device terminating ultra DMA data
 in burst 5-157
 out burst 5-163
device/head register 5-11
diagnostic code 5-28
digital PLL circuit 4-11
dimension 3-2
disk 2-2, 4-2
disk drive outer view 2-2
DMA data transfer command 5-135
DOWNLOAD MICROCODE 5-31
driver circuit 4-14
- E**
- enabling and disabling, write cache 6-19
environmental protection 1-2
environmental specification 1-10
error correction and retry by ECC 1-3
error data structure 5-54
error logging capability 5-51
error posting 5-127
- error rate 1-13
error register 5-8
error reporting condition 5-112, 5-118,
 5-126
example of model name and product
 number 1-6
EXECUTE DEVICE DIAGNOSTIC 5-28
execution example of READ
 MULTIPLE command 5-63
execution timing of self-calibration 4-8
- F**
- factory default setting 3-11
failure prediction capability flag 5-50
feature 1-2
feature flag 5-57
feature register 5-9
feature register value (subcommand)
 and function 5-43
feature register value and settable
 mode 5-89
features register values
 (subcommands) and function 5-42, 5-44
FIR circuit 4-11
FLUSH CACHE 5-74
FLUSH CACHE EXT 5-126
format of device attribute value data 5-46
format of insurance failure threshold
 value data 5-46
FR = 01h 5-105
FR = 02h 5-106
FR = 03h 5-107
FR = 04h 5-108
FR = C0h 5-59
FR = C1h 5-59
FR = C2h 5-59
FR = C3h 5-59
frame 3-3
frequency characteristic of
 programmable filter 4-10
full hit 6-17
function and performance 1-2
- G**
- gray code 4-17
- H**
- handling caution 3-6, 3-7
head 2-2
high resistance against shock 1-3
high-speed transfer rate 1-2

-
- host command 5-14
 - host pausing ultra DMA data
 - in burst 5-156
 - host terminating ultra DMA data
 - in burst 5-158
 - out burst 5-162
- I**
- I/O register 5-7
 - IDENTIFY DEVICE 5-76
 - IDENTIFY DEVICE DMA 5-77
 - IDLE 5-37, 6-9
 - IDLE IMMEDIATE 5-34, 6-9
 - Information to be read by IDENTIFY
 - DEVICE command 5-78, 5-79
 - INITIALIZE DEVICE
 - PARAMETERS 5-30
 - PARAMETERS command 6-8
 - initiating ultra DMA data
 - in burst 5-138, 5-151
 - out burst 5-143, 5-159
 - inner guard band 4-15
 - input voltage 1-7
 - installation condition 3-1
 - insurance failure threshold 5-51
 - interface 1-3, 5-1
 - interface signal 5-2
 - invalidating caching-target data 6-13
 - invalidation of cached data 6-18
- J**
- jumper location 3-10
 - jumper setting 3-10
 - jumper setting of master or slave
 - drive 3-11
- L**
- large capacity 1-2
 - limitation of mounting 3-3
 - load/unload function 1-13
 - location of breather 3-4
 - location of setting jumper 3-10
 - log directory data format 5-51
 - logical Interface 5-6
 - low noise and vibration 1-3
 - low power idle mode 6-7
- M**
- master drive-slave drive setting 3-11
 - master/slave 1-3
 - mean time between failure (MTBF) 1-12
 - mean time to repair (MTTR) 1-12
 - media defect 1-13
 - microprocessor unit (MPU) 4-13
 - miss-hit 6-15
 - model and product number 1-6
 - mounting 3-3
 - mounting frame structure 3-3
 - multiword data transfer 5-150
 - multiword DMA data transfer timing 5-150
- N**
- normal DMA data transfer 5-136
- O**
- off-line data collection capability 5-50
 - off-line data collection status 5-48, 5-49
 - operation 6-1
 - operation of DOWNLOAD
 - MICROCODE 5-32
 - operation to move head to reference
 - cylinder 4-18
 - orientation 3-3
 - other command 5-135
 - outer guard band 4-15
 - outline 4-2
 - overview 5-137
- P**
- PAD 4-17
 - pausing ultra DMA data
 - out burst 5-144
 - pausing Ultra DMA data
 - in burst 5-139
 - phases of operation 5-138
 - physical interface 5-2
 - physical sector servo configuration
 - on disk surface 4-16
 - PIO data transfer 5-149
 - PIO data transfer timing 5-149
 - PIO data transferring command from
 - device to host 5-129
 - host to device 5-132
 - positioning error 1-13
 - post code 4-17
 - power amplifier 4-13
 - power command 6-9
 - power requirement 1-7
 - power save 6-7
 - power save mode 1-2, 6-7
 - power supply configuration 4-4
-

- power supply connector (CN1) 3-10
power up in standby setting 3-13
power-on and reset 5-164
power-on sequence 4-6
programmable filter circuit 4-10
protocol for command abort 5-131
protocol for the command execution
 without data transfer 5-135
- R**
- raw attribute value 5-48
READ BUFFER 5-73
read circuit 4-10
READ DMA 5-69
READ DMA (EXT) 6-12
READ DMA EXT 5-111
READ DMA EXT 6-12
READ LOG EXT 5-114
READ MULTIPLE 5-63
READ MULTIPLE (EXT) 6-12
READ MULTIPLE EXT 5-113, 6-12
READ NATIVE MAX ADDRESS 5-103
READ NATIVE MAX ADDRESS
 EXT 5-112
READ SECTOR(S) 5-21
READ SECTOR(S) (EXT) 6-12
READ SECTOR(S) COMMAND
 protocol 5-130
READ SECTOR(S) EXT 5-110, 6-12
READ VERIFY SECTOR(S) 5-26
READ VERIFY SECTOR(S) EXT 5-124
read/write circuit 2-3, 4-3, 4-9
read/write circuit block diagram 4-9
read/write preamplifier (PreAMP) 4-9
read-ahead cache 6-12
read-ahead cache system 1-3
RECALIBRATE 5-20
recommended power-off sequence 1-14
recommended series termination for
 ultra DMA 5-148
reliability 1-12
reset 6-8
reset response 6-19
response to
 diagnostic command 6-6
 hardware reset 6-3, 6-4
 power-on 6-2, 6-3
 software reset 6-5
ripple 1-7
- S**
- sector count register 5-9
sector number register 5-10
sector slip processing 6-10
SECURITY DISABLE PASSWORD 5-101
SECURITY ERASE PREPARE 5-97
SECURITY ERASE UNIT 5-98
SECURITY FREEZE LOCK 5-99
SECURITY SET PASSWORD 5-93
SECURITY UNLOCK 5-95
SEEK 5-27
seek operation 4-18
selective self-test feature flag 5-57
selective self-test log data structure 5-56
selective self-test pending time 5-57
self-calibration 4-7
self-calibration content 4-7
self-diagnosis 1-3
self-test execution status 5-49, 5-55
self-test index 5-55
self-test number 5-55
sensing and compensating for
 external force 4-7
sequential hit 6-16
series termination required for ultra
 DMA 5-148
service area 3-6
service life 1-12
servo burst capture circuit 4-13
servo circuit 4-3
servo control 4-12
servo control circuit 4-12
servo frame format 4-17
servo mark 4-17
SET FEATURES 5-89, 6-9
SET MAX 5-104
SET MAX ADDRESS 5-104
SET MAX ADDRESS EXT 5-118
SET MAX FREEZE LOCK 5-108
SET MAX LOCK 5-106
SET MAX SET PASSWORD 5-105
SET MAX UNLOCK 5-107
SET MULTIPLE MODE 5-67
shock and vibration 1-11
shock and vibration specification 1-11
signal assignment on the connector 5-3
SLEEP 5-40, 6-9
sleep mode 6-8
slope of an input voltage at rise 1-7
SMART 5-41
SMART error logging 5-52
SMART self-test 5-55
SMART self-test log data format 5-55
spare area 6-9
specification 1-5

specification summary	1-4
spindle	4-2
spindle motor.....	2-2
spindle motor control	4-19
spindle motor control circuit	4-13
spindle motor driver circuit.....	4-3
stable rotation mode	4-19
STANDBY	5-36, 6-9
STANDBY command.....	6-8
STANDBY IMMEDIATE	5-33, 6-9
STANDBY IMMEDIATE command	6-8
standby mode	6-8
start mode.....	4-19
status	5-54
status flag	5-48
status register.....	5-11
status report in event of error	6-19
subassembly	4-2
surface temperature measurement point.....	3-5
sustained ultra DMA data in burst.....	5-155
sustained Ultra DMA data out burst.....	5-160
system configuration	2-3

T

terminating ultra DMA data in burst.....	5-140
out burst.....	5-145
test span.....	5-56
the data in transfer.....	5-139
out transfer.....	5-144
theory of device operation.....	4-1
timing	5-149
total number of drive error	5-54
track following operation	4-18
track slip processing.....	6-10

U

ultra DMA CRC rule	5-147
ultra DMA data in command.....	5-138
out command.....	5-143
ultra DMA data burst timing requirement	5-152
ultra DMA data transfer.....	5-151
ultra DMA feature set.....	5-137
ultra DMA sender and recipient timing requirement.....	5-154
ultra DMA termination with pull-up or pull-down.....	5-148
unload feature	5-34
UNLOAD IMMEDIATE	5-34
unrecoverable read error.....	1-13
using read segment buffer	6-15

V

VCM current sense resistor (CSR)	4-14
viterbi detection circuit.....	4-11

W

wide temperature range	1-2
WRITE BUFFER	5-75
write cache.....	1-4, 6-18
write circuit.....	4-9
WRITE DMA	5-71
WRITE DMA EXT	5-117
WRITE DMA FUA EXT	5-121
WRITE LOG EXT	5-122
WRITE MULTIPLE.....	5-65
WRITE MULTIPLE EXT	5-120
WRITE MULTIPLE FUA EXT	5-125
write precompensation.....	4-9
WRITE SECTOR(S)	5-23
WRITE SECTOR(S) command protocol.....	5-133
WRITE SECTOR(S) EXT	5-116
WRITE VERIFY	5-25
write/read recovery	4-17

This page is intentionally left blank.

Comment Form

We would appreciate your comments and suggestions regarding this manual.

Manual code	C141-E258-03EN		
Manual name	MHW2060AC, MHW2040AC DISK DRIVES PRODUCT MANUAL		
Please mark each item: E(Excellent), G(Good), F(Fair), P(Poor).			
General appearance	()	Illustration	()
Technical level	()	Glossary	()
Organization	()	Acronyms & Abbreviations	()
Clarity	()	Index	()
Accuracy	()		
Comments & Suggestions			

List any errors or suggestions for improvement.

Page	Line	Contents

Please send this form to the address below. We will use your comments in planning future editions.

Address: Fujitsu Learning Media Limited
37-10 Nishikamata 7-chome
Oota-ku
Tokyo 144-0051
JAPAN

Fax: 81-3-3730-3702

Organization: _____

Name: _____

This page is intentionally left blank.

**MHW2060AC, MHW2040AC DISK DRIVES
PRODUCT MANUAL**

C141-E258-03EN

**MHW2060AC, MHW2040AC DISK DRIVES
PRODUCT MANUAL**

C141-E258-03EN

FUJITSU